

ERAVANT

NEXT GENERATION MILLIMETERWAVE COMPONENTS

F BAND UPDATES

February 2021

TABLE OF CONTENTS

3 [Introduction](#)

5 [Antennas: OMT, Polarizer, Rectangular Horns, and Conical Horns](#)

10 [Amplifiers: Power and Low Noise](#)

13 [Frequency Multipliers: Active and Passive](#)

14 [Frequency Converters: Balanced Mixers, I/Q Mixers and Harmonic Mixers](#)

22 [Detectors](#)

24 [Passive Components: Diplexer, Waveguide to Coax Adapters, Power Dividers, Couplers and Filters](#)

27 [Waveguides: Straight, Bend and Twist](#)

28 [Ferrites: Faraday Isolator](#)

30 [Full Band Test Equipment: Extenders and High ENR Noise Source](#)

40 [Website](#)

INTRODUCTION

ERAVANT designs and manufactures total solutions for microwave and millimeterwave applications covering 10 MHz to 220 GHz and up to 325 GHz.

- **This presentation introduces Eravant's selective standard product offerings in the F-Band (90 to 140 GHz).**
- Our full product offering, including Limited Run models, are listed on our website at www.eravant.com.

Additional products and presentations are available upon customer request:

- Custom models for components and subassemblies can be configured to customers' specifications.
- Presentations about Ka, Q, U, V, E, W, D and G-Bands are available.
- Presentations for specific applications like 5G/IoT, Space, Test Instrumentation, Communications, and Radar are also available **online**.

ERAVANT PRODUCT COVERAGE

- ERAVANT offers Total Product Solutions to configure any system applications in the Frequency Range of DC to 220 GHz and up to 325 GHz.
- F Band products are mainly used in
 - THz communication systems
 - Automotive Radar systems
 - 5G systems
 - Scientific and industrial systems
 - Test equipment and set ups
- The intent of this presentation is to present the ERAVANT product offerings in **F Band** to help the customers having a quick overview of available product families for their project and system planning. The model selected is for illustration purpose only. The full product offerings under many models with various performance in the same product family are available on **Eravant's website.**

Rectangular Horn Antenna

Model SAR-2309-08-S2

Parameter	Minimum	Typical	Maximum
Frequency	90 GHz		140 GHz
Gain	21 dBi	23 dBi	24 dBi
Polarization		Linear	
3 dB Beamwidth, E-Plane		11°	
3 dB Beamwidth, H-Plane		12°	
Sidelobes, E-Plane		-14 dB	
Sidelobes, H-Plane		-30 dB	
Return Loss		23 dBi	



Typical Antenna Pattern @ 115 GHz

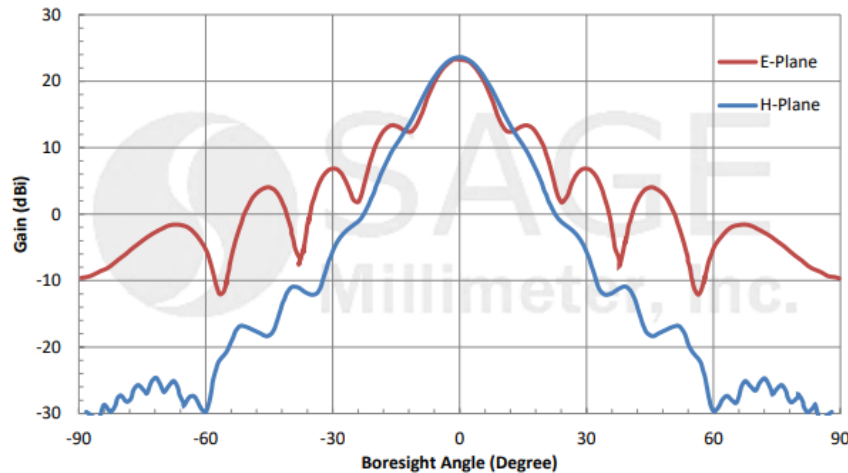

Typical Gain vs. Frequency

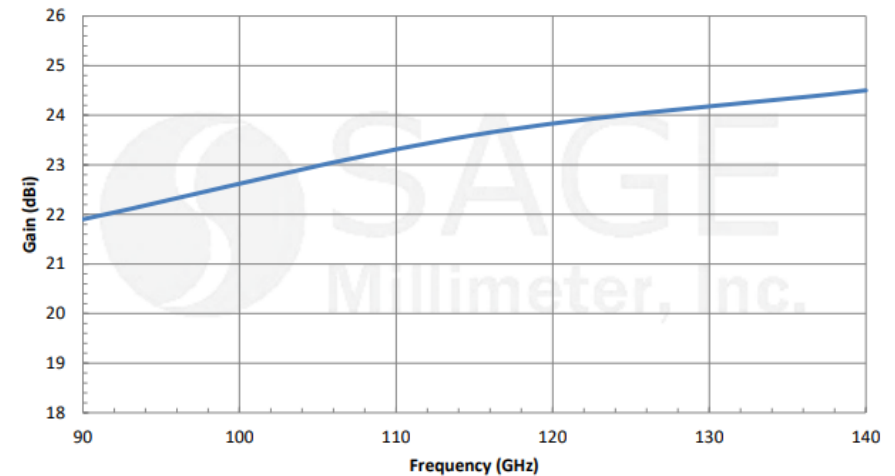

Conical Horn Antenna

Model SAC-1533-082-S2

Parameter	Minimum	Typical	Maximum
Frequency*	110 GHz		112 GHz
Gain		15 dBi	
3 dB Beamwidth, E-plane		30°	
3 dB Beamwidth, H-plane		36°	
Sidelobes, E-plane		-16 dB	
Sidelobes, H-plane		-28 dB	
Return Loss		23 dB	



*Note: Can operate from 95 to 140 GHz if the dominant mode is maintained.

Typical Antenna Pattern @ 106 GHz

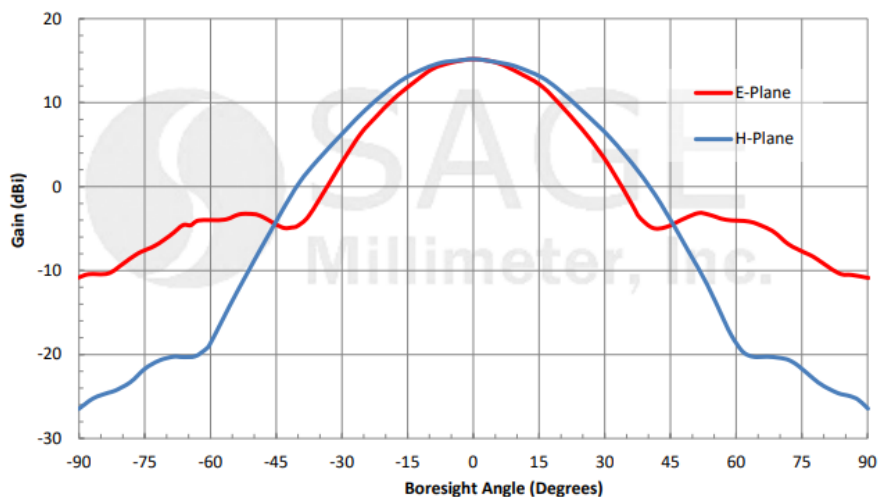

Typical Gain vs. Frequency

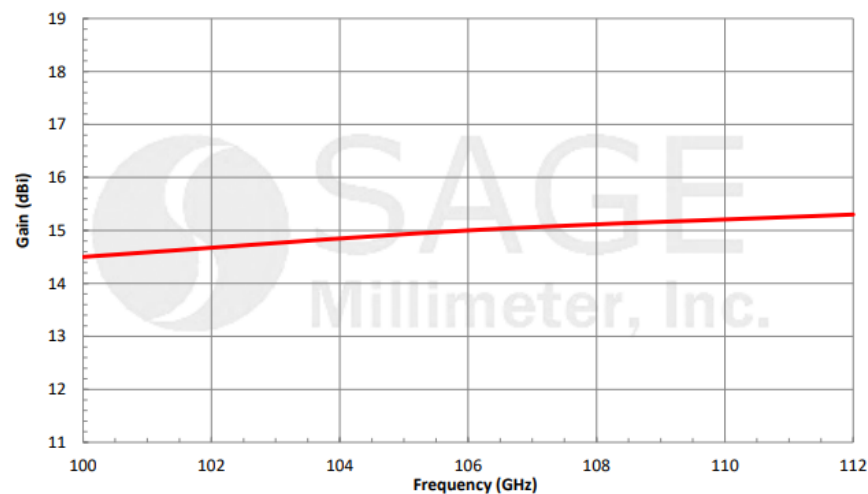

Dual Polarized Antenna, 90 to 140 GHz

Model SAF-9031441335-094-S1-080-DP

Parameter	Minimum	Typical	Maximum
Frequency	90 GHz	115 GHz	140 GHz
Gain		13 dBi	
3 dB Beamwidth, E-plane		40°	
3 dB Beamwidth, H-plane		40°	
Sidelobe Levels		-25 dB	
V and H Port Isolation		30 dB	
RF Connector	WR-08 with UG-387/U-M Flange		
Weight		0.1 lbs	



Simulated Antenna Patterns @ 115 GHz

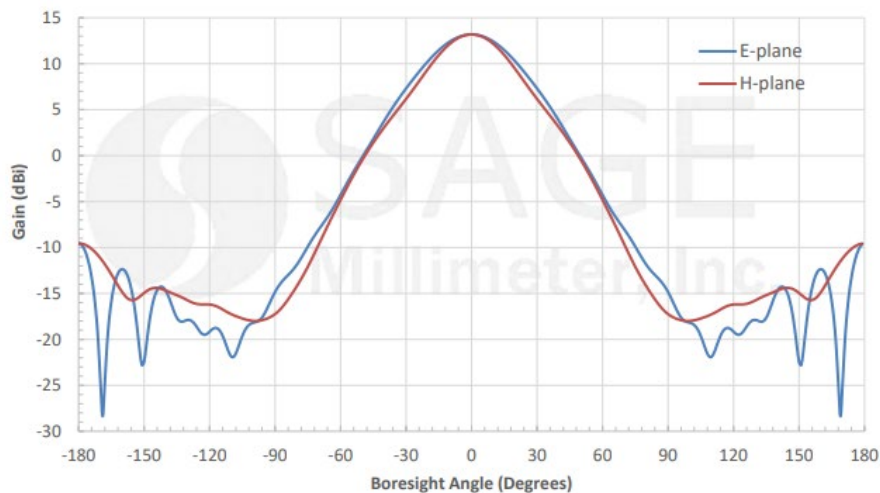

Simulated Gain vs. Frequency

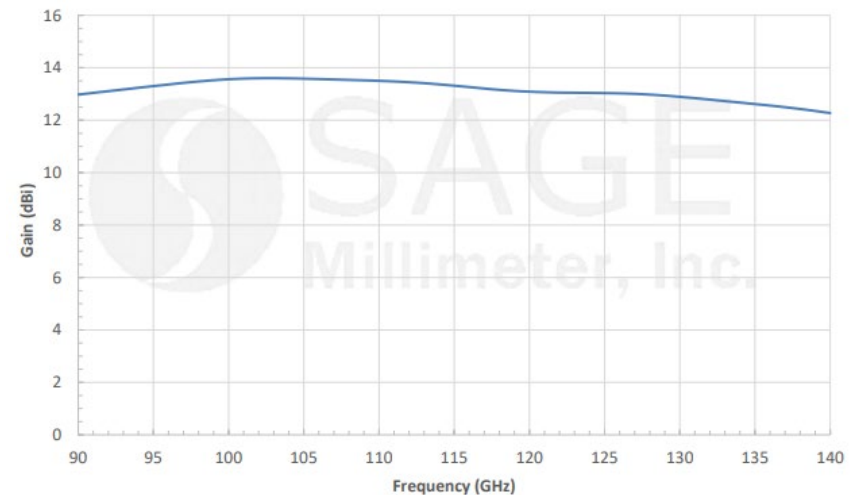

Full Band Orthomode Transducer

Model SAT-FF-08008-S1

Parameter	Minimum	Typical	Maximum
Frequency	90 GHz		140 GHz
Insertion Loss, Vertical		2.0 dB	
Insertion Loss, Horizontal		2.5 dB	
Isolation		30 dB	
Cross Polarization		20 dB	



Mechanical Outline: (Unless otherwise specified, all dimensions are in inches [millimeters])

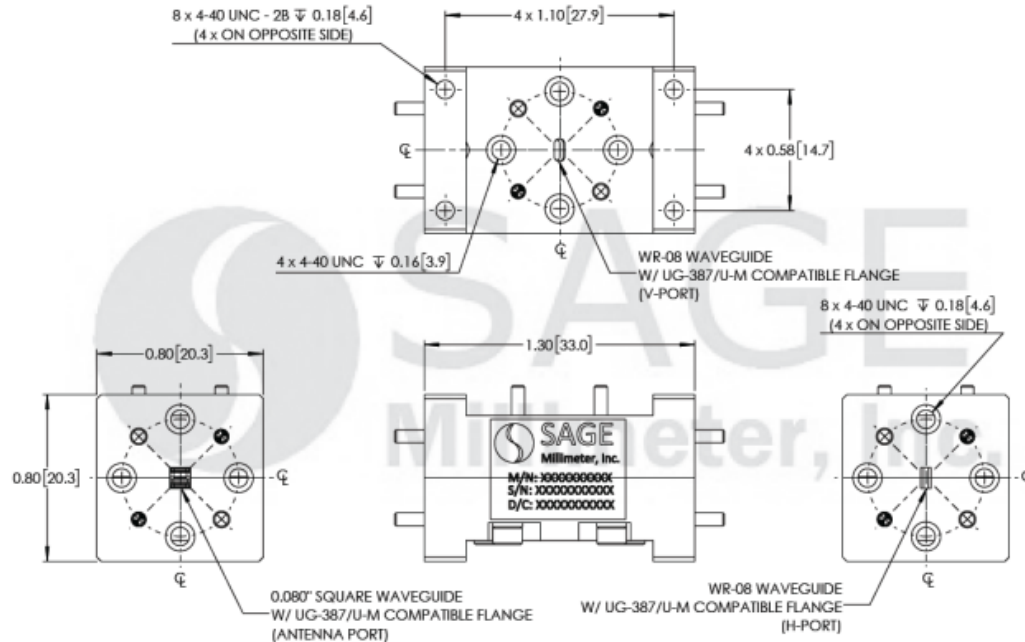

Features

- High Isolation
- Low Insertion Loss
- Full Band Coverage
- 20 dB Cross-pol Rejection

Narrow Band Orthomode Transducer

Model SAT-114-07508-C1

Parameter	Minimum	Typical	Maximum
Frequency	110 GHz		118 GHz
Insertion Loss, Vertical		1.0 dB	
Insertion Loss, Horizontal		1.2 dB	
Isolation		30 dB	
Cross Polarization		20 dB	



Typical Performance vs. Frequency

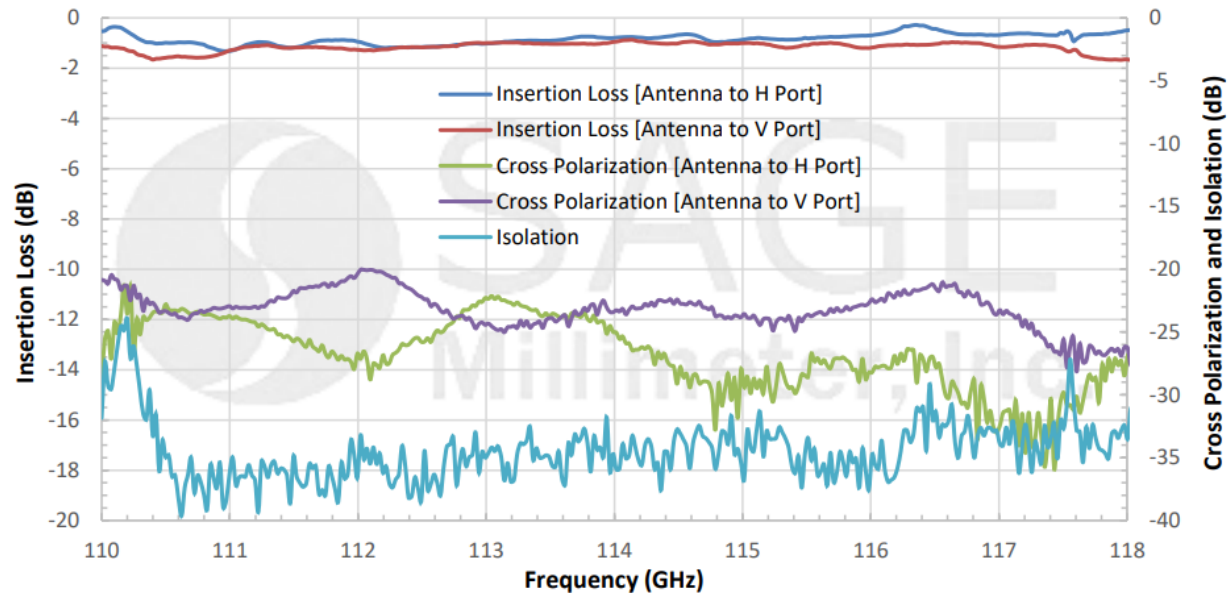

Features

- High Isolation
- Low Insertion Loss
- Circular Antenna Port
- 25 dB Cross-pol Rejection

Linear to Circular Polarizer

Model SAS-124-07506-F1

Parameter	Minimum	Typical	Maximum
Frequency	114 GHz		128 GHz
Insertion Loss, Vertical		2.5 dB	
Insertion Loss, Horizontal		2.5 dB	
Isolation		30 dB	
Cross Polarization		18 dB	



Typical Performance vs. Frequency

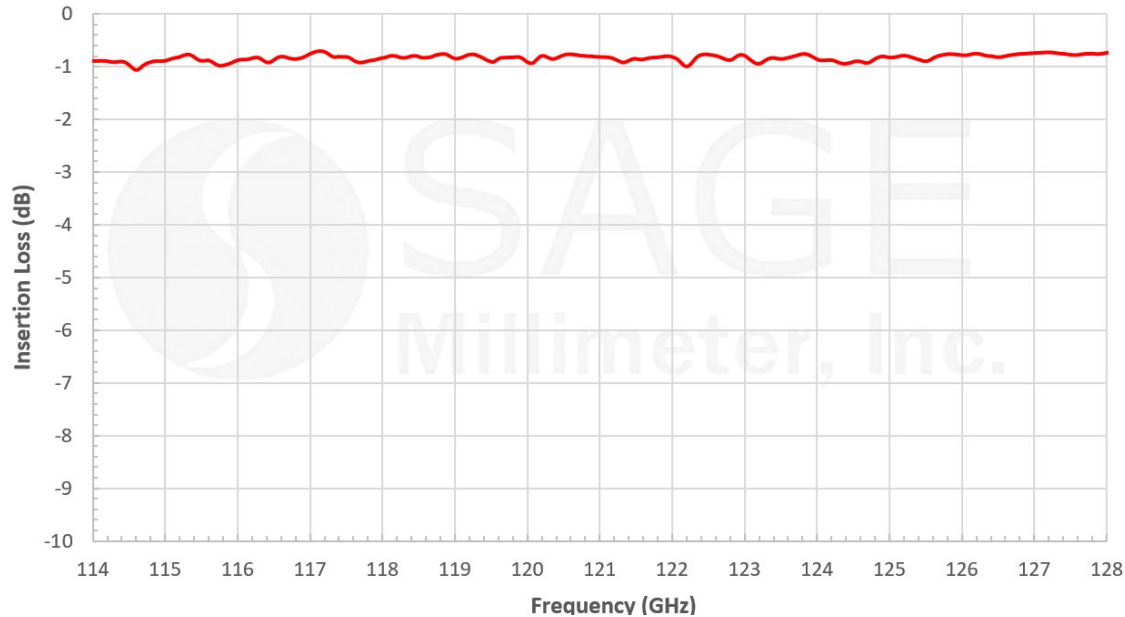

Features

- Good Axial Ratio
- Low Insertion Loss
- Broad Band Coverage

Low Noise Amplifier, 95 to 145 GHz

Model SBL-9531441565-0808-E1

Parameter	Minimum	Typical	Maximum
Frequency	95 GHz		145 GHz
Gain		15 dB	
Noise Figure		6.5 dB	
P_{in}			+10 dBm
Input Return Loss		10 dB	
Output Return Loss		10 dB	
DC Voltage	+6 V _{DC}	+8 V _{DC}	+12 V _{DC}
DC Supply Current		40 mA	

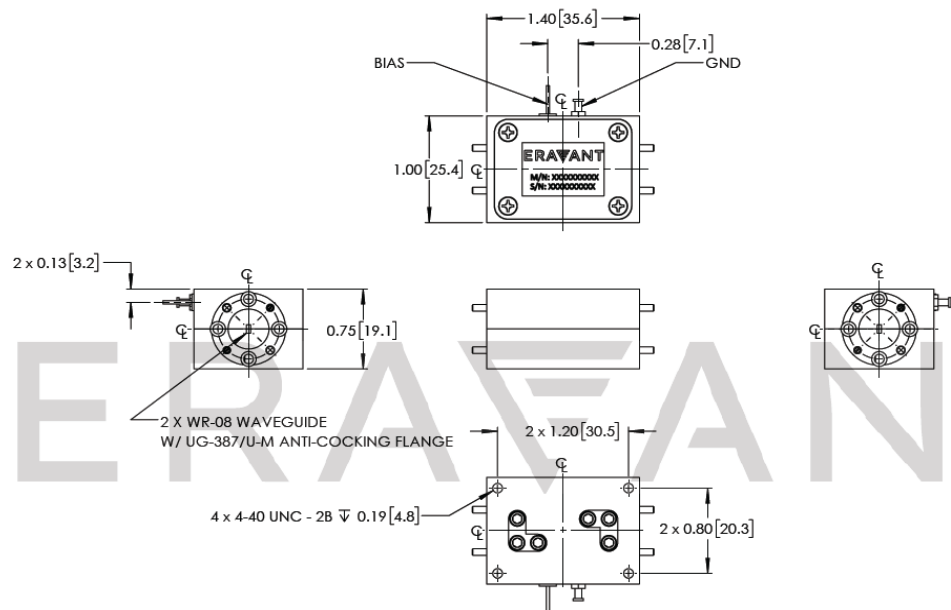

Low Noise Amplifier, 95 to 145 GHz

Model SBL-9531443565-0808-E1

Parameter	Minimum	Typical	Maximum
Frequency	95 GHz		145 GHz
Gain		35 dB	
Noise Figure		6.5 dB	
P_{in}			+10 dBm
Input Return Loss		10 dB	
Output Return Loss		10 dB	
DC Voltage	+6 V _{DC}	+8 V _{DC}	+12 V _{DC}
DC Supply Current		80 mA	

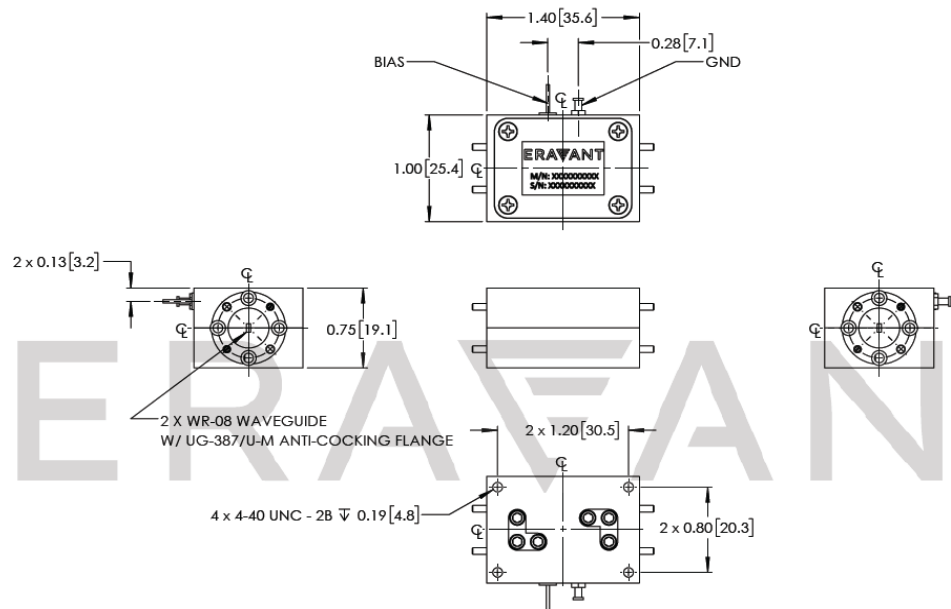

X2 Passive Multiplier

Model SFP-08215-S2

Parameter	Minimum	Typical	Maximum
Input Frequency	45 GHz		70 GHz
Output Frequency	90 GHz		140 GHz
Input Power		+16 dBm	+18 dBm
Output Power		+0 dBm	
Harmonic Suppression		20 dB	



Output Power vs. Frequency

Input Power: +16 dBm

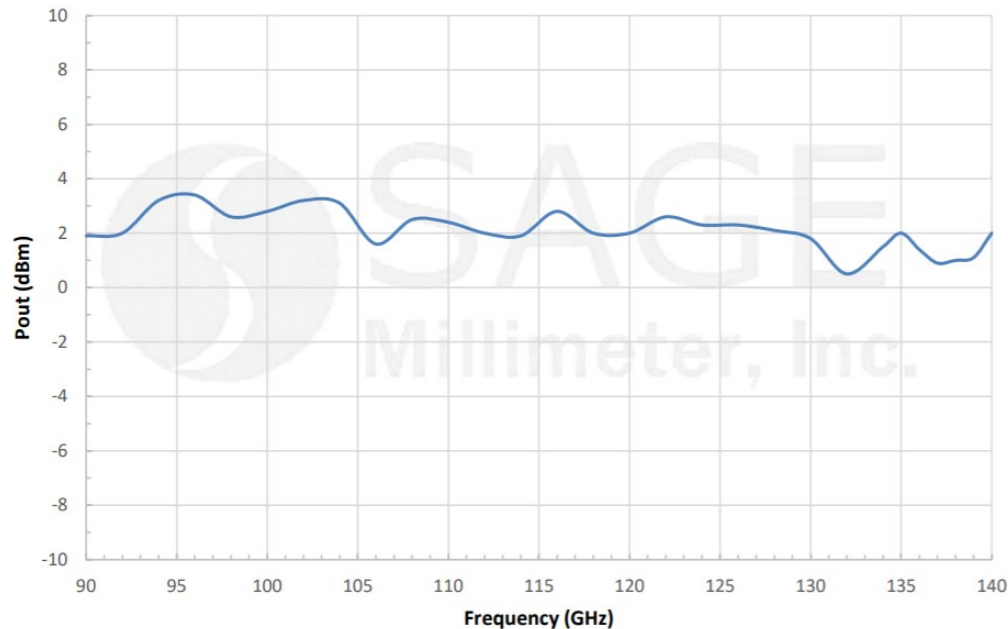

Features

- Minimal Conversion Loss
- No External Bias
- Compact Package

Balanced Mixer

Model SFB-08-N1

Parameter	Minimum	Typical	Maximum
RF Frequency	90 GHz		140 GHz
LO Frequency	90 GHz		140 GHz
IF Frequency	DC		40 GHz
LO Pumping Power		+13 dBm	+17 dBm
Conversion Loss		12 dB	15 dB
Input P _{1dB}		-3 dBm	
RF to LO Isolation		30 dB	
Combined RF and LO Power			+20 dBm

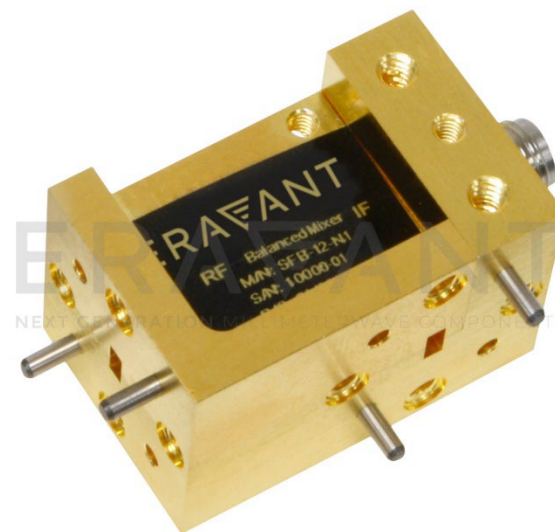

Typical Conversion Loss vs. Frequency

RF: -20 dBm; LO: 115 GHz/+12 dBm

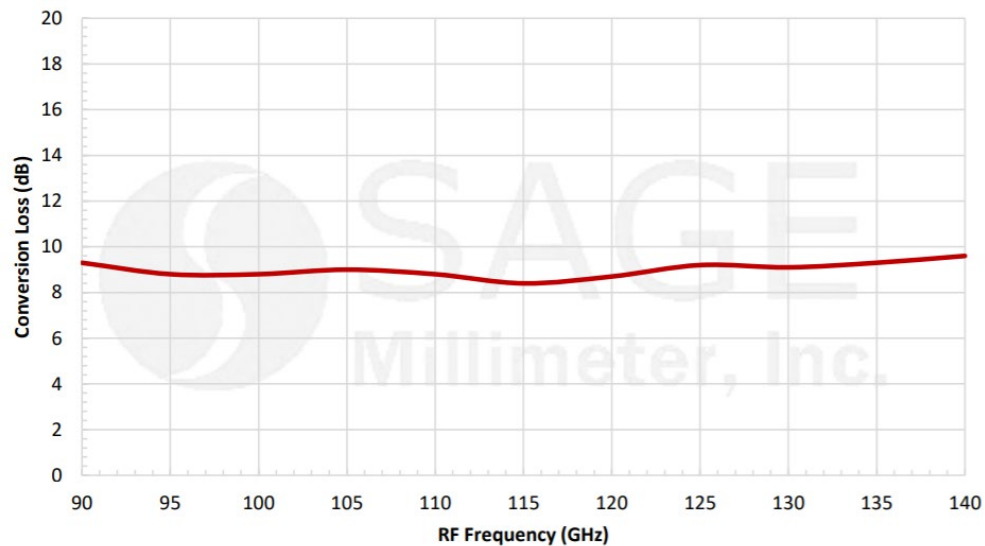

Features

- Full Waveguide Band Coverage
- Low Conversion Loss
- High IF Frequency up to 40 GHz and Beyond
- Compact Package

Externally Biased Balanced Mixer

Model SFB-08-E2

Parameter	Minimum	Typical	Maximum
RF Frequency Range	90 GHz		110 GHz
LO Frequency Range	90 GHz		110 GHz
IF Frequency Range	DC		40 GHz
Required LO Pumping Power	+0 dBm	+3 dBm	+10 dBm
Conversion Loss		13 dB	
Input P-1 dB		-10 dBm	
Combined RF and LO Power			+13 dBm
External Bias Voltage		+5 V _{DC} /2mA	+5 V _{DC} /5mA



Features

- Full Waveguide Band Coverage
- Low Conversion Loss
- High IF Frequency up to 40 GHz and Beyond
- Compact Package

Typical Conversion Loss vs. Frequency

LO: +3 dBm, RF: -20 dBm, Bias: +5 Vdc/2 mA

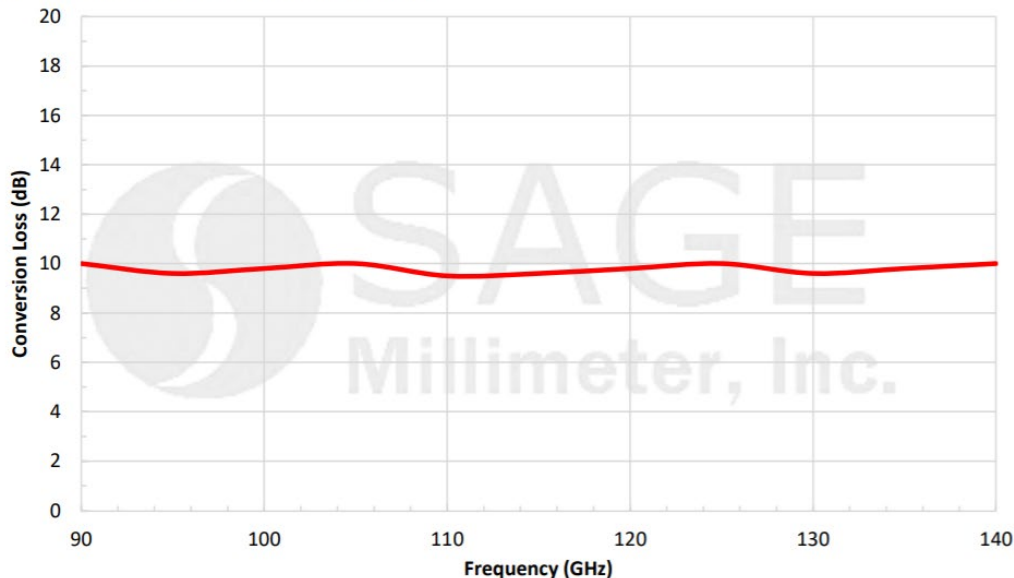

Balanced Upconverter

Model SFU-08-N1

Parameter	Minimum	Typical	Maximum
RF Frequency	90 GHz		140 GHz
LO Frequency	90 GHz		140 GHz
IF Frequency	DC		40 GHz
LO Pumping Power		+13 dBm	+15 dBm
Conversion Loss		13 dB	16 dB
Input P _{1dB}		-5 dBm	
RF to LO Isolation		30 dB	
Combined RF and LO Power			+18 dBm

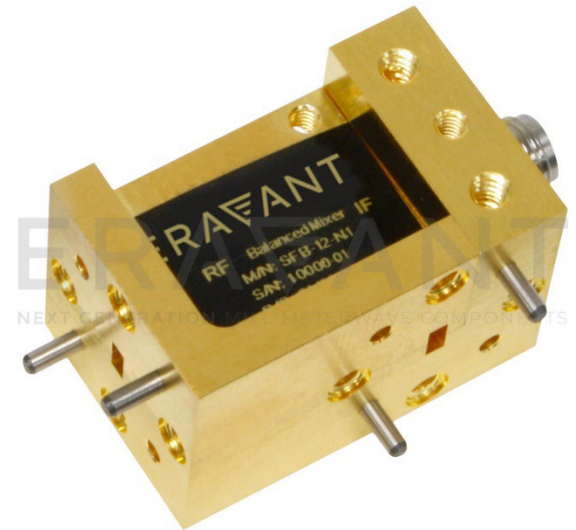

Typical Conversion Loss vs. Frequency

RF: -20 dBm; LO: 115 GHz/+12 dBm

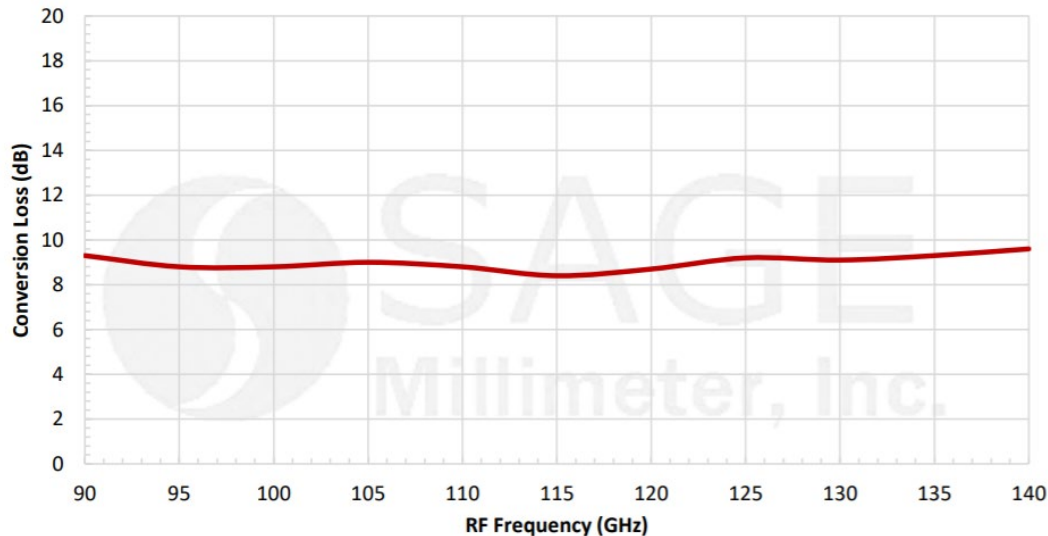

Features

- Full Waveguide Band Coverage
- Low Conversion Loss
- High IF Frequency up to 40 GHz and Beyond
- Compact Package

Externally Biased Upconverter

Model SFU-08-E2

Parameter	Minimum	Typical	Maximum
RF Frequency Range	90 GHz		140 GHz
LO Frequency Range	90 GHz		140 GHz
IF Frequency Range	DC		40 GHz
Required LO Pumping Power	+0 dBm	+3 dBm	+10 dBm
Conversion Loss		14 dB	
Input P-1 dB		-8 dBm	
Combined RF and LO Power			+18 dBm
External Bias Voltage		+5 V _{DC} /2mA	+5 V _{DC} /5mA



Features

- Full Waveguide Band Coverage
- Low Conversion Loss
- High IF Frequency up to 40 GHz and Beyond
- Compact Package

Typical Conversion Loss vs. Frequency

IF: -20 dBm, LO: 115 GHz/+3 dBm, Bias: +5 Vdc/2 mA

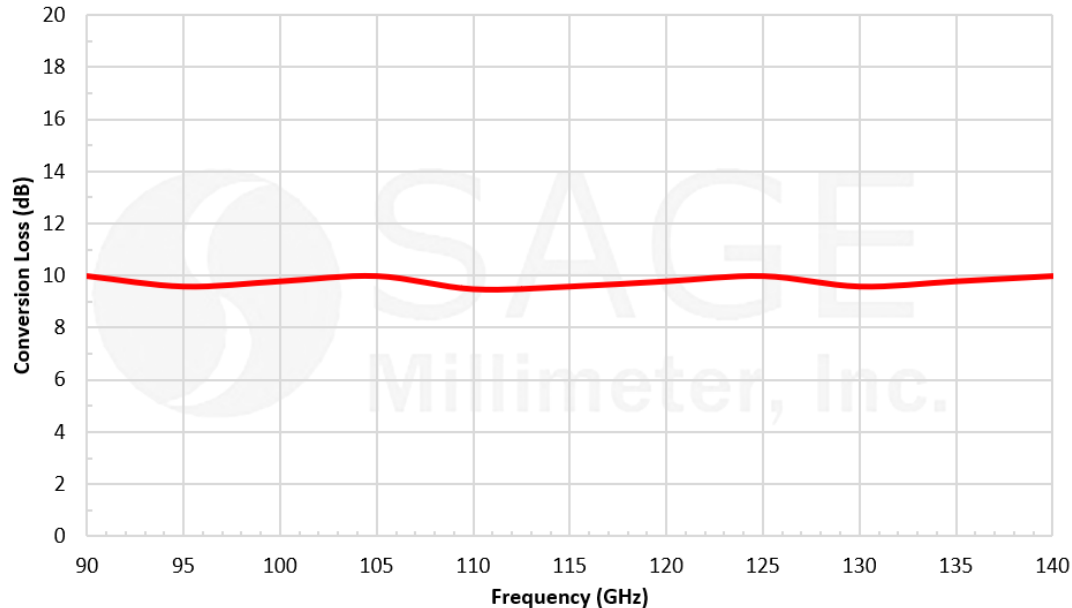

Subharmonically Pumped Mixer

Model SFS-08-N3

Parameter	Minimum	Typical	Maximum
RF Frequency	90 GHz		140 GHz
LO Frequency	45 GHz		70 GHz
IF Frequency	DC		5 GHz
LO Pumping Power		+16 dBm	
Conversion Loss		16 dB	
LO to IF Isolation		30 dB	
Combined RF and LO Power			+20 dBm

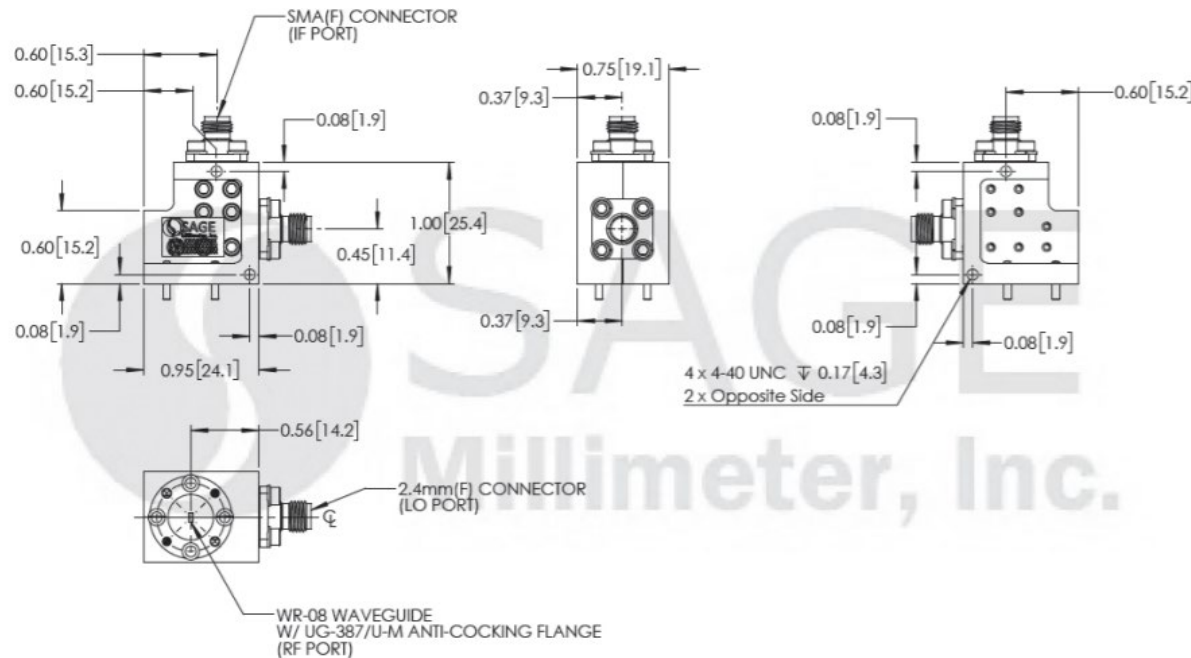

Features

- Full Band Operation
- LO=1/2 RF
- Second Harmonic Mixing
- Compact Package

Harmonic Mixer

Model SFH-08SFSF-A3

Parameter	Minimum	Typical	Maximum
RF Frequency	90 GHz		140 GHz
LO Frequency	3.0 GHz		6.1 GHz
IF Frequency	DC		1.3 GHz
LO Pumping Power		+16 dBm	+19 dBm
Harmonic Number		24	
Conversion Loss		48 dB	
Combined RF and LO Power			+20 dBm

Typical Conversion Loss vs. Frequency

$P_{RF} = -20$ dBm

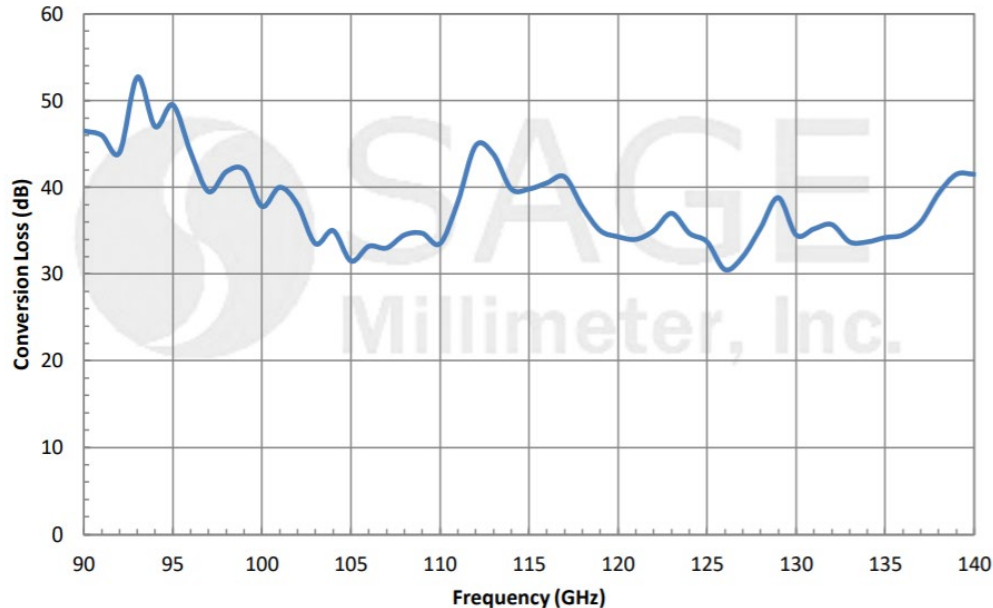

Features

- Full Band Operation
- Even Harmonics
- Balanced
- No External Bias Required
- 24th Harmonic Calibrated
- Other Even Harmonic Calibration Table Available
- Compact Package

Harmonic Mixer

Model SFH-08SFSF-A3-2

Parameter	Minimum	Typical	Maximum
RF Frequency	90 GHz		140 GHz
LO Frequency	5.0 GHz		12.0 GHz
IF Frequency	DC		1.6 GHz
LO Pumping Power		+16 dBm	+19 dBm
Harmonic Number		12	
Conversion Loss		42 dB	
Combined RF and LO Power			+20 dBm

Typical Conversion Loss vs. Frequency

$P_{RF} = -20$ dBm

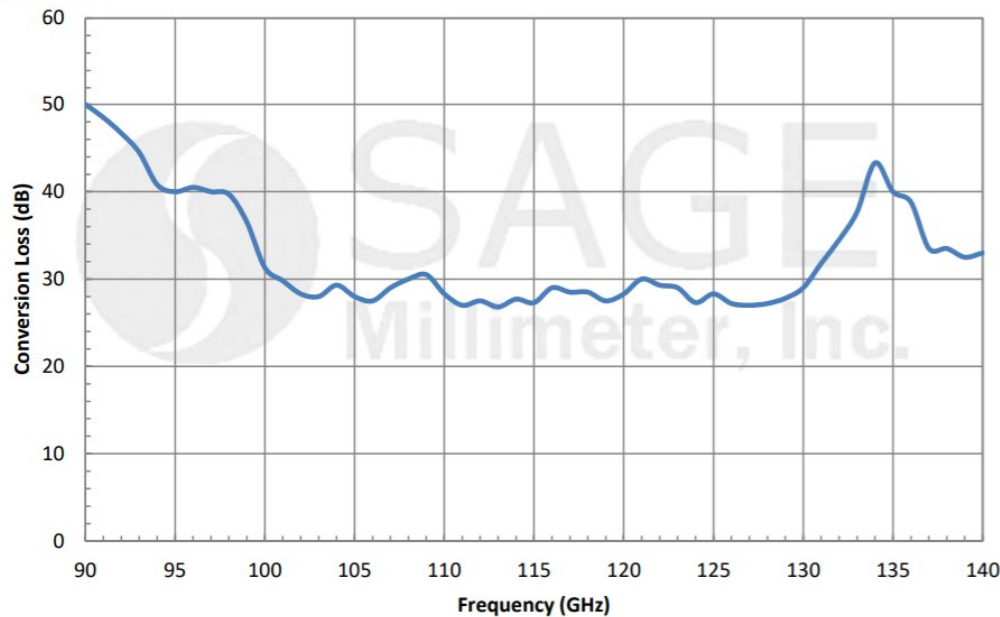

Features

- Full Band Operation
- Even Harmonics
- Balanced
- No External Bias Required
- 12th Harmonic Calibrated
- Other Even Harmonic Calibration Table Available
- Compact Package

Harmonic Mixer

Model STH-08SF-S1

Parameter	Minimum	Typical	Maximum
RF Frequency	90 GHz		140 GHz
LO Frequency	4.0 GHz		14.0 GHz
IF Frequency	DC		2.0 GHz
LO Pumping Power	+10 dBm	+13 dBm	+16 dBm
Harmonic Number		14	
Conversion Loss		45 dB	
Combined RF and LO Power			+20 dBm

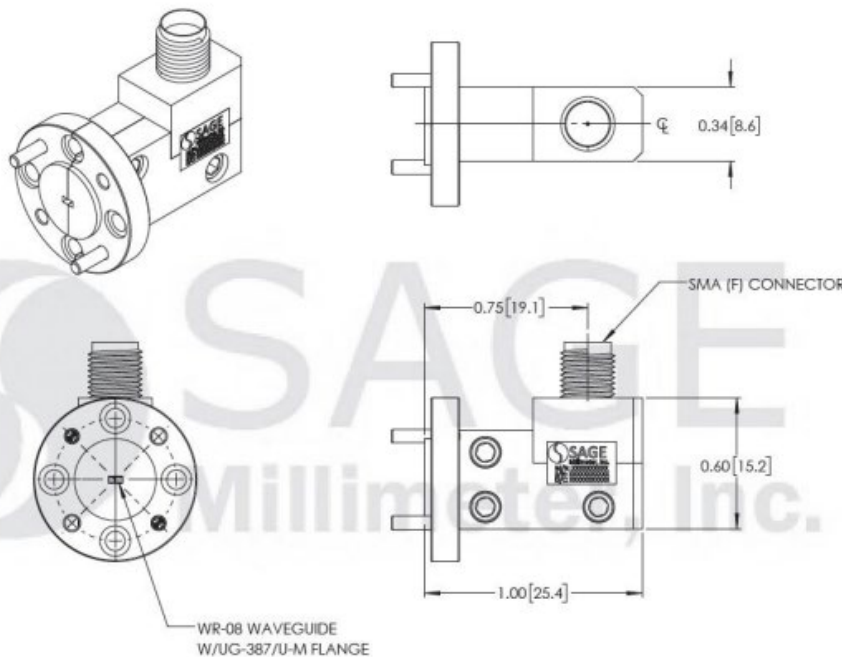

Features

- Full Band Operation
- Single Ended
- Single LO/IF Port
- No External Bias Required
- 14th Harmonic Calibrated
- Other Even Harmonic Calibration Table Available
- Compact Package

Amplitude Detector

Models SFD-903144-08SF-N1 and SFD-903144-08SF-P1

Parameter	Minimum	Typical	Maximum
Frequency Range	90 GHz		140 GHz
Sensitivity (SFD-114174-06SF-N1)		-300 mV/mV	
Sensitivity (SFD-114174-06SF-P1)		+300 mV/mV	
Sensitivity Flatness		± 2.0 dB	
Linear Detection Range	-45 dBm	-10 dBm	0 dBm
RF Input Power		-20 dBm	+17 dBm
Video Bandwidth		10 MHz	



Typical Performance vs. Frequency

$P_{in} = -20$ dBm



Features

- Full Waveguide Band Operation
- Positive and Negative Output Selection
- High Sensitivity Without Tuning
- High Sensitivity Stability Over Broad Temperature Range
- The Models with Integrated Faraday Isolator Available under **STD-08SF-NI** and **STD-08SF-PI**.

Amplitude Detector with Isolator

Models STD-08SF-NI and STD-08SF-PI

Parameter	Minimum	Typical	Maximum
Frequency Range	90 GHz		140 GHz
Sensitivity (STD-06SF-NI)		-300 mV/mV	
Sensitivity (STD-06SF-PI)		+300 mV/mV	
Sensitivity Flatness		± 2.0 dB	
Linear Detection Range	-45 dBm	-10 dBm	0 dBm
RF Input Power		-20 dBm	+17 dBm
Video Bandwidth		10 MHz	



Typical Performance vs. Frequency

$P_{in} = -20$ dBm

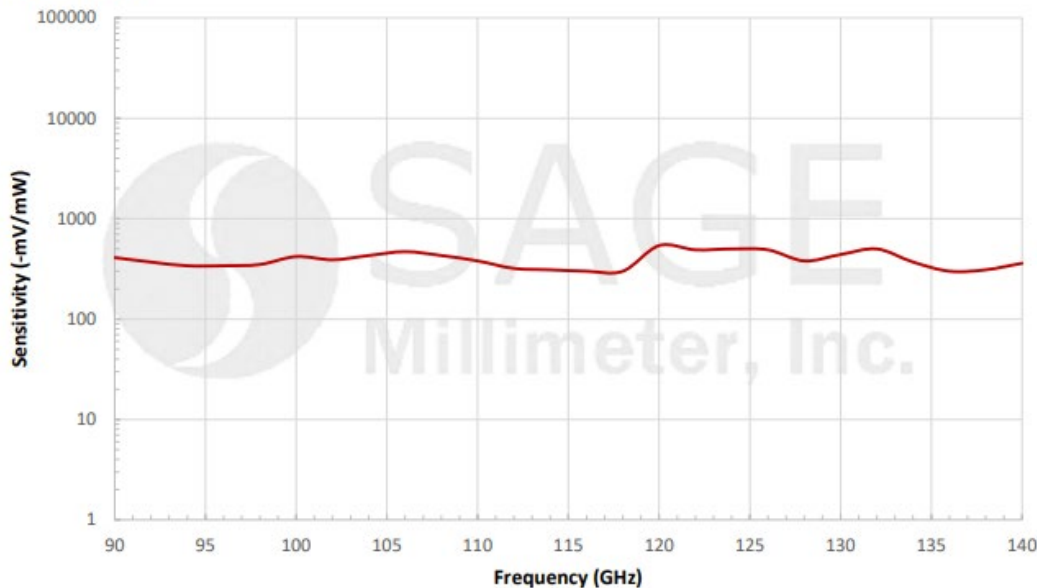

Features

- Full Waveguide Band Operation
- Positive and Negative Output Selection
- High Sensitivity Without Tuning
- High Sensitivity Stability Over Broad Temperature Range
- The Models without Integrated Faraday Isolator Available under **SFD-903144-08SF-N1** and **SFD-903144-08SF-P1**.

Waveguide Directional Coupler

Model SWD-2030H-08-SB

Parameter	Minimum	Typical	Maximum
Frequency	90 GHz		140 GHz
Insertion Loss*		2.5 dB	
Coupling*		20 dB	
Directivity*		25 dB	
Main Line VSWR			1.2:1



Mechanical Outline: (Unless otherwise specified, all dimensions are in inches)

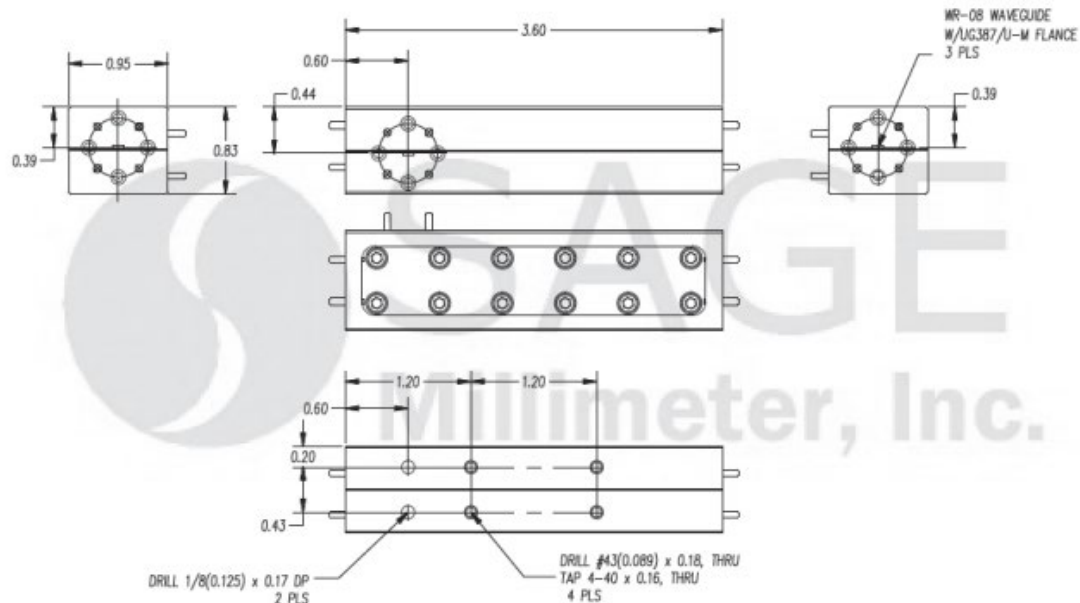

Features

- Full Band Operation
- 3, 6, 10, 20, 30, 40 dB
- Dual Directional
- Bi-Directional
- Waveguide Version
- Low Insertion Loss
- High Directivity

Waveguide Bandpass Filter

Model SWF-13435330-08-B1

Parameter	Minimum	Typical	Maximum
Passband Frequency	105 GHz		140 GHz
Passband Insertion Loss		2.5 dB	
Passband Ripple		± 1.0 dB	
Rejection Frequency, Low Side	DC		94 GHz
Rejection Frequency, High Side	145 GHz		180 GHz
Rejection		40 dB	
Passband Return		14 dB	



Simulated Data

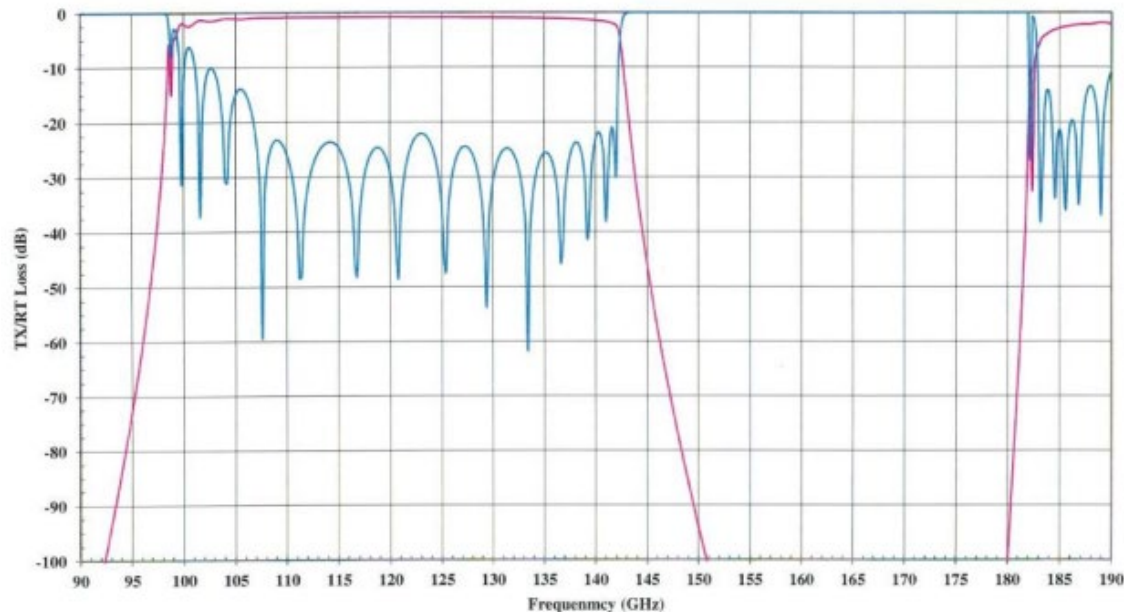

Features

- Lowpass, Highpass and Bandpass
- Narrow and Broadband
- Low Insertion Loss
- High Rejection

Waveguide Highpass Filter 130 GHz

Model SWF-13412460-08-H1

Parameter	Minimum	Typical	Maximum
Passband Frequency	130 GHz		>200 GHz
Passband Insertion Loss		2.5 dB	
Rejection Frequency	DC		124 GHz
Rejection		80 dB	
Passband VSWR		1.5:1	
Waveguide		WR-06	



Typical Insertion and Return Loss vs Frequency

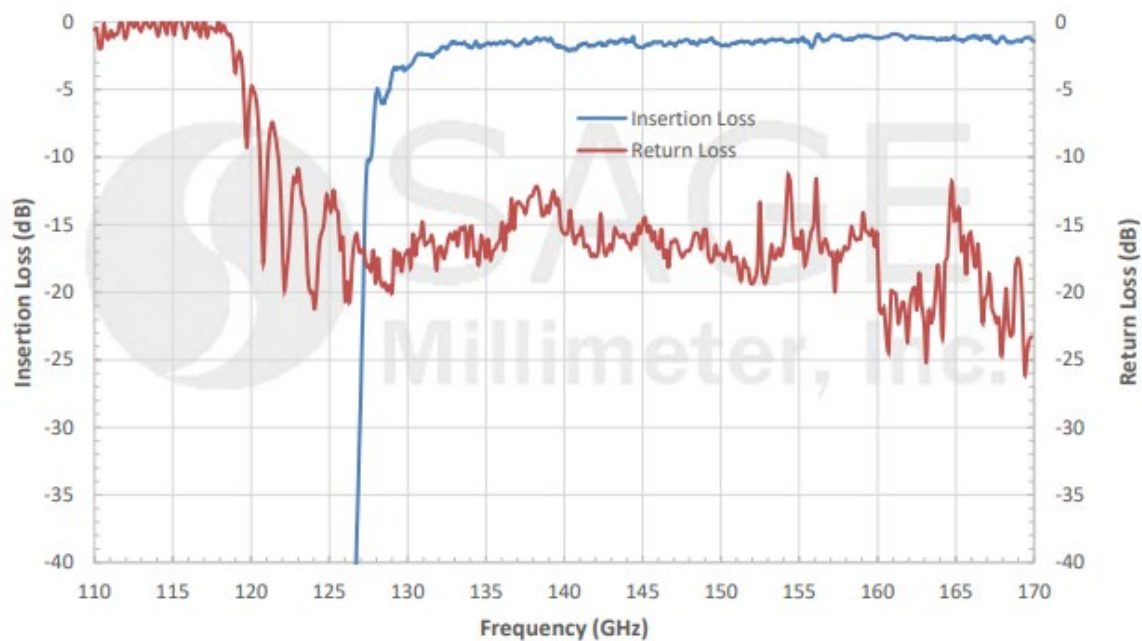

Features

- Lowpass, Highpass and Bandpass
- Narrow and Broadband
- Low Cost
- Low Insertion Loss
- High Rejection

Waveguides

- Metrology Grade Straight: 2.5"
- Straights: 1", 2", 3", 4" etc. and Custom Length
- Bends, H and E-Plane, 45 °, 90° and Custom Angle
- Twists, 45 °, 90° and Custom Angle



Waveguide E-Bend: 90°



Waveguide H-Bend: 90°



Waveguide Straight: 2.5"
Metrology Grade



Waveguide Straight: 2"



Waveguide Twist: 90°

Faraday Isolator, Full Band

Model STF-08-S1 and STF-08-91

Parameter	Minimum	Typical	Maximum
RF Frequency	90 GHz		140 GHz
Insertion Loss		2.0 dB	
Isolation		30 dB	
Return Loss		14 dB	
Power Handling		0.8 W (CW)	1.0 W (CW)



Typical Performance vs. Frequency

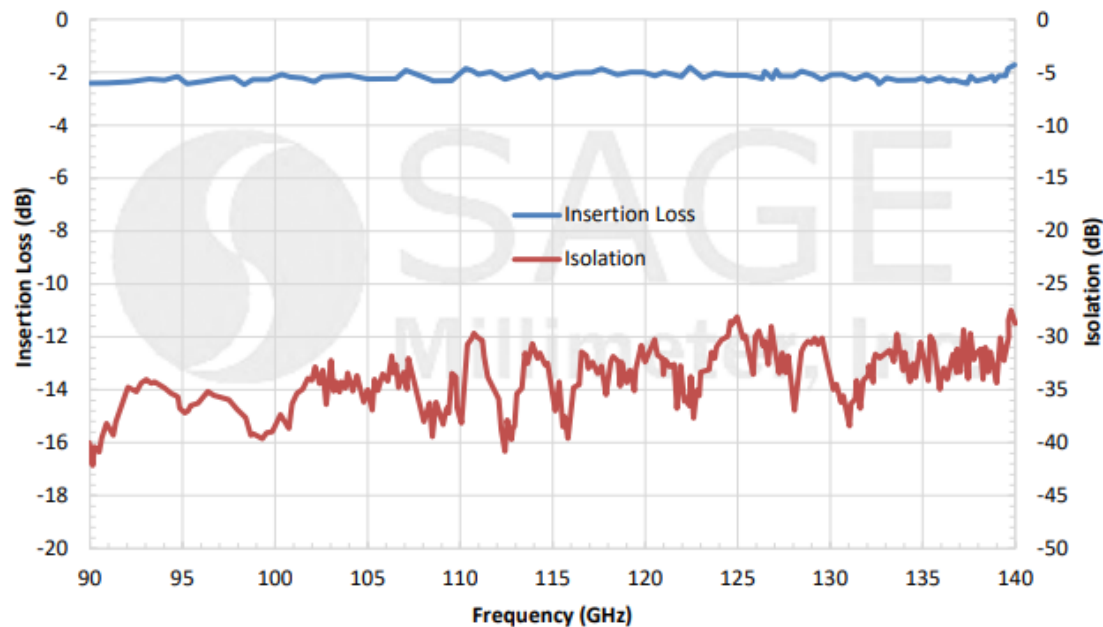

Features

- Full Waveguide Band
- Instrumentation Grade
- Various Port Orientations
- Compact Options
- Low Insertion Loss
- High Rejection

Faraday Isolator, Compact, Full Band

Model STF-08-S1-C and STF-08-91-C

Parameter	Minimum	Typical	Maximum
RF Frequency	90 GHz		140 GHz
Insertion Loss		2.0 dB	
Isolation		28 dB	
Return Loss		14 dB	
Power Handling		0.8 W (CW)	1.0 W (CW)



Typical Performance vs. Frequency

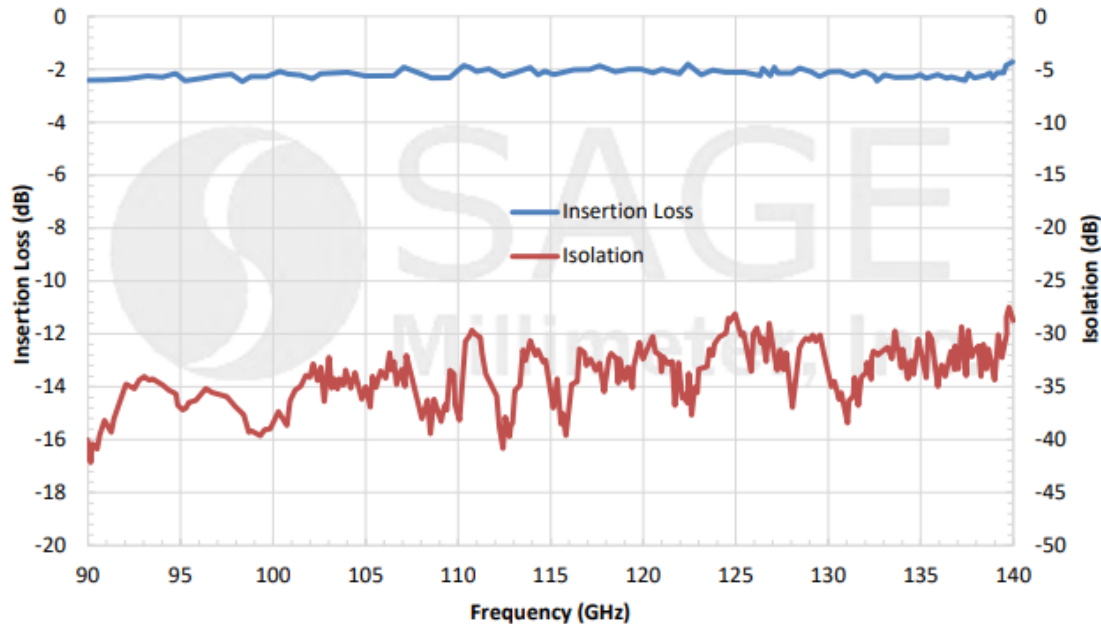

Features

- Full Waveguide Band
- Instrumentation Grade Options
- Various Port Orientations
- Low Insertion Loss
- High Rejection

Full Band VNA Frequency Extender

Model STO-08203-U6

Features

- Full Band Coverage
- Dynamic Range of 110 dB
- AC Power Input: 100 to 240 VAC

Applications

- Dual Source and 4 Port VNA Extension
- E band S-Parameter Measurement
- Test Lab Instrumentation



Parameter	Minimum	Typical	Maximum
RF Operating Frequency	90 GHz		140 GHz
Test Port Output Power		+1 dBm	
Output Power Control Range	0 to 20 dB		
Dynamic Range @ 10 Hz Bandwidth	100 dB	110 dB	
Test Port Match		30 dB	
Directivity	35 dB	40 dB	
RF Source Input Frequency	7.5 GHz		11.66 GHz
RF Source Input Power	0 dBm	+3 dBm	+6 dBm
LO Source Input Frequency (RF \pm IF)	7.5 GHz		11.66 GHz
LO Source Input Power	0 dBm	+3 dBm	+6 dBm

Full Band Waveguide Calibration Kit

Model STQ-TO-08-S1-CKIT1

Features

- Precisely Machined and Manufactured
- Metrology Grade
- High Electrical Performance

Applications

- Vector Network Analyzer Calibration
- Scalar Network Analyzer Calibration
- General Test Lab Instrumentation



Components Included in the Kit:

Item	SAGE Model Number	Quantity
Metrology Fixed Short	STQ-WS-VG-F1	1 Piece
Metrology Fixed Waveguide Load	STQ-WL-0823-S1	1 Piece
Metrology $\frac{1}{8}$ Wavelength Offset	STQ-WI-08017-SB	1 Piece
Metrology $\frac{1}{4}$ Wavelength Offset	STQ-WI-08033-SB	1 Piece
Metrology $\frac{3}{8}$ Wavelength Offset	STQ-WI-08050-SB	1 Piece
Waveguide Quick Connect, 0.75" Diameter Flange	SWH-QC-0750C-R2	2 Pieces
Waveguide Screws, 3/32 Hex Head	SWH-332-SS-10	1 Bag (10 Pieces)
Waveguide Screwdriver, 3/32 Hex Head	SWH-332-DS	1 Piece
Calibration Data, USB Drive	STQ-TO-08-S1-U	1 Piece

Full Band Frequency Extender

Model STE-2F308-00-S1

Features

- Full Waveguide Band Operation
- High Output Power
- Low Harmonics and Spurious Emission
- Cost Effective
- Many Other Modes
- Instrumentation Grade
- Adjustable/Removable Legs



Applications

- Network Analyzer Systems
- Frequency Sources
- Test Instrumentations

Parameter	Minimum	Typical	Maximum
Output Frequency Range	90 GHz		140 GHz
Input Frequency Range	30 GHz		46.67 GHz
Output Power		+3 dBm	
Input Power	+1 dBm	+5 dBm	+20 dBm
Harmonic Suppression		20 dBc	
Spurious Suppression		60 dBc	
DC Voltage	+13 V	+15V	+16 V
DC Current		450 mA	

Full Band Noise Figure and Gain Test Extender

Model STG-08-S1

Parameter	Minimum	Typical	Maximum
RF Frequency Range	90 GHz		140 GHz
Noise Source: ENR		12.0 dB	
Noise Source: Bias	+ 18 V _{DC} /50mA	+28 V _{DC} /60mA	+30 V _{DC} /75mA
IF Frequency Range	10 MHz		26.5 GHz
LO Frequency Range	10 GHz		15.5 GHz
LO Power	+3 dBm	+5 dBm	+20 dBm
N.F. Dynamic Range	0 dB		20 dB
Conversion Gain	15 dB	20 dB	
Down-Converter: Bias		+12 V _{DC} /450mA	+15 V _{DC} /550mA



Typical Performance vs. Frequency

V_{DC}= +28 V, I_{DC}= 60 mA

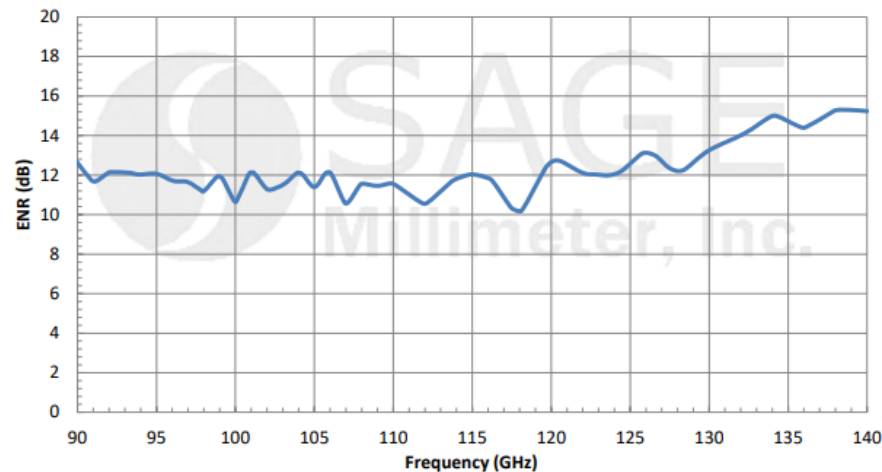

Model STZ-08-I1

ENR

Noise Source with Isolator

Model STZ-08-I1

Parameter	Minimum	Typical	Maximum
RF Frequency Range	90.0 GHz		140.0 GHz
ENR		12.0 dB	
ENR Flatness		± 3.0 dB	
Temperature Stability		0.01 dB/°C	
Long Term Temperature Stability		0.05 dB/day	
AM Modulation Trigger	TTL		
AM Modulation Rate	1.0 kHz		
DC Bias	+18 V _{DC} /35 mA	+28 V _{DC} /60 mA	+30 V _{DC} /75 mA



Typical Performance vs. Frequency

V_{DC} = +28 V, I_{DC} = 60 mA

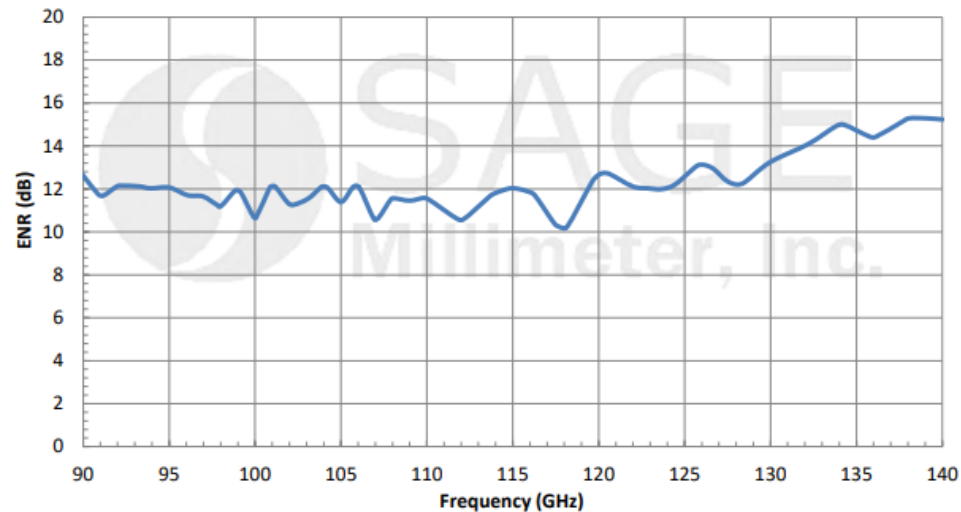

Fixed Attenuator

Model STA-10-08-F1

Features

- Full Band Coverage
- 3, 6, 10, 20, 30, 40, 50 dB
- Custom Attenuation Values

Applications:

- Test Lab
- Instrumentations
- System Integration



Typical Measured Attenuation vs Frequency

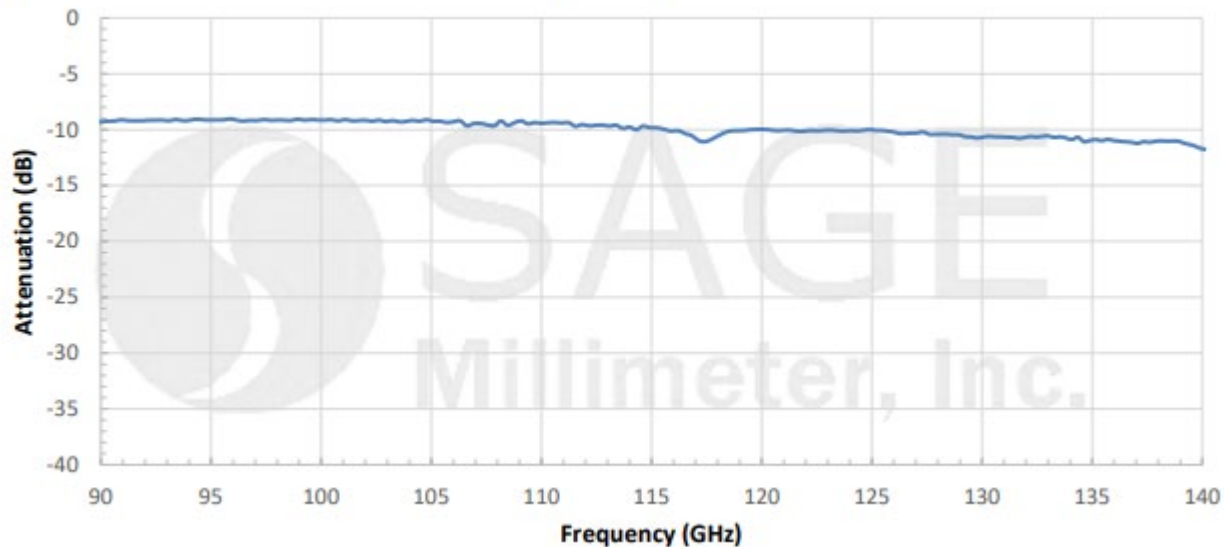

Level Setting Attenuator

Model STA-30-06-M1

Features

- Full Band Coverage
- Head Locking Screw
- Precision Machined Housing
- Convenient Level Setting

Applications:

- Test Lab
- Instrumentations
- Manual Test Set



Parameter	Minimum	Typical	Maximum
Frequency Range	110 GHz		170 GHz
Insertion Loss		1.7 dB	
Attenuation Range		30 dB	
Return Loss		20 dB	
Power Handling			300 mW (CW)
Specification Temperature		+25 °C	
Operating Temperature	-40 °C		+85 °C

Direct Reading Attenuator

Model STA-60-08-D1

Features

- Full Band Coverage
- High Attenuation Accuracy
- Large Scaled Dial

Applications:

- Test Lab
- Instrumentations
- Manual Test Set



Parameter	Minimum	Typical	Maximum
RF Frequency Range	90 GHz		140 GHz
Insertion Loss		1.5 dB	2.5 dB
Attenuation Range	0 dB		60 dB
Attenuation Accuracy	0.1 dB or 3% of reading, whichever is larger, up to 40 dB		
Return Loss		18 dB	
Power Handling (CW)		50 mW	100 mW

Digital Direct Reading Attenuator

Model STA-60-08-D5

Features

- Full Band Coverage
- High Attenuation Accuracy
- Digital Screen with Back Light

Applications:

- Test Lab
- Instrumentations
- Manual Test Set



Parameter	Minimum	Typical	Maximum
RF Frequency Range	90 GHz		140 GHz
Insertion Loss		1.5 dB	2.5 dB
Attenuation Range	0 dB		60 dB
Attenuation Accuracy	0.1 dB or 2% of Setting, whichever is larger, up to 40 dB		
Return Loss		18 dB	
Power Handling (CW)		100 mW	250mW

Programmable Attenuator

Model STA-60-08-P1

Features

- Full Band Coverage
- High Attenuation Accuracy
- IEEE-488 and USB Control Ports

Applications:

- Test Lab
- Instrumentations
- Auto Test Set



Parameter	Minimum	Typical	Maximum
RF Frequency Range	90 GHz		140 GHz
Insertion Loss		3.0 dB	
Attenuation Range	0 dB		70 dB
Attenuation Accuracy	0.1 dB or 3% of the reading, whichever is larger, up to 40 dB		
Return Loss		20 dB	
Power Handling (CW)		250 mW	500 mW

Check out our website for more!

www.eravant.com

Featuring

- 3,000+ Products with Full Datasheets
- Price and Delivery Available Online
- Product Categorization Filters
- Blogs, Calculators and Publications

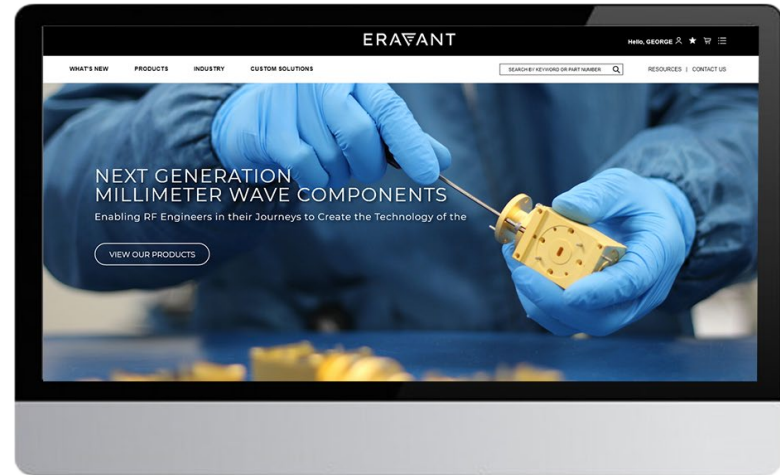

SWM-60390320-12-SB Rev. 1.0

Full E-Band Magic Tee

Description:
Model SWM-60390320-12-SB is an E-band magic tee that covers the entire band from 60 to 90 GHz. This magic tee is a four-port hybrid coupler and/or power divider with two collinear arms, an E-plane (difference) arm, and an H-plane (sum) arm. The magic tee offers less than 1.0 dB insertion loss and high isolation between the two collinear arms and between the sum and difference arms. All waveguide ports have standard WR-12 waveguides with UG-387/U Flanges.

Features:

- Low Insertion Loss and High Isolation
- Compact Package

Applications:

- Test Labs
- Test Instrumentation
- Sub-assemblies

Electrical Specifications:

Parameter	Minimum	Typical	Maximum
Frequency	60 GHz		90 GHz
Insertion Loss		0.35 dB	
Isolation		30 dB	
Collinear Ports		20 dB	
VSWR		1.5:1	

Mechanical Specifications:

Item	Specification
Sum and Difference Ports	WR-12 Waveguide with UG-387/U Flange
Collinear Ports	WR-12 Waveguide with UG-387/U Flange
Weight	1.2 Oz
Finishing	Gold Plated
Material	Aluminum
Outline	WM BE

www.sagemillimeter.com | 3043 Kashiba Street, Torrance, CA 90505
Phone: 424-751-0168 | Fax: 424-751-0168 | Email: sales@sagemillimeter.com

Copyright © 2015 by SAGE Millimeter, Inc.

SAGE Millimeter, Inc.

very well to unit, presented without notice.

ation and may damage the

www.sagemillimeter.com | 3043 Kashiba Street, Torrance, CA 90505
Phone: 424-751-0168 | Fax: 424-751-0168 | Email: sales@sagemillimeter.com

Copyright © 2015 by SAGE Millimeter, Inc.

www.sagemillimeter.com | 3043 Kashiba Street, Torrance, CA 90505
Phone: 424-751-0168 | Fax: 424-751-0168 | Email: sales@sagemillimeter.com

Copyright © 2015 by SAGE Millimeter, Inc.

PASSIVE FREQUENCY MULTIPLIERS

GRID TABLE 28 RESULTS

MODEL	MINIMUM OUTPUT FREQUENCY	MAXIMUM OUTPUT FREQUENCY	OUTPUT POWER	MINIMUM INPUT FREQUENCY	MAXIMUM INPUT FREQUENCY	INPUT POWER	OUTPUT PORT	INPUT PORT	DOWNLOADS	VIEW
SFP-06212-S2	110 GHz	170 GHz	0 dBm	55 GHz	85 GHz	+18 dBm	WR-08 Waveguide	WR-12 Waveguide	Datasheet	View
SFP-06319-U6	110 GHz	170 GHz	-3 dBm	36.67 GHz	56.67 GHz	+20 dBm	WR-05 Waveguide	WR-16 Waveguide	Datasheet	View
SFP-06510-S2	140 GHz	220 GHz	-3 dBm	70 GHz	110 GHz	+17 dBm	WR-05 Waveguide	WR-10 Waveguide	Datasheet	View
SFP-223403205-28SF-S1	22 GHz	40 GHz	+5 dBm	11 GHz	20 GHz	+18 dBm	WR-28 Waveguide	SMA (F)	Datasheet STEP File	View
SFP-243423303-28SF-S1	24 GHz	42 GHz	+3 dBm	8 GHz	14 GHz	+20 dBm	WR-28 Waveguide	SMA (F)	Datasheet STEP File	View
SFP-2835F-U9	26.5 GHz	40.0 GHz	+5 dBm	8.37 GHz	13.33 GHz	+20 dBm	WR-28 Waveguide	SMA (F)	Datasheet	View
SFP-2734033105-28SF-S1	26.5 GHz	40 GHz	-5 dBm	8.37 GHz	13.33 GHz	+10 dBm	WR-28 Waveguide	SMA (F)	Datasheet STEP File	View
SFP-2235F-S1	33 GHz	50 GHz	+3 dBm	11 GHz	16.67 GHz	+20 dBm	WR-22 Waveguide	SMA (F)	Datasheet STEP File	View
SFP-222KF-S1	33 GHz	50 GHz	+7 dBm	16.5 GHz	25 GHz	+20 dBm	WR-22 Waveguide	2.82 mm (F)	Datasheet STEP File	View
SFP-363573303-19SF-N1	57 GHz	36 GHz	+3 dBm	12 GHz	19 GHz	+20 dBm	WR-19 Waveguide	SMA (F)	Datasheet STEP File	View
SFP-192KF-S1	40 GHz	60 GHz	+6 dBm	20 GHz	30 GHz	+20 dBm	WR-19 Waveguide	2.92 mm (F)	Datasheet STEP File	View