



WR-19 Waveguide Short, Tunable

Description:

Model SWS-19-T1 is a tunable waveguide short that covers the frequency range of 40 to 60 GHz. The tunable short is constructed with a linear bearing and high precision Mitutoyo micrometer to guarantee smooth, long term repeatable mechanical movements. The tunable short is an ideal instrument for applications where phase variation is required. The tunable short offers a 20:1 typical VSWR.



Features:

- High VSWR
- Linear Bearing Configuration
- Mitutoyo Micrometer Driven

Applications:

- Test Labs
- Test Instrumentation
- System Calibration and Tuning

Electrical Specifications:

Parameter	Minimum	Typical	Maximum
Frequency	40 GHz		60 GHz
VSWR		20:1	
Power Handling			1.0 W
Specification Temperature		+25°C	
Operating Temperature	-40°C		+85°C

Mechanical Specifications:

Item	Specifications
Waveguide	WR-19 Waveguide with UG-383/U-M Flange
Waveguide Tube	Copper
Waveguide Flange Material	Brass
Finish	Gold Plated Waveguide; Black Anodized Handle
Weight	4.5 Oz
Outline	WS-UT



WR-19 Waveguide Short, Tunable

Mechanical Outline: (Unless otherwise specified, all dimensions are in inches)

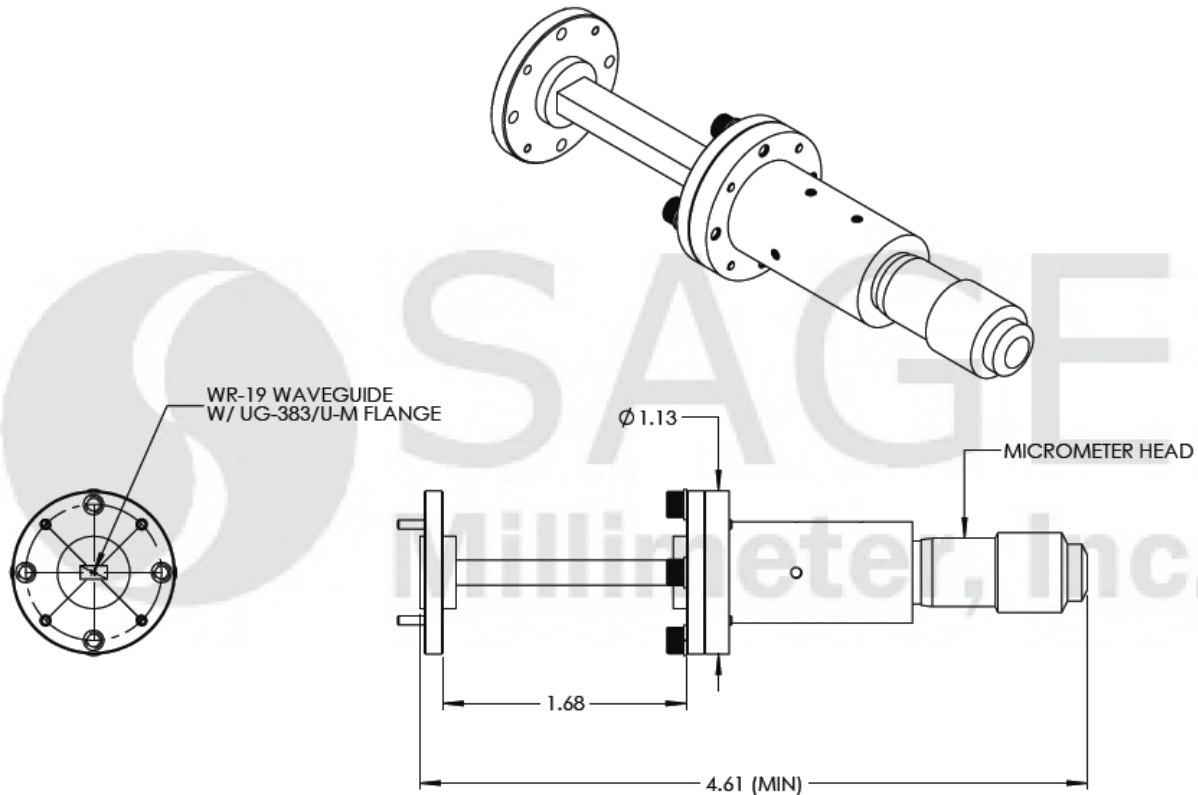

Note:

- SAGE Millimeter, Inc. reserves the right to change the information presented without notice.

Caution:

- Any foreign objects in the waveguide will degrade performance and/or damage the device.

