

SWS-15-T1

WR-15 Waveguide Short, Tunable

SWS-15-T1 is a tunable waveguide short that covers the frequency range of 50 to 75 GHz. The tunable short is constructed with a linear bearing and high precision, Mitutoyo micrometer to guarantee smooth, long term repeatable mechanical movements. The tunable short is an ideal instrument for applications where phase variation is required. The tunable short offers a 20:1 typical VSWR.



Electrical Specifications:

Parameter	Minimum	Typical	Maximum
Frequency	50 GHz		75 GHz
VSWR		20:1	
Specification Temperature		+25°C	
Operating Temperature	-40°C		+85°C

Mechanical Specifications:

Item	Specification
Waveguide	WR-15 Waveguide with UG-385/U Flange
Waveguide Material	Brass
Finish	Gold Plated Waveguide; Black Anodized Handle
Weight	3.5 Oz
Outline	WS-VT

ECCN

EAR99

FEATURES

- High VSWR
- Linear Bearing Configuration
- Mitutoyo Micrometer Driven

APPLICATIONS

- Test Labs
- Test Instrumentation
- System Calibration and Tuning

SUPPLEMENTAL DETAILS



SWS-15-T1

Mechanical Outline: (Unless otherwise specified, all dimensions are in inches [millimeters])

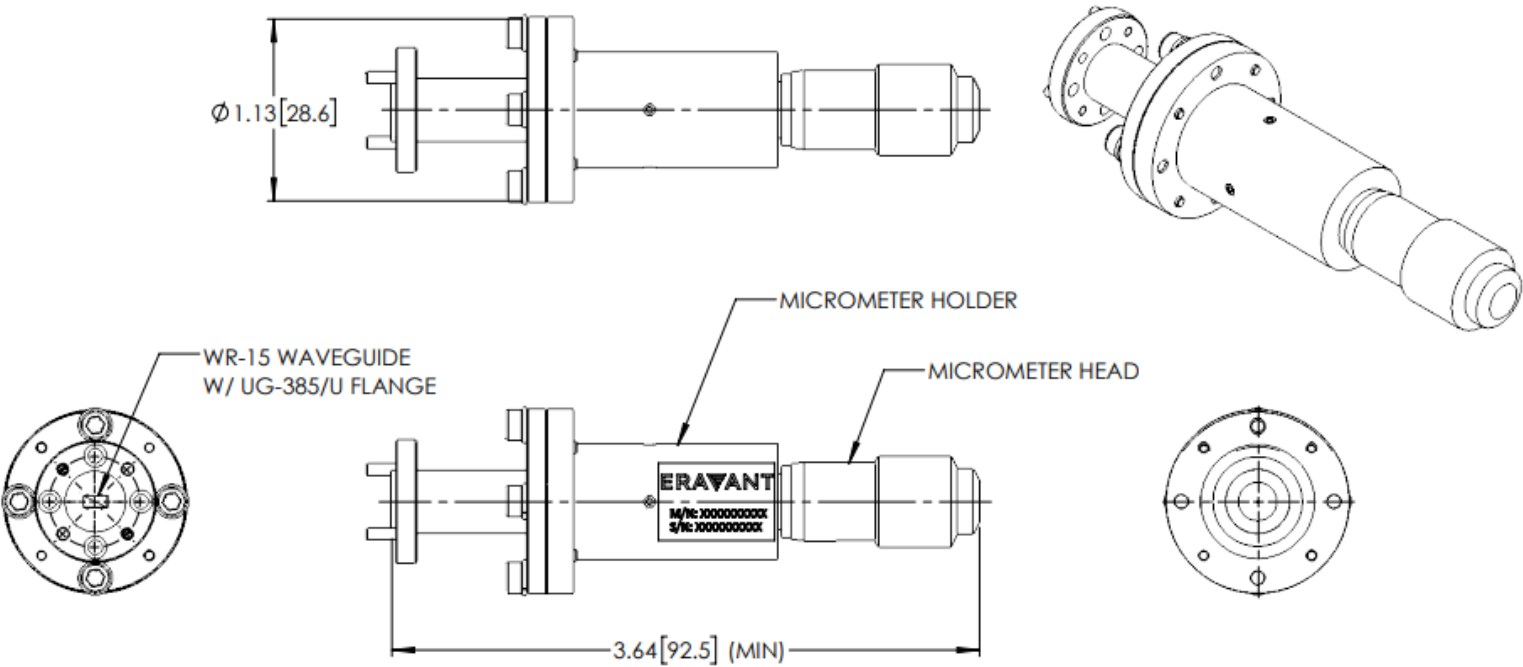

NOTE:

- On condition that test data is provided it is collected from a sample lot. Actual data may vary slightly from unit to unit. All testing is performed under +25 °C room temperature.
- On condition that simulated test data is provided, actual measured data may slightly vary.
- Eravant reserves the right to change the information presented without notice.

CAUTION:

- If a waveguide is present, any foreign objects in the waveguide will cause performance degradation and may damage or destroy the unit.
- Exceeding absolute maximum ratings shown will damage the device.
- Any foreign objects in the waveguide will degrade performance and/or damage the device.

