

V-Band Waveguide Termination Load, 5 Watts

Description:

Model SWL-1537-S1 is a medium power, V-Band termination load that covers the frequency range of 50 to 75 GHz. The termination load exhibits a typical return loss of 30 dB. It is designed and manufactured to offer a good match for system applications. Custom levels of power handling are available under different model numbers.



Features:

- Full Waveguide Band Coverage
- High Return Loss
- Instrumentation Grade

Applications:

- Test Lab
- Instrumentations
- Sub-assemblies

Electrical Specifications:

Parameter	Minimum	Typical	Maximum
Frequency	50 GHz		75 GHz
Return Loss		30 dB	
Power Handling		5 W (CW)	6 W (CW)
Specification Temperature		+25°C	
Operating Temperature	-40°C		+85°C

Mechanical Specifications:

Item	Specification
RF Ports	WR-15 Waveguide with UG-385/U Flange
Waveguide Material	Brass
Waveguide Finish	Gold Plated
Heat Sink Finish	Black Anodized
Weight	2.0 Oz
Outline	WL-VM



V-Band Waveguide Termination Load, 5 Watts

Typical Return Loss vs. Frequency

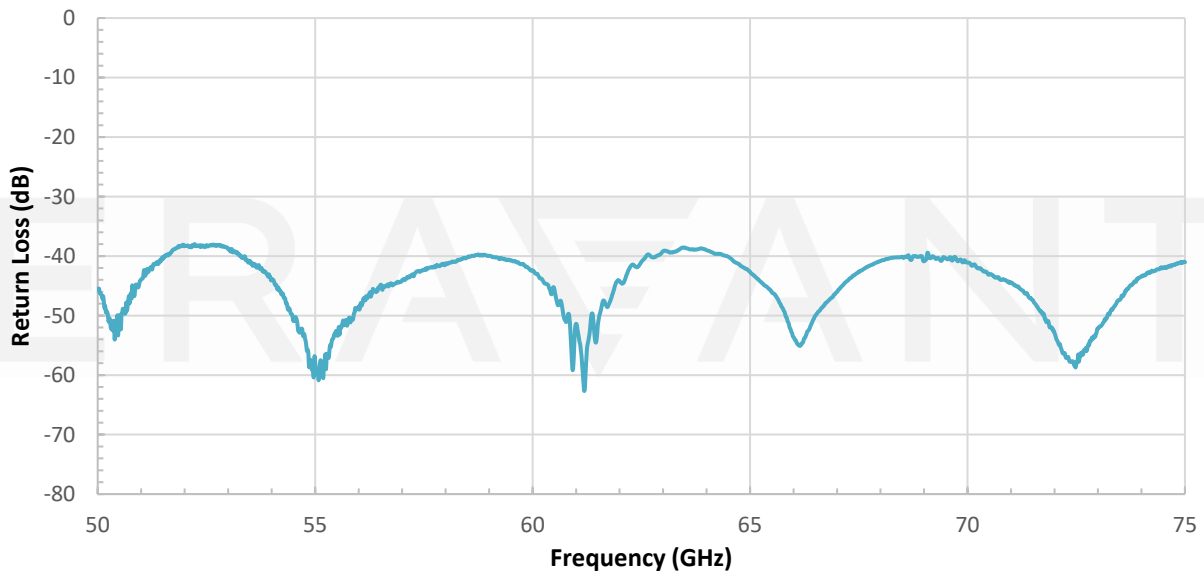

Mechanical Outline: (Unless otherwise specified, all dimensions are in inches [millimeters])

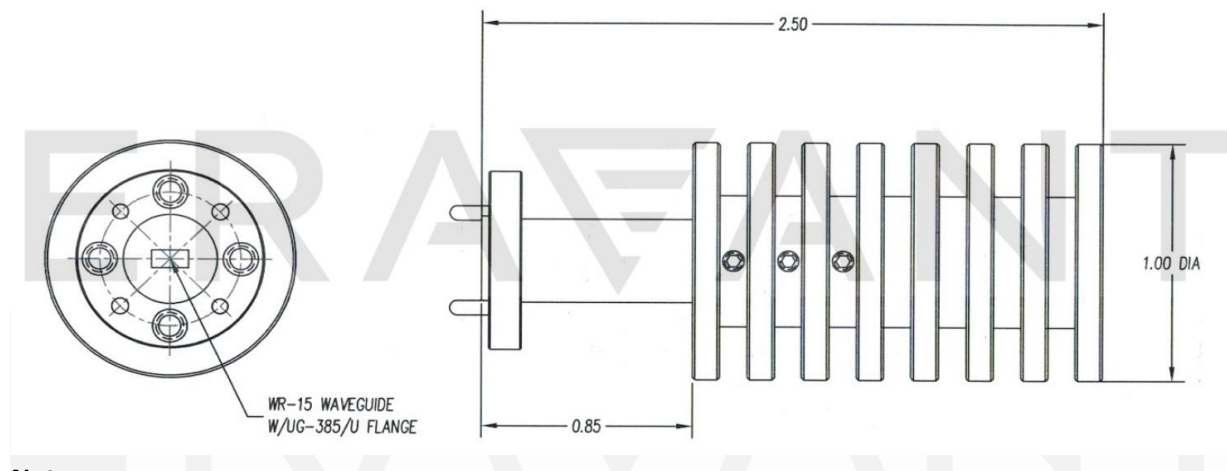

Note:

- Return loss data presented was measured under low power conditions (0 dBm). Actual return loss under high power conditions will be worse than what is shown on the plot.
- All data are presented using a limited sample lot. Actual data may vary unit to unit.
- All testing was performed under 25°C case temperature.
- Eravant reserves the right to change the information presented without notice.

Caution:

- Exceeding absolute maximum ratings shown will damage the device.
- Any foreign objects in the waveguide will cause performance degradation and possible device damage.



www.eravant.com | 501 Amapola Ave, Torrance, CA 90501
 Phone: 424-757-0168 | Fax: 424-757-0188 | Email: support@eravant.com