

WR-75 Flexible Twistable Waveguide Section, 11.81" (300 mm)

Description:

Model SWG-75118-FB-FT-G is a 11.81" (300 mm) long, WR-75 flexible and twistable waveguide section with a WR-75 waveguide and a standard grooved square flange. It also has a vulcanized silicone rubber jacket for robustness applications. The waveguide features a flexible bend with a static twist to be long-term stress free when it is integrated into systems. The flanges of the waveguide are grooved to accept rubber rings to be watertight for outdoor applications. The waveguide is manufactured with a precision manufacturing process to ensure high quality. The waveguide has low insertion loss in the frequency range of 10 to 15 GHz. Additional standard lengths and custom length options are available under different model numbers.



Features:

- High Quality
- Flexible Bending and Static Twisting
- Comparable Cost to the Rigid Waveguide

Applications:

- Communication Systems
- Various Outdoor Equipment

Electrical Specifications:

Parameter	Minimum	Typical	Maximum
Frequency	10 GHz		15 GHz
Insertion Loss		0.15 dB	
Return Loss		25 dB	
Power Handling			750 W (CW)
Specification Temperature		+25 °C	
Operation Temperature	-40 °C		+85 °C

Mechanical Specifications:

Item	Specification
Waveguide Port	WR-75 Waveguide with Standard Grooved Flange
Minimum Bending Radius (Static)	E-plane: 2.1" (54 mm); H-plane: 4.3" (108 mm)
Minimum Bending Radius (Dynamic)	E-plane: 8.5" (216 mm); H-plane: 17" (432 mm)
Maximum Torsion Angle (Static)	365°/meter
Maximum Torsion Angle (Dynamic)	92°/meter
Material	Brass
Flange Finish	Nickel Plated
Waveguide Finish	Silver Plated
Waveguide Jacket Material	Vulcanized Silicone Rubber
Weight	11 Oz
Insertion Length	11.81" (300 mm) (±3%)
Outline	WG-F7-FT-G-L



WR-75 Flexible Twistable Waveguide Section, 11.81" (300 mm)

Typical Performance vs. Frequency

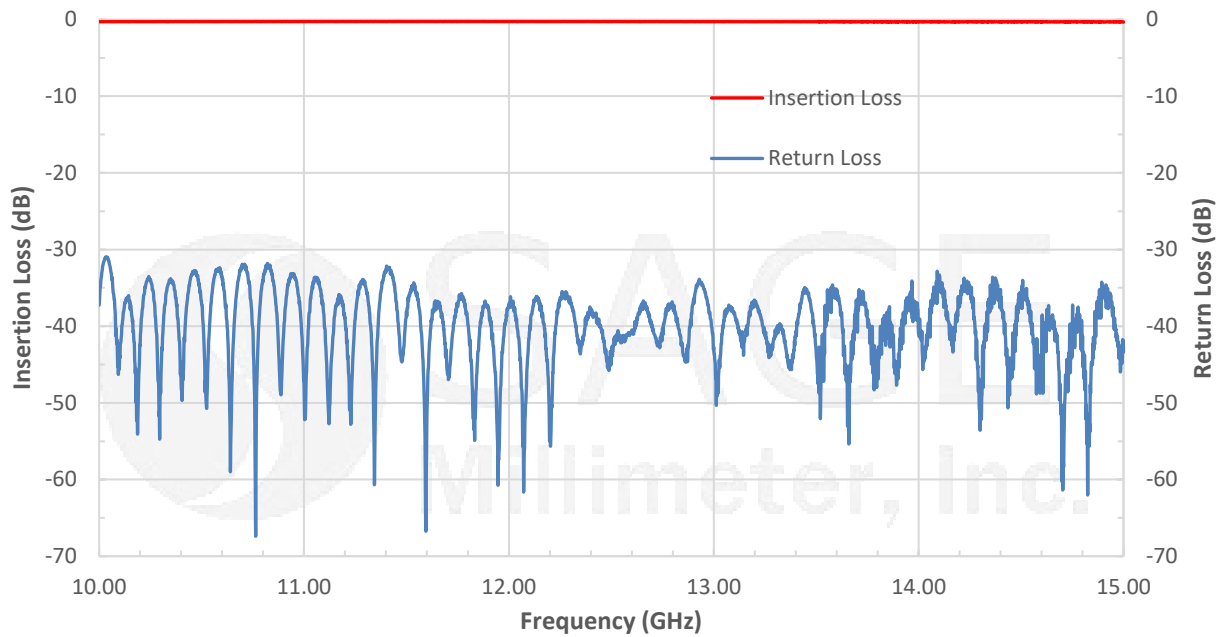

Mechanical Outline: (Unless otherwise specified, all dimensions are in inches [millimeters])

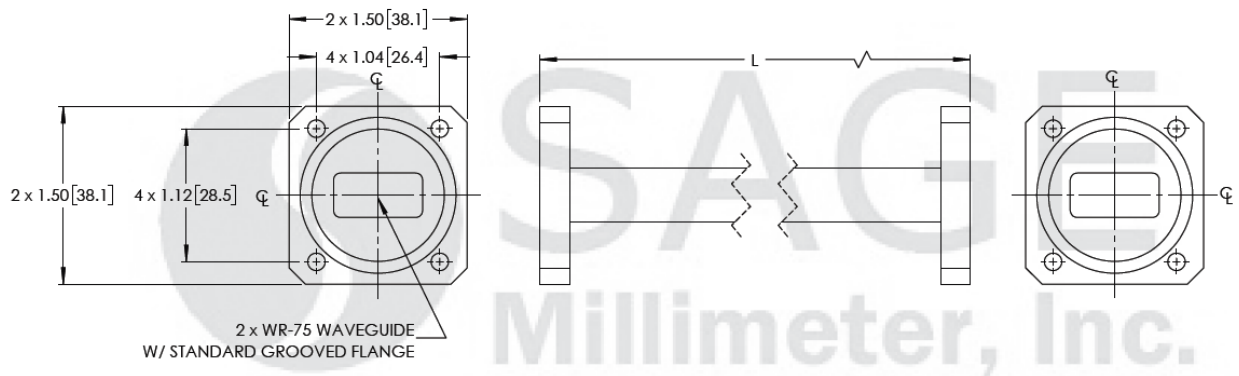

Note:

- Length "L" is customizable.
- All data presented is collected from a sample lot. Actual data may vary unit to unit.
- All testing was performed under +25 °C case temperature.
- Other mechanical configurations are available under different model numbers.
- SAGE Millimeter, Inc. reserves the right to change the information presented without notice.

Caution:

- Exceeding absolute maximum ratings shown will damage the device.
- Any foreign objects in the waveguide will cause performance degradation and possible device damage.

