



Waveguide Bandpass Filter, E Band, 69 to 71 GHz

Description:

Model SWF-70302340-12-B1 is an E band waveguide bandpass filter with a passband frequency of 69 to 71 GHz and rejection frequencies from DC to 66 GHz and 74 to 90 GHz. The nominal insertion loss of the bandpass filter is 1.5 dB and the typical rejection is 40 dB. Since both low end and high end cut off frequencies can be selected by modifying the design, custom designs are available under different model numbers.



Features:

- Low Cost
- Low Insertion Loss
- High Rejection

Applications:

- E Band Communication Systems
- Radar Systems
- Sub-assemblies

Electrical Specifications:

Parameter	Minimum	Typical	Maximum
Passband Frequency	69 GHz		71 GHz
Passband Insertion Loss		1.5 dB	2.5 dB
Passband Ripple		±0.3 dB	
Rejection Frequency, Low Side	DC		66 GHz
Rejection Frequency, High Side	74 GHz		90 GHz
Rejection		40 dB	
Passband Return Loss		14 dB	
Specification Temperature		+25°C	
Operating Temperature	-40°C		+85°C

Mechanical Specifications:

Item	Specification
Waveguide	WR-12 Waveguide with UG-387/U Flange
Material	Aluminum
Finish	Gold Plated
Weight	0.4 Oz
Size	1.20" (L) X 0.75" (Ø)
Outline	WF-BE





Waveguide Bandpass Filter, E Band, 69 to 71 GHz

Typical Insertion Loss vs. Frequency

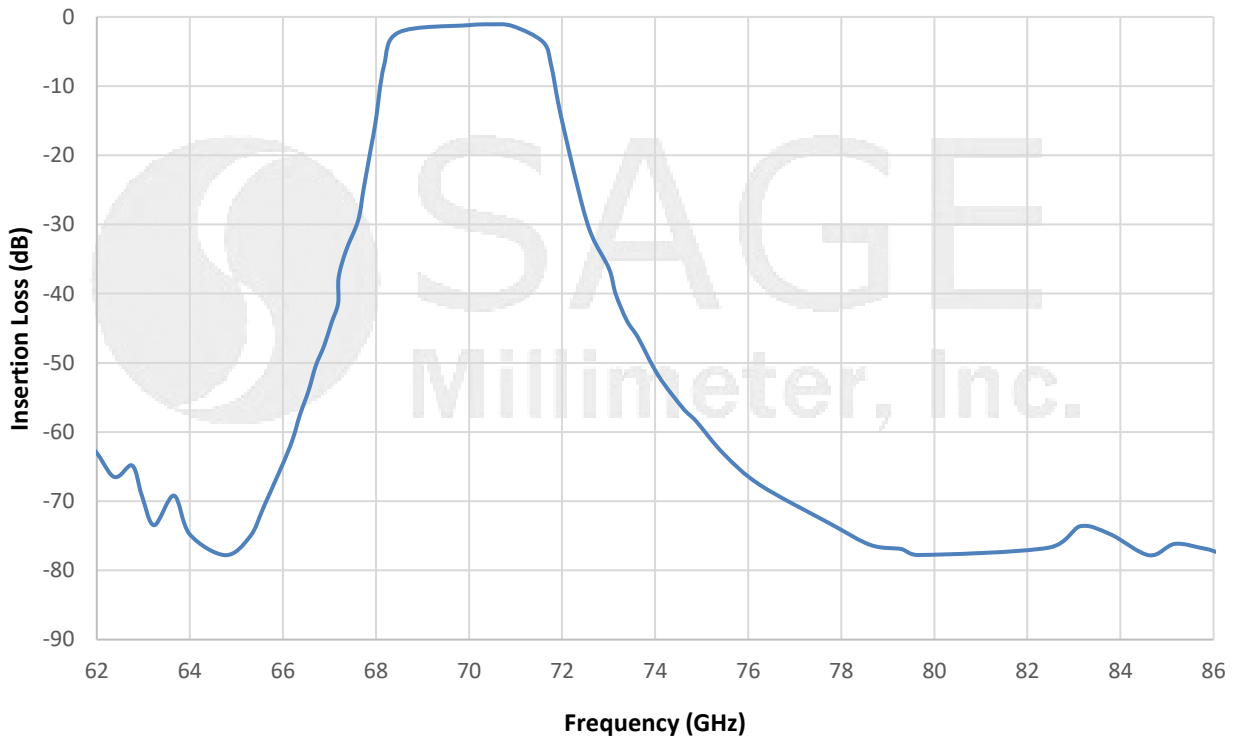

Mechanical Outline: (Unless otherwise specified, all dimensions are in inches [millimeters])

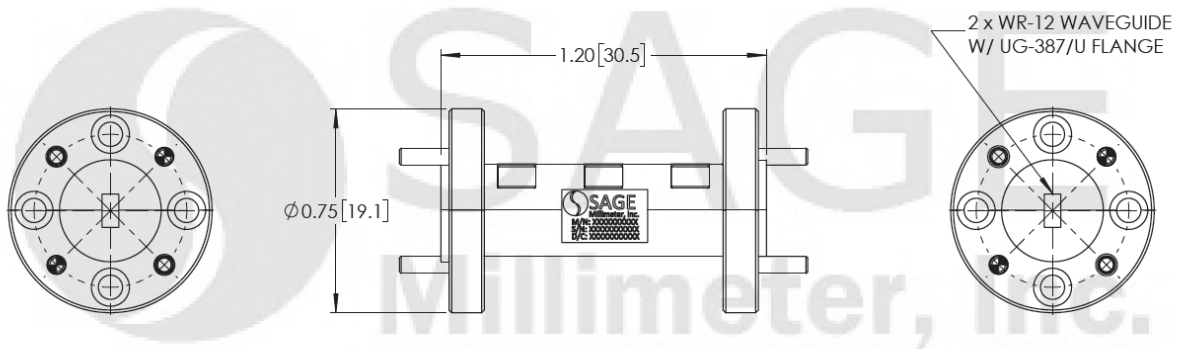

Note:

- All data presented is collected from a sample lot. Actual data may vary unit to unit, slightly.
- All testing was performed under +25 °C case temperature.
- SAGE Millimeter, Inc. reserves the right to change the information presented without notice.

Caution:

- Any foreign objects in the waveguide will degrade performance and/or damage the device.



www.sagemillimeter.com | 3043 Kashiwa Street, Torrance, CA 90505
 Phone: 424-757-0168 | Fax: 424-757-0188 | Email: sales@sagemillimeter.com