



F-Band Micrometer Driven Phase Shifter

Description:

Model STP-18-08-M2 is a F Band micrometer driven phase shifter that covers the frequency range of 90 to 140 GHz. The phase shifter has a micrometer dial which allows for repeatable phase shift settings. The phase shifter is an ideal piece of equipment in waveguide systems where broadband phase shifting is required. The phase shifter exhibits a 1.0 dB typical insertion loss and an adjustable phase range of up to 180 degrees.



Features:

- Full Band Coverage
- Low Cost
- Convenient Mechanical Setting

Applications:

- Test Lab
- Instrumentations
- Manual Test Set

Electrical Specifications:

Parameter	Minimum	Typical	Maximum
RF Frequency Range	90 GHz		140 GHz
Insertion Loss		1.0 dB	
Phase Shifting Range	0 to 180°		
VSWR		1.3:1	
Power Handling		400 mW	500 mW
Specification Temperature		+25°C	
Operating Temperature	-40°C		+85°C

Mechanical Specifications:

Item	Specification
RF Input	WR-08 Waveguide with UG-387/U-M Flange
RF Output	WR-08 Waveguide with UG-387/U-M Flange
Setting	Micrometer Head
Insertion Length	2.5"
Flange Material	Brass
Finish	Gold Plated Waveguide Faces; Black Painted Body
Weight	4.0 Oz
Outline	TP-MF-BX1





F-Band Micrometer Driven Phase Shifter

Mechanical Outline: (Unless otherwise specified, all dimensions are in inches [millimeters].)

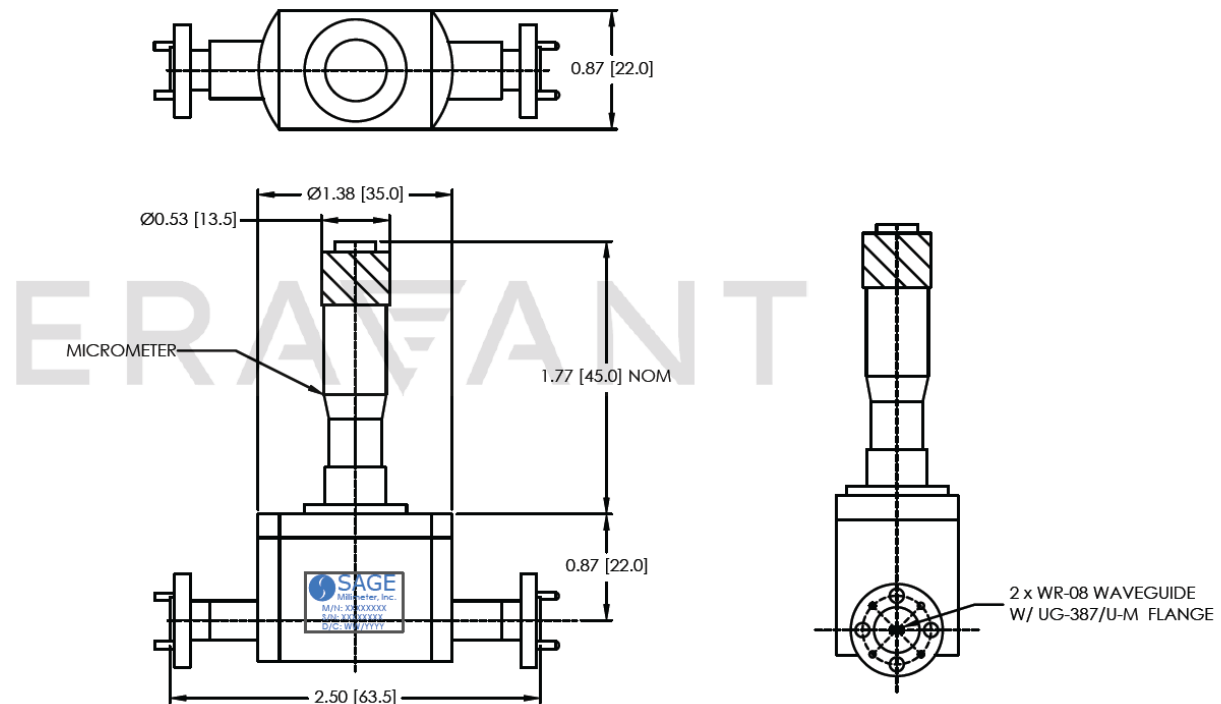

Note:

- Eravant reserves the right to change the information presented without notice.

Caution:

- Exceeding absolute maximum ratings shown will damage the device.
- Any foreign objects in the waveguide will cause performance degradation and may damage the device.

