

STO-1920305-R-E1

WR-19 VNA Frequency Extender, Receiver (Rx) Module, 10 to 15 GHz Input

STO-1920305-R-E1 is a compact coaxial vector network analyzer (VNA) frequency extender receiver (RX) module that extends lower frequency VNA signals to 40 to 60 GHz. It is compatible with modern vector network analyzers such as Rohde & Schwarz ZNA, Anritsu VectorStar™, Keysight PNA-X Series, and Copper Mountain CobaltFx. The VNA needs dual sources to be extended. This frequency extender can be used to measure one-path transmission (S21 or S12) through DUT when paired with compatible transmitter. When Rx module is paired with Tx/Rx module, the setup can be used to measure reflection at input of DUT and transmission through DUT. An AC to DC Power adapter is included. The Eravant calibration kit (**STQ-TO-19-S1-CKIT1**) and **Wave-Glide™ Rail System (STQ-TL-RW-S10-M1)** are highly recommended to complete the coaxial VNA test set. VNA extender is packaged individually in a rugged equipment box with additional hardware and tools.



Electrical Specifications:

Parameter	Minimum	Typical	Maximum
Frequency Range	40 GHz		60 GHz
Test Port Input Power (Damage)*			+20 dBm
Dynamic Range** @ 10 Hz BW	100 dB	120 dB	
Test Port Match		10 dB	
LO Source Input Frequency (RF±IF)	10 GHz		15 GHz
LO Source Input Power	-6 dBm	-3 dBm	0 dBm
IF Frequency Range	10 MHz		1000 MHz
Multiplication Factor		4	
Specification Temperature	+20°C		+30°C
Operating Temperature	0°C		+50°C

*Max input power is specified when attenuation level is minimum. Increasing attenuation level will increase power handling.

**Measured with compatible Tx/Ref or Tx/Rx module.

ECCN

EAR99

FEATURES

- Full Band Coverage
- Dynamic Range of 120 dB
- AC Power Input: 100 to 240 VAC

APPLICATIONS

- VNA Frequency Extension
- OTA Measurements
- Test Lab Instrumentation

Recommended Pairing

- Cal Kit: [STQ-TO-19-S1-CKIT1](#)
- [Waveguide-Glide™ Rail System](#)
- Cable: [SCW-SMSM040-F1-A-PM](#)

Recommended Pairing

- [VNA Extender Configuration Guide](#)
- [VNA Extenders and Cal Kits](#)



STO-1920305-R-E1

Mechanical Specifications:

Item	Specification
Test Port	WR-19 Waveguide with UG-383/U-M Anti-Cocking Flange
LO Source Input Ports	SMA (F)
IF Measure Port	SMA (F)
DC Power Receptacle	LEMO EGG.0B.304.CLL
Finish	Black Anodized
Weight (Per Module)	2.1 lbs.
Size (Without Adjustable Feet)	5.00" (L) x 3.75" (W) x 2.20" (H)
Outline	TO-RU-A

Included Components:

Item	Eravant Model Number	Quantity
SMA Connector Torque Wrench	SCH-08008-S1	1
AC-to-DC Power Adapter	STU-110006005-HF	1

Connecting Cables are not included. Eravant coaxial cable, model [SCW-SMSM040-F1-A-PM](#), is highly recommended. Four (4) cables are required to connect this module with VNA

MAKING MILLIMETERWAVE ACCESSIBLE

Simplified Block Diagram

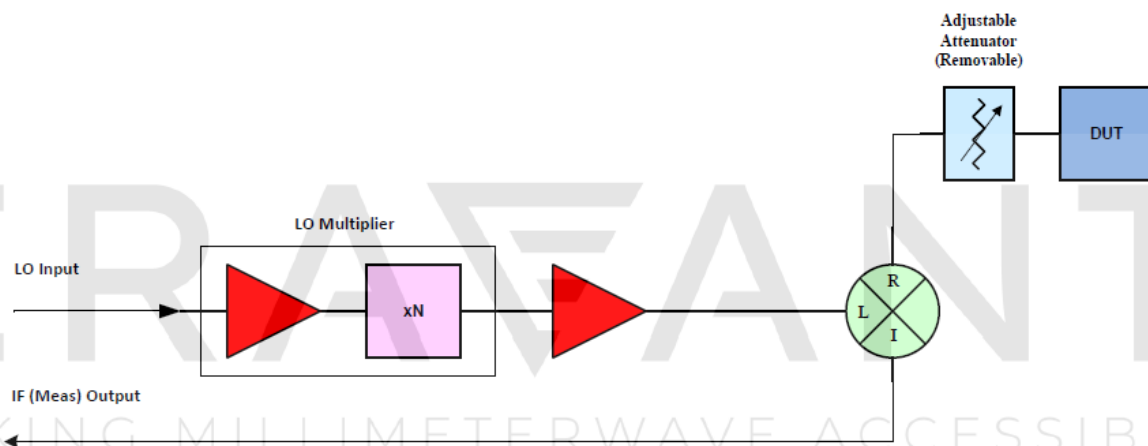

ERAVANT
MAKING MILLIMETERWAVE ACCESSIBLE

STO-1920305-R-E1

Mechanical Outline: (Unless otherwise specified, all dimensions are in inches [millimeters])

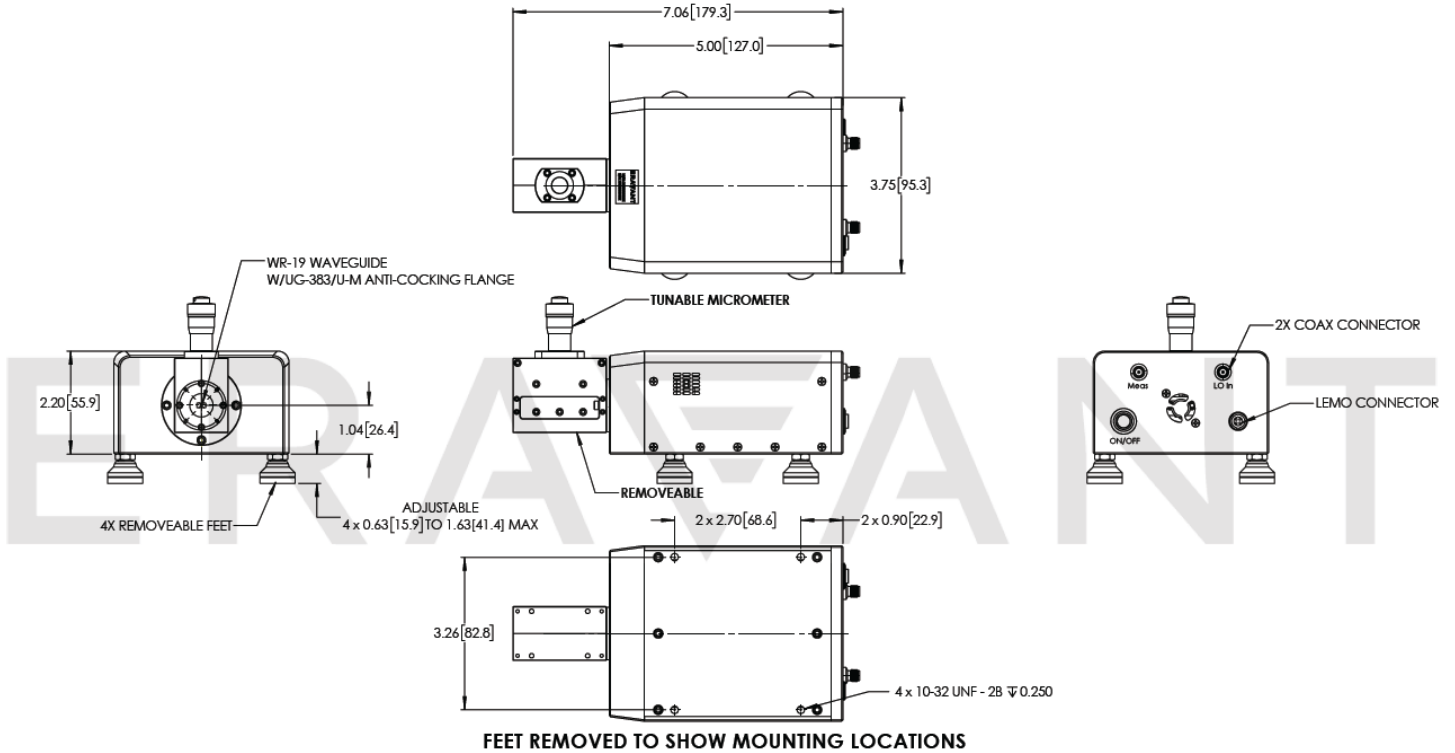

NOTE:

- To complete a frequency extender test set, pair this Rx module with a compatible Tx/Ref or Tx/Rx module listed in [VNA Frequency Extenders](#) page.
- Eravant reserves the right to change the information presented without notice.

CAUTION:

- Exceeding absolute maximum ratings shown will damage the extenders.
- Any foreign objects in the waveguide will cause performance degradation or damage the device.
- For 1.35 mm, 1.85 mm, 2.4 mm, 2.92 mm, and SMA connectors proper torque should be applied: 8.0 ± 0.15 inch-pounds (0.90 ± 0.02 Nm). Torque wrench model [SCH-08008-S1](#) is highly recommended.