

STO-1020307-C-E2

W-Band ACCESS VNA Frequency Extender, 20 GHz Tx/Rx Module

STO-1020307-C-E2 is a W-Band vector network analyzer (VNA) frequency extender Tx/Rx designed to achieve full 2-port S-parameter testing at 67 to 116 GHz. It is compatible with modern vector network analyzers such as the Rohde & Schwarz ZNA, Anritsu VectorStar™, Keysight PNA-X Series, and Copper Mountain CobaltFx. The VNA needs dual sources to be extended. The frequency extender can achieve a dynamic range up to 120 dB for certain passive products that require high rejection, isolation, and return loss testing such as directional couplers, orthomode transducers, and filters. An AC to DC Power adapter and two **Proxi-Flange™ Contactless Flanges (STQ-WG-10010-FB-CF and STQ-WG-10025-FB-CF)**, are included. The **Eravant Calibration Kit (STQ-TO-10-S1-CKIT1)** and **Wave-Glide™ Rail System (STQ-TL-RW-S10-M1)** are highly recommended to complete the W-Band VNA test. VNA extender is packaged individually in a rugged equipment box with additional hardware and tools.



Electrical Specifications:

Parameter		Minimum	Typical	Maximum
Frequency Range	Standard	75 GHz		110 GHz
	Extended	67 GHz		116 GHz
Test Port Output Power (No Attenuation)			+7 dBm	
Test Port Input Power (Damage)				+30 dBm
Dynamic Range @ 10 Hz BW	Standard	100 dB	120 dB	
	Extended		95 dB	
Test Port Match			25 dB	
Directivity			30 dB	
RF Source Input Frequency		11.16 GHz		19.33 GHz
RF Source Input Power		-3 dBm	0 dBm	+6 dBm
LO Source Input Frequency		11.16 GHz		19.33 GHz
LO Source Input Power		0 dBm	+3 dBm	+6 dBm
IF Frequency Range		10 MHz		1000 MHz
Multiplication Factor			6	
Magnitude Stability @ 300 Hz BW			±0.3 dB	
Phase Stability @ 300 Hz BW			±2°	
Specification Temperature		+20°C		+30°C
Operating Temperature		0°C		+50°C

ECCN

3A001.b.7

FEATURES

- 67-116 GHz Coverage
- Dynamic Range of 120 dB
- AC Power Input: 100 to 240 VAC

APPLICATIONS

- VNA Frequency Extension
- S-Parameter Characterization
- Test Lab Instrumentation

RECOMMENDED PAIRINGS

- Cal Kit: [STQ-TO-10-S1-CKIT1](#)
- [Wave-Glide™ Rail System](#)
- [Waveguide Quick Connects](#)
- Cable: [SCW-SMSM040-F1-A-PM](#)

RECOMMENDED RESOURCES

- [Contactless WG Flange & mmWTHz](#)
- [Test Setup Applications](#)
- [VNA Extender Configuration](#)



STO-1020307-C-E2

Mechanical Specifications:

Item	Specification
Test Port	WR-10 Waveguide with UG-387/U-M Precision Anti-Cocking Flange
RF and LO Source Input Ports	SMA (F), SMA (F)
IF Output Port	SMA (F)
IF Reference Port	SMA (F)
DC Power Receptacle	LEMO EGG.0B.304.CLL
Finish	Black Anodized
Weight (Per Module)	4.4 lb
Size (Without Adjustable Feet)	8.00" (L) x 3.00" (W) x 1.90" (H)
Outline	TO-SW-A-2

Components Included:

Item	Eravant Model Number	Quantity
Proxi-Flange™ Contactless Flange, 1.0" Long	STQ-WG-10010-FB-CF	1
Proxi-Flange™ Contactless Flange, 2.5" Long	STQ-WG-10025-FB-CF	1
Waveguide Screws, 3/32 Hex Head	SWH-332-SS-10	1 (10 Screws Total)
Waveguide Screwdriver, 3/32 Hex Head	SWH-332-DS	1
SMA Connector Torque Wrench	SCH-08008-S1	1
AC-to-DC Power Adapter	STU-110006005-HF	1

Connecting cables are not included. Eravant coaxial cable, model **SCW-SMSM040-F1-A-PM**, is highly recommended. A total of four (4) are required for full operation.

Simplified Block Diagram:

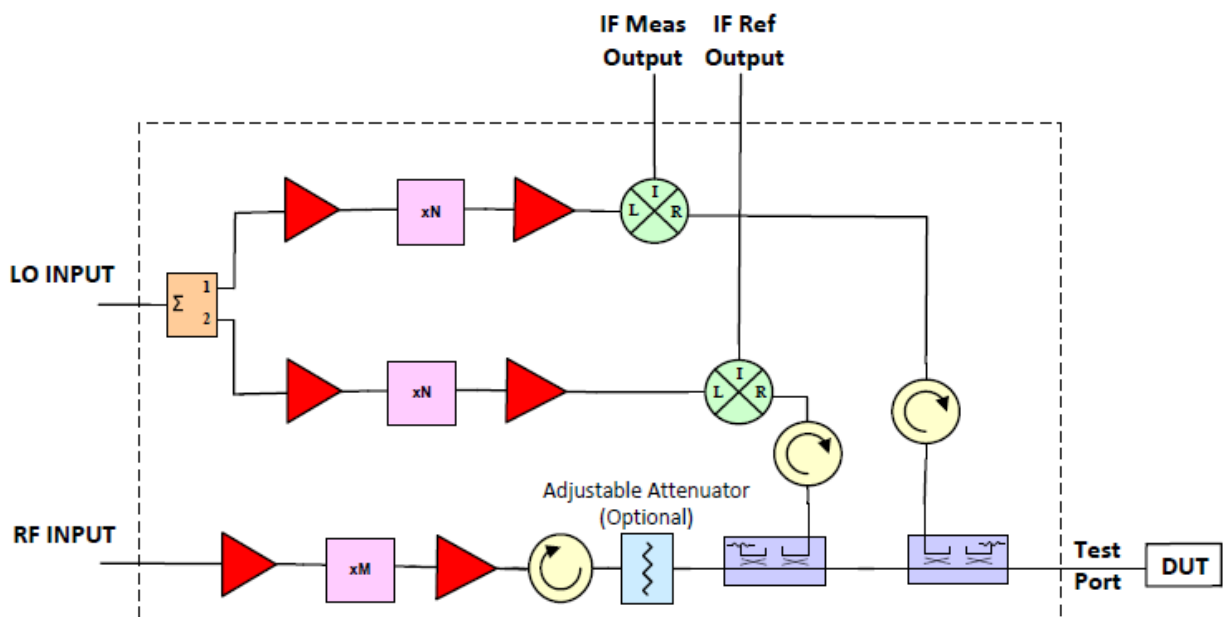

Dynamic Range vs. Frequency

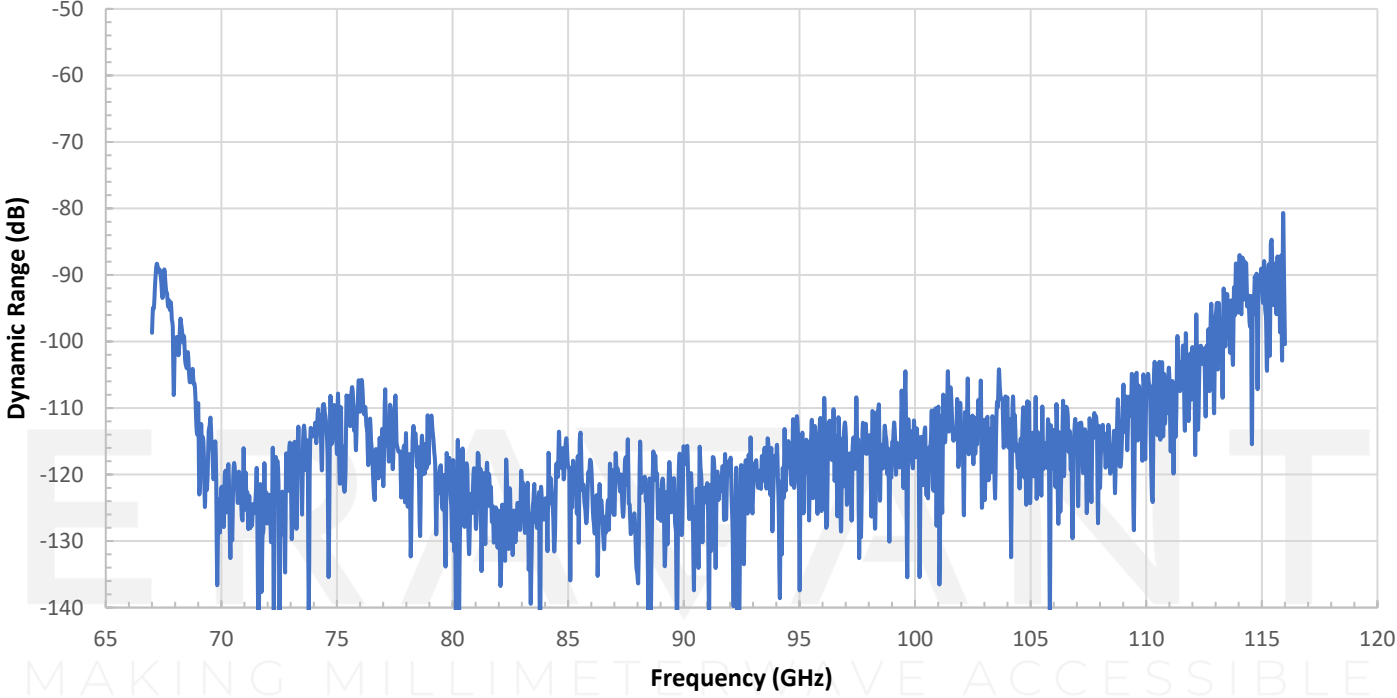

Directivity vs. Frequency

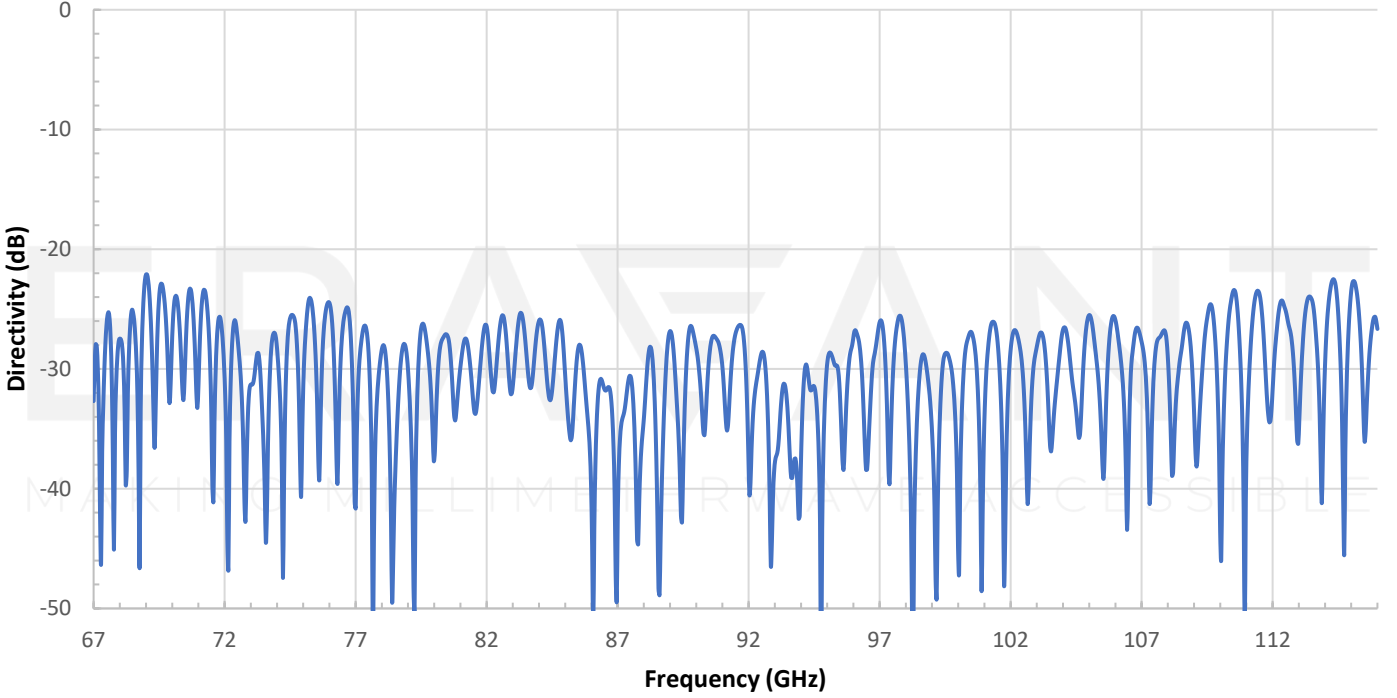

Test Port Match vs. Frequency

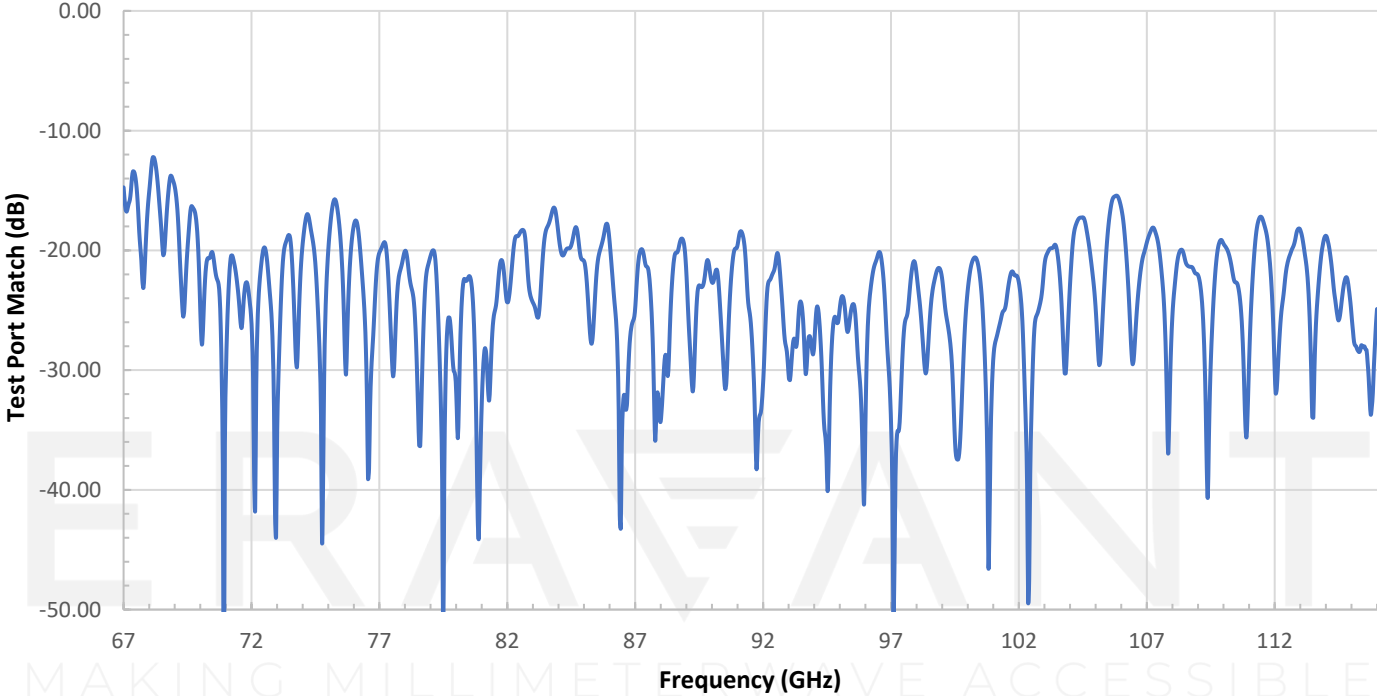

Output Power vs. Frequency

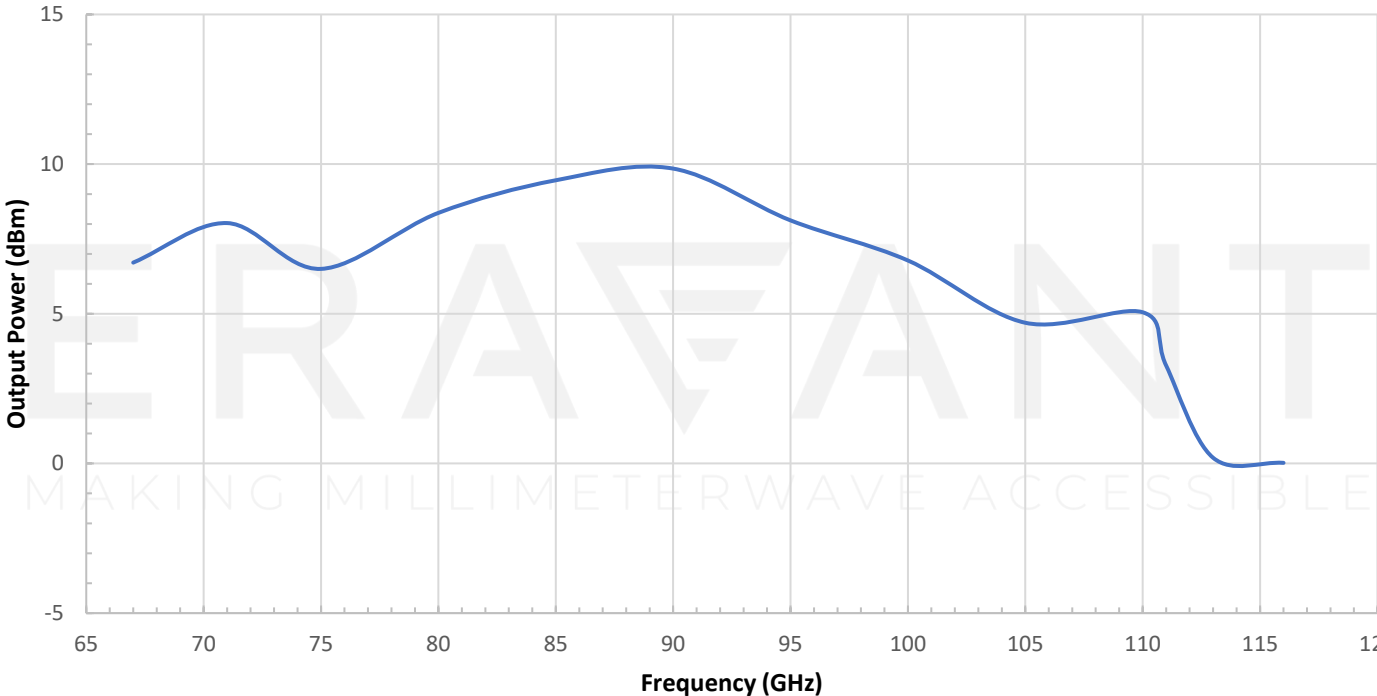

STO-1020307-C-E2

Mechanical Outline: (Unless otherwise specified, all dimensions are in inches [millimeters])
TO-SW-A-2

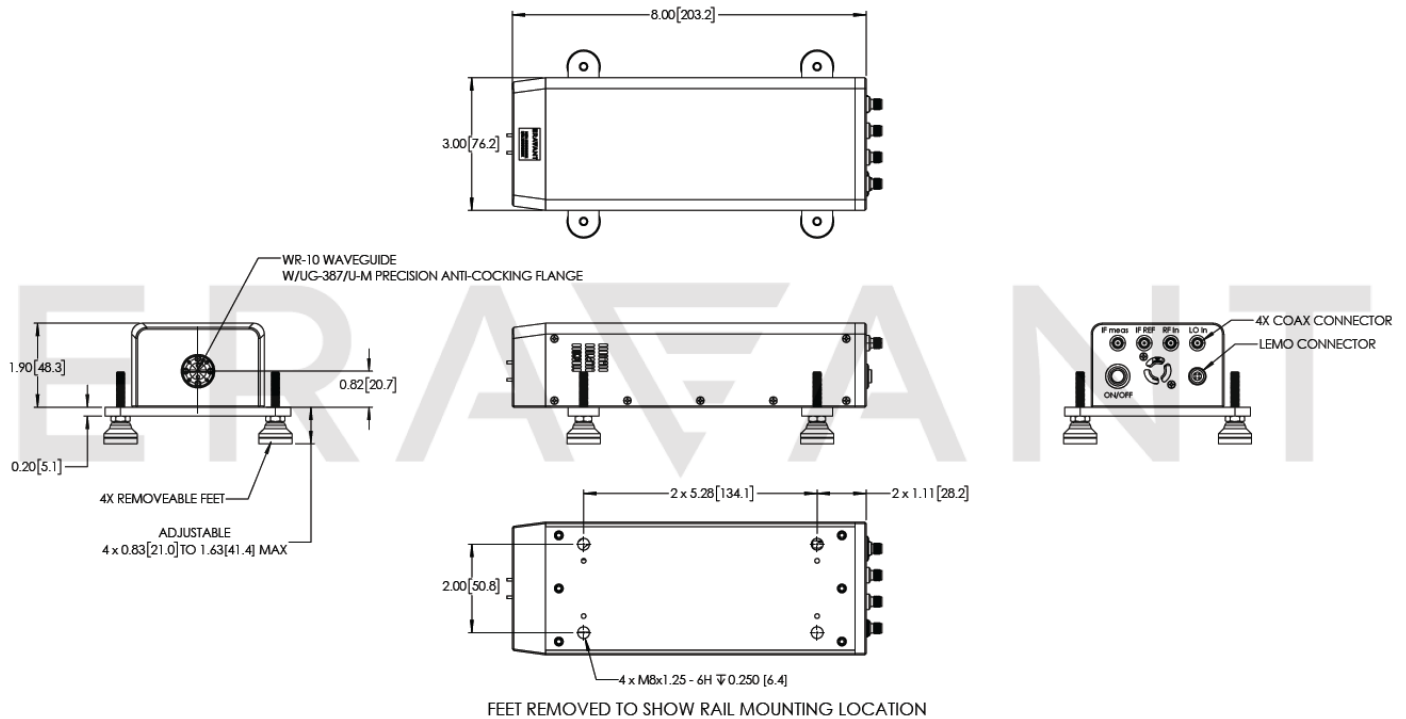

NOTE:

- Only one extender module is included in STO-1020307-C-E2: Tx/Rx module. A pair of extenders is offered under a different model number and can be found on our [VNA Frequency Extenders](#) page.
- It is **recommended** that calibration be performed every 12 months to ensure proper operation.
- Eravant reserves the right to change the information presented without notice.
- Extended frequency band operation will have specifications degradation outside the nominal frequency range. Please consult the provided data plots for more information.

CAUTION:

- Exceeding absolute maximum ratings of the device will damage the extenders.
- For 1.35 mm, 1.85 mm, 2.4 mm, 2.92 mm, and SMA connectors proper torque should be applied: 8.0 ± 0.15 inch-pounds (0.90 ± 0.02 Nm). Torque wrench model [SCH-08008-S1](#) is highly recommended.
- Any foreign objects in the waveguide will cause performance degradation or damage the device.