

STO-1009305-R-E1

W-Band VNA Frequency Extender

Receive (Rx) Module, 6.25 to 9.17 GHz Input

STO-1009305-R-E1 is a compact W-Band vector network analyzer (VNA) frequency extender receive (Rx) module that extends lower frequency VNA signals to 75 to 110 GHz. It is compatible with modern vector network analyzers such as Rohde & Schwarz ZNA, Anritsu VectorStar™, Keysight PNA-X Series, and Copper Mountain CobaltFx. The VNA needs dual sources to be extended. This frequency extender can be used to measure one-path transmission (S21 or S12) through DUT when paired with compatible transmitter. When Rx module is paired with Tx/Rx module, the setup can be used to measure reflection at input of DUT and transmission through DUT. An AC to DC Power adapter and a **Proxi-Flange™ Contactless Flange (STQ-WG-10025-FB-CF)**, are included. The Eravant calibration kit (**STQ-TO-10-S1-CKIT1**) and **Wave-Glide™ Rail System (STQ-TL-RW-S10-M1)** are highly recommended to complete the W-Band VNA test set. VNA extender is packaged individually in a rugged equipment box with additional hardware and tools.



Electrical Specifications

Parameter	Minimum	Typical	Maximum
Frequency Range	75 GHz		110 GHz
Input Attenuation Control Range		30 dB	
Test Port Input Power (Damage)*			+10 dBm
Dynamic Range** @ 10 Hz BW	100 dB	120 dB	
Test Port Match		20 dB	
LO Source Input Frequency (RF±IF)	6.25 GHz		9.17 GHz
LO Source Input Power	-6 dBm	-3 dBm	0 dBm
IF Frequency Range	10 MHz		1000 MHz
Multiplication Factor		12	
Specification Temperature	+20 °C		+30 °C
Operating Temperature	0 °C		+50 °C

*Max input power is specified when attenuation level is minimum. Increasing attenuation level will increase power handling.

**Measured with compatible Tx/Ref or Tx/Rx module.

ECCN

- 3A001.b.7

FEATURES

- Full Band Coverage
- Dynamic Range of 1000 dB
- AC Power Input: 100 to 240 VAC

APPLICATIONS

- VNA Frequency Extension
- OTA Measurements
- Test Lab Instrumentation

RECOMMENDED PAIRINGS

- Cal Kit: [STQ-TO-10-S1-CKIT1](#)
- [Waveguide Quick Connects](#)
- Cable: [SCW-SMSM040-F1-A-PM](#)

RECOMMENDED RESOURCES

- [Contactless WG Flange & mmW-THz Test Setup Applications](#)
- [VNA Extender Configuration Guide](#)
- [VNA Extenders & Cal Kits](#)



STO-1009305-R-E1

Mechanical Specifications

Item	Specification
Test Port	WR-10 Waveguide with UG-387/U-M Precision Anti-Cocking Flange
LO Source Input Port	SMA (F)
IF Measure Port	SMA (F)
DC Power Receptacle	LEMO EGG.0B.304.CLL
Finish	Black Anodized
Weight (per Module)	2.1 lbs.
Size (Without Adjustable Feet)	5.00" (L) x 3.75" (W) x 1.90" (H) [Without Attenuator] 6.26" (L) x 3.75" (W) x 1.90" (H) [With Attenuator]
Outline	TO-RW-A

Included Components:

Item	Eravant Model Number	Quantity
Proxi-Flange™ Contactless Flange, 2.5" Long	STQ-WG-10025-FB-CF	1
Waveguide Screws, 3/32 Hex Head	SWH-332-SS-10	1 (10 Screws Total)
Waveguide Screwdriver, 3/32 Hex Head	SWH-332-DS	1
SMA Connector Torque Wrench	SCH-08008-S1	1
AC-to-DC Power Adapter	STU-110006005-HF	1

Connecting cables are not included. Eravant coaxial cable, model [SCW-SMSM040-F1-A-PM](#), is highly recommended. Three (3) cables are required to connect this module with VNA.

Simplified Block Diagram

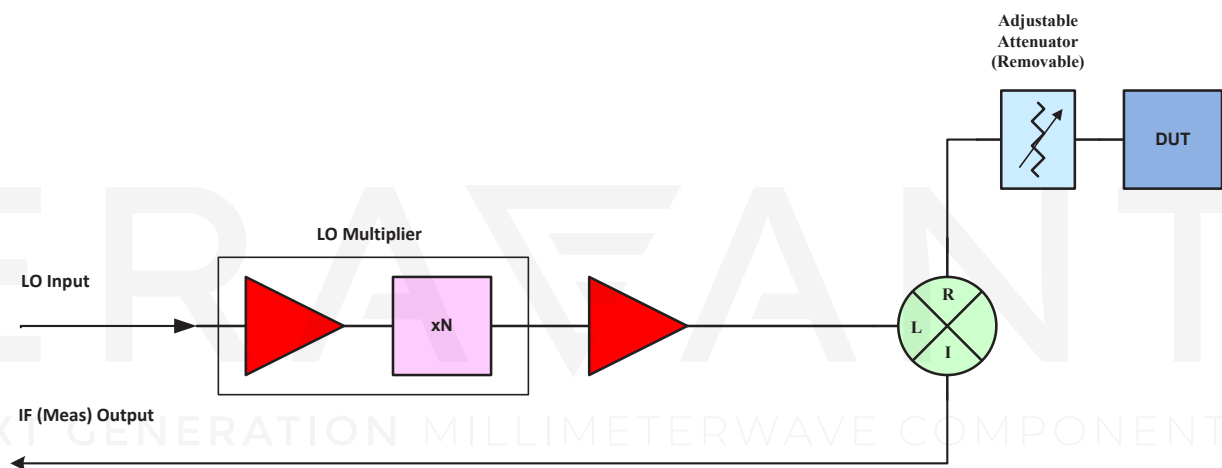

Dynamic Range vs. Frequency

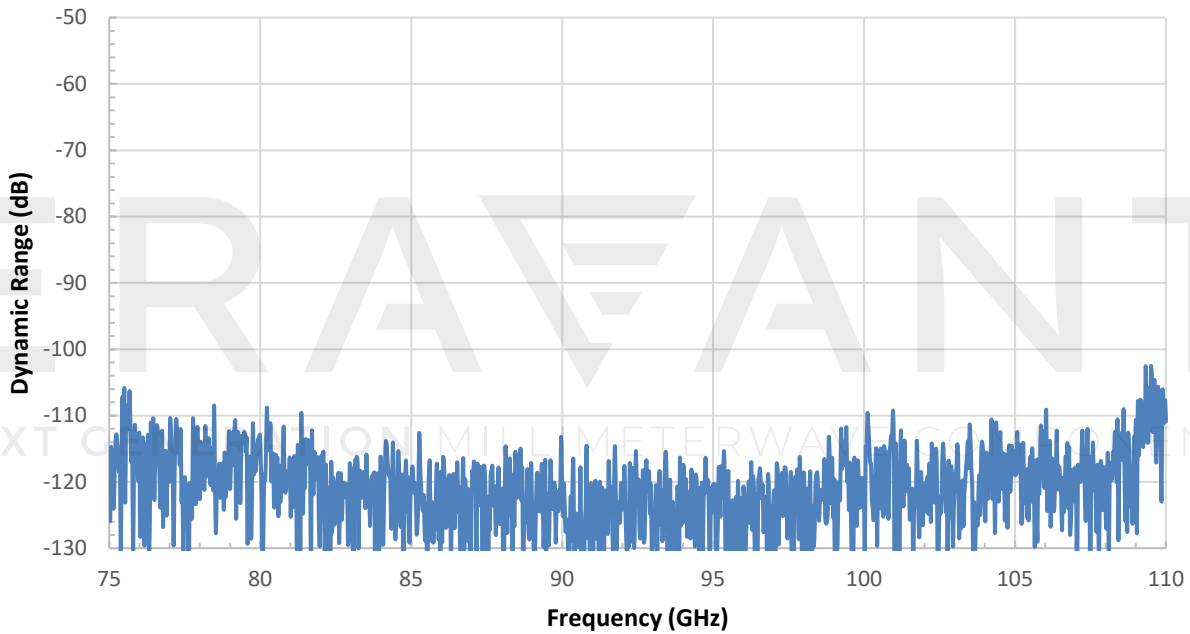

Mechanical Outline

Unless otherwise specified, all dimensions are in inches [millimeters]

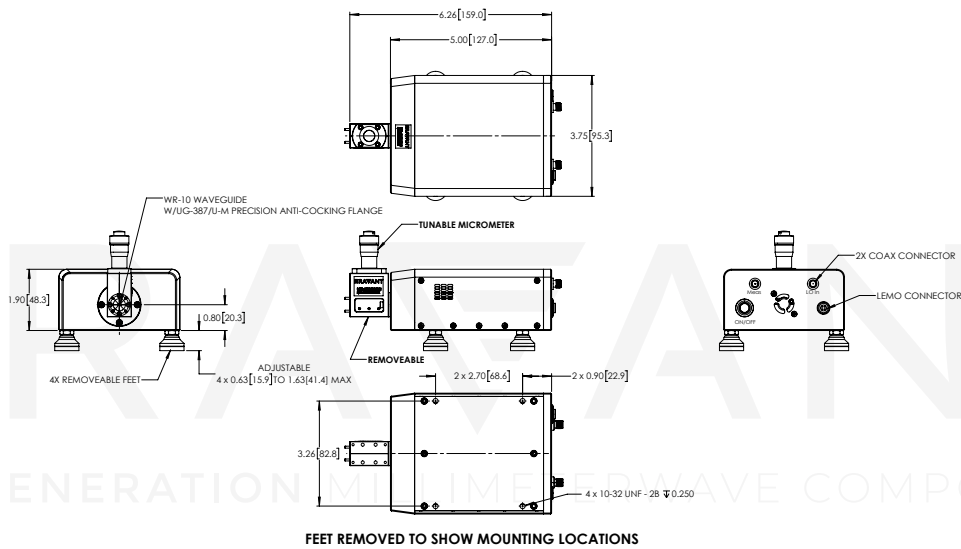

STO-1009305-R-E1

NOTE

- To complete a frequency extension set, pair this Rx module with a compatible Tx/Ref or Tx/Rx module listed in [VNA Frequency Extenders](#) page.
- Eravant reserves the right to change the information presented without notice.

CAUTION

- Exceeding absolute maximum ratings of the device will damage the extenders.
- Proper torque, 8.0 ± 0.15 inch-pounds (0.90 ± 0.02 Nm), should be applied. **Eravant torque wrench, model SCH-08008-S1, is highly recommended.**
- Any foreign objects in the waveguide will cause performance degradation or damage the device.

ERAVANT
NEXT GENERATION MILLIMETERWAVE COMPONENTSERAVANT
NEXT GENERATION MILLIMETERWAVE COMPONENTS