

Q-Band Spectrum Analyzer Harmonic Mixer, Common LO/IF Port

Description:

Model STH-22SF-S1 is a Q Band harmonic mixer employing single diode and broadband circuitry to deliver low conversion loss and continuous frequency coverage for full waveguide band operations covering the frequency range of 33 to 50 GHz. The mixer extends the operation frequency of test instruments like the spectrum analyzer and frequency counter from 18 GHz or below to full Q band operations. Unlike the balanced harmonic mixer, model number SFH-22SFSF-A3, the spectrum analyzer mixer does not have a built-in frequency diplexer. Therefore, their LO and IF ports are combined to a common coaxial port where their LO and IF signals are shared. This feature provides a convenient connection ability when used with the spectrum analyzer or frequency counter models that have a built-in diplexer, i.e., combined LO and IF port, such as the models offered by Advantest, Anritsu, Rohde & Schwarz, some Keysight models and Tektronix and National Instruments/Phase Matrix (EIP).



Features:

- Full Waveguide Coverage
- Combined LO and IF Port
- Instrumentation Grade

Applications:

- Phase Lock Loops
- Spectrum Analyzer with built-in Diplexer
- Frequency Counter with built-in Diplexer

Electrical Specifications:

Parameter	Minimum	Typical	Maximum
Frequency	33 GHz		50 GHz
IF Frequency	DC	1.0 GHz	4.0 GHz
LO Power	+10 dBm	+13 dBm	+16 dBm
Sensitivity		-90 dBm @ 1 KHz RBW	
RF Input Power		-20 dBm	+16 dBm
Specification Temperature		+25 °C	
Operating Temperature	0 °C		+50 °C

Mechanical Specifications:

Item	Specification
RF Port	WR-22 Waveguide with UG-383/U Flange
IF and LO Port	SMA (F)
Material	Aluminum
Finishing	Gold Plated
Weight	1.3 Oz
Outline	FD-Q1

Q-Band Spectrum Analyzer Harmonic Mixer, Common LO/IF Port

Mechanical Outline: (Unless otherwise specified, all dimensions are in inches)

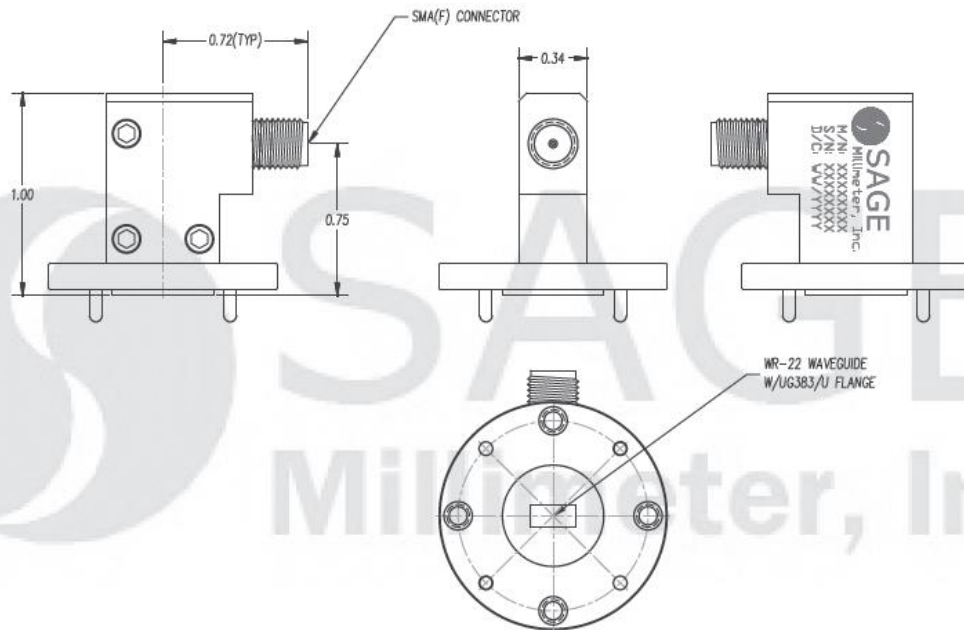

Note:

- SAGE Millimeter, Inc. reserves the right to change the information presented without notice.

Caution:

- Exceeding absolute maximum ratings of the mixer will damage the detector.
- The mixer is a static sensitive device. Always follow ESD rules when working with the mixer.
- Any foreign objects into the waveguide will lower performance and/or damage device.
- Proper torque, 8.0 ± 0.15 inch-pounds (0.92 ± 0.05 Nm), should be applied. **SAGE Millimeter torque wrench, model SCH-08008-S1, is highly recommended.**