

## STG-28-S1

### Ka-Band Noise Figure and Gain Test Extenders

**STG-28-S1** is a full Ka-Band noise figure and gain test extender that extends the noise and gain measurement capabilities of common and low frequency signal synthesizers and noise figure meters to the frequency range of 26.5 to 40 GHz. This extender is designed to interface with industry standard noise and gain test systems, such as the Keysight 8970A/B and Y Factor with a spectrum analyzer. It can also interface with most noise and gain analyzers in the 10 MHz to 1.6 GHz frequency range.



#### Electrical Specifications:

Parameter	Minimum	Typical	Maximum
RF Frequency	26.5 GHz		40.0 GHz
Noise Source ENR		18 dB	
Noise Source Bias Voltage/Current	+18 V <sub>DC</sub>	+28 V <sub>DC</sub> / 25 mA	+30 V <sub>DC</sub>
Down Converter IF Frequency	10.0 MHz	1 GHz	1.6 GHz
Down Converter LO Frequency	13.25 GHz		20.0 GHz
Down Converter LO Power		+3 dBm	+20 dBm
Down Converter RF Damage Level			+18 dBm
Down Converter Noise Figure		10 dB	
Down Converter Gain		20 dB	
Power Supply (AC Adapter Provided)	100 V <sub>AC</sub>		240 V <sub>AC</sub>
Specification Temperature		+25 °C	
Operating Temperature	0 °C		+50 °C

#### ECCN

EAR99

#### FEATURES

- Full Band Coverage
- Precision Calibrated ENR
- Great ENR and Gain Flatness

#### APPLICATIONS

- Test Lab
- Instrumentations

#### SUPPLEMENTAL DETAILS

MAKING MILLIMETERWAVE ACCESSIBLE



## STG-28-S1

### Mechanical Specifications:

Item	Specification
Noise Source RF Port	WR-28 Waveguide with UG-599/U Compatible Flange
Noise Source Bias Port	BNC (F)
Noise Source Trigger	SMA (F)
Down Converter RF Port	WR-28 Waveguide with UG-599/U Flange
Down Converter LO Port	SMA (F)
Down Converter IF Port	SMA (F)
Down Converter Bias Port	2.5 mm DC Jack (AC-to-DC power converter included)
Weight	4.0 lbs.
Outline	Down Converter (TC-A-2), Noise Source (TZ-OA-3)

### Block Diagram:

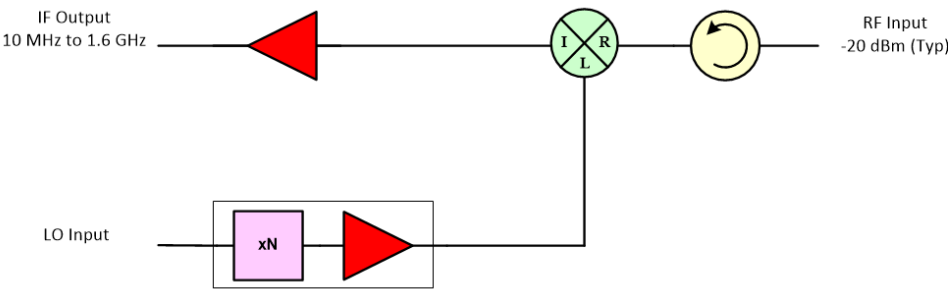

### Typical Conversion Gain vs. Frequency

RF = -20 dBm

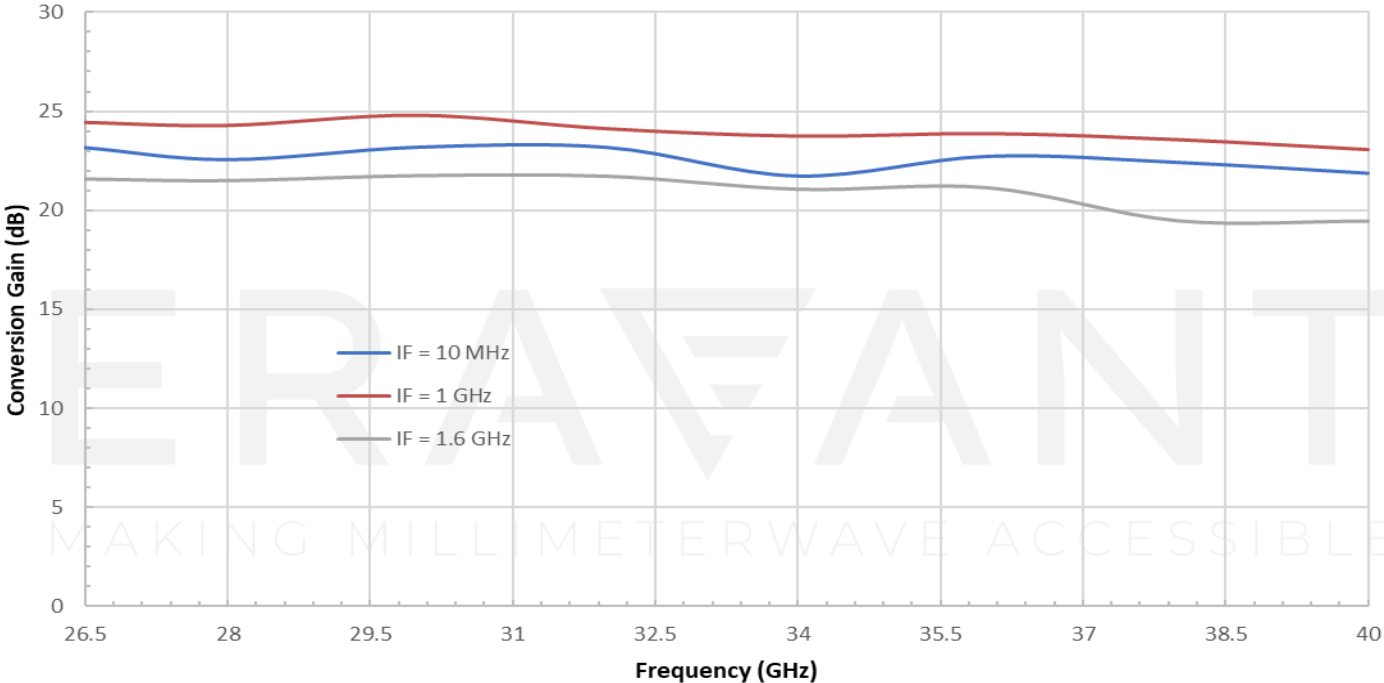

## STG-28-S1

### ENR vs. Frequency

Bias: +28 V<sub>DC</sub>/25 mA

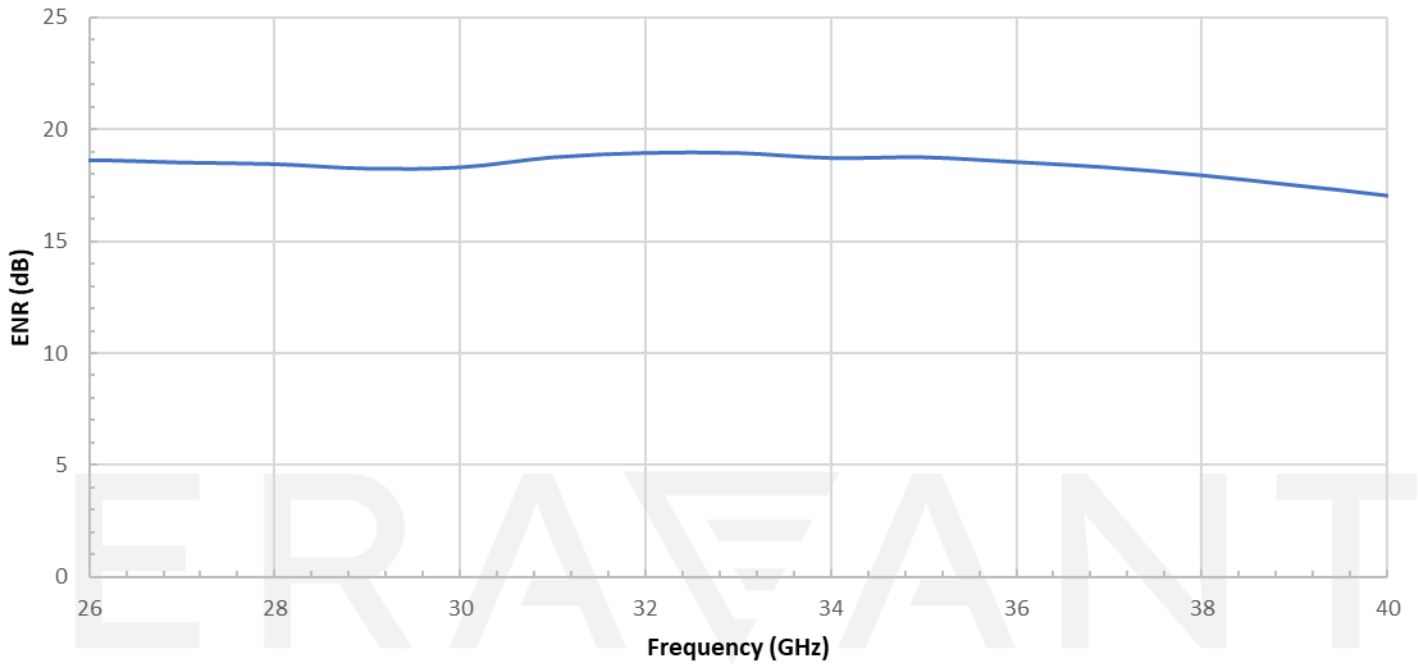

### Down Converter Mechanical Outline:

Unless otherwise specified, all dimensions are in inches [millimeters]

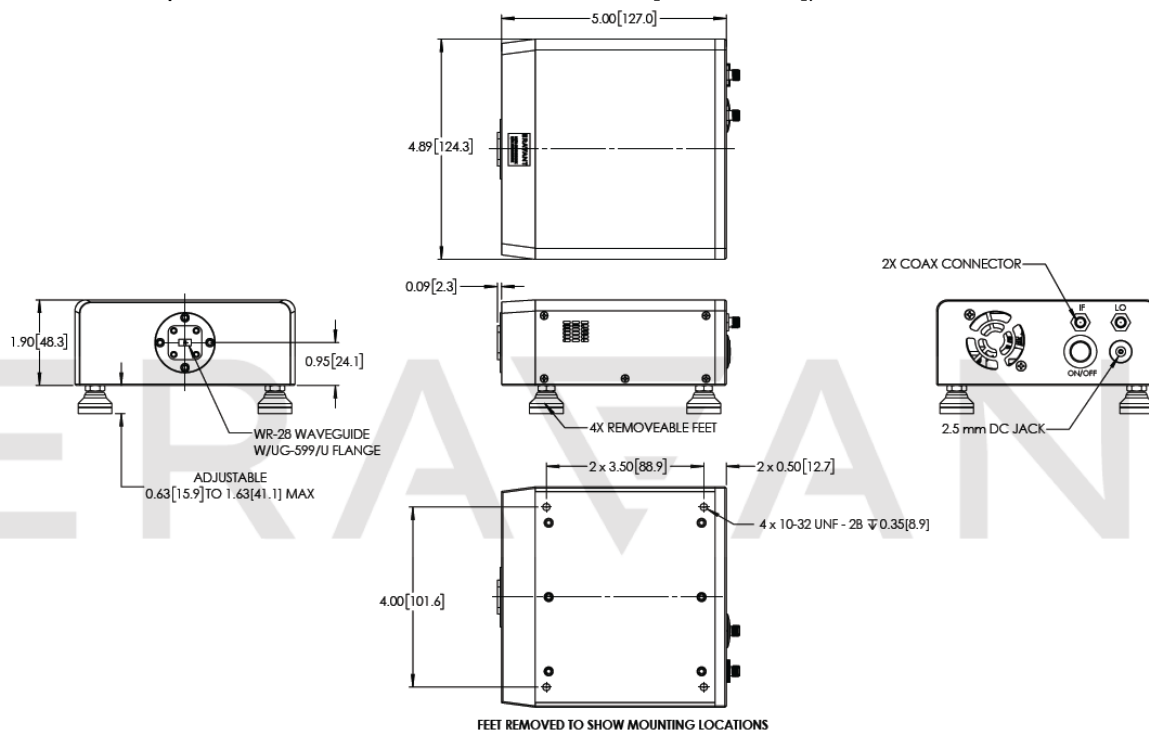

## STG-28-S1

### Noise Source Mechanical Outline:

Unless otherwise specified, all dimensions are in inches [millimeters]

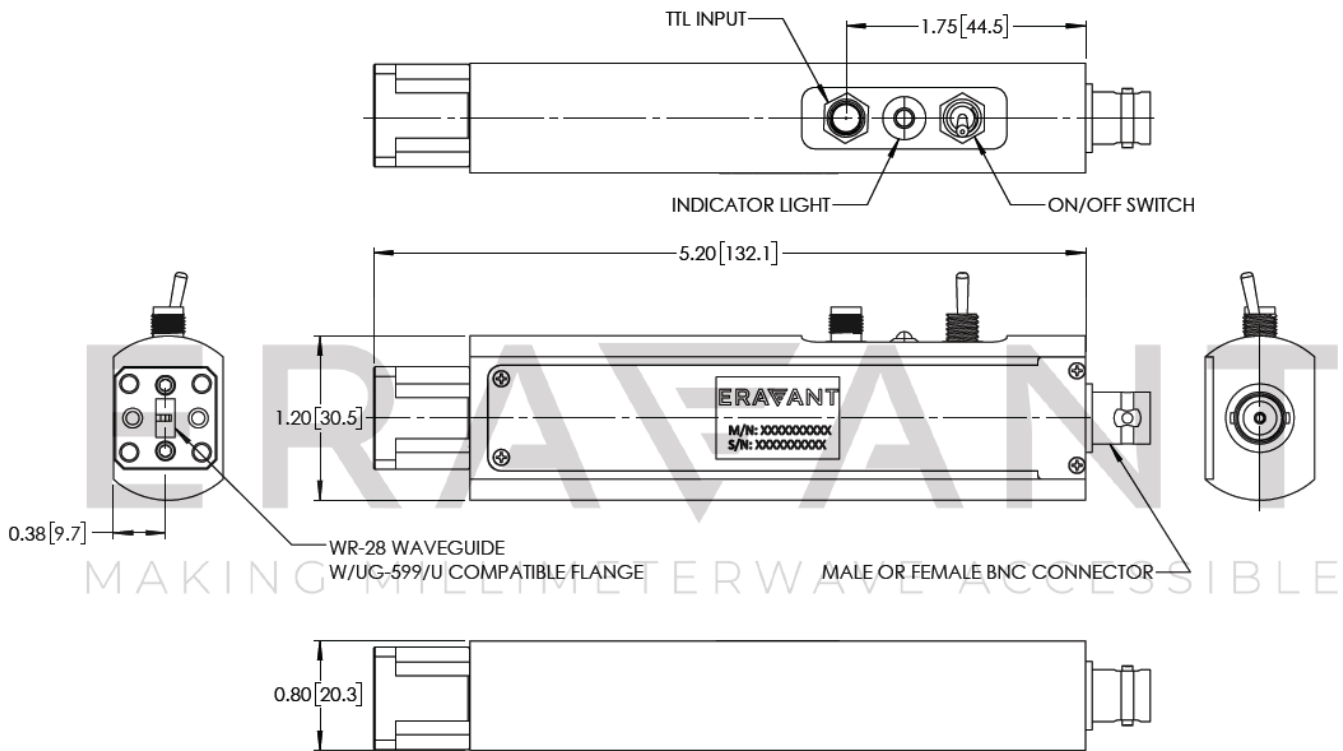

### NOTE:

- All data presented is collected from a sample lot. Actual data may vary unit to unit.
- All testing was performed under +25°C case temperature.
- The Triggering Port (female SMA connector) of the noise source is provided to turn the noise source on and off via a TTL control signal any time the Bias is applied. The switching frequency is limited to 1 KHz.
- The Power/Triggering Inversion Switch of the noise source is provided to manually turn the noise source on and off any time the Bias is applied. When the switch is in the "ON" position, the LED light will be illuminated.
- Eravant reserves the right to change the information presented without notice.

### CAUTION:

- Exceeding absolute maximum ratings shown will damage the device.
- Any foreign objects in the waveguide will cause performance degradation and possible device damage.