



W-Band X6 Frequency Extender, +15 dBm Output Power

Description:

Model STE-SF610-15-S1 is a high output power W-Band X6 frequency extender that uses an input frequency range of 12.5 to 18.33 GHz at +5 dBm along with harmonic generation and filtering to produce a 75 to 110 GHz RF signal at +15 dBm. The extender is designed and manufactured as a bench top unit to extend the low frequency synthesizer or sweeper without losing all of the functionalities and features. The extender also features adjustable legs, which can also be removed, to allow for an easy test set up.



Features:

- Full Waveguide Band Operation
- X6 Frequency Extension
- Low Harmonic Emission

Applications:

- Test Lab
- Network Analyzer Systems
- Automatic Test Set
- Antenna Range

Electrical Specifications:

Parameter	Minimum	Typical	Maximum
Output Frequency Range	75 GHz		110 GHz
Input Frequency Range	12.50 GHz		18.33 GHz
Output Power		+15 dBm	
Input Power	+1 dBm	+5 dBm	+20 dBm
Input Return Loss		10 dB	
Output Return Loss		15 dB	
Harmonic Suppression		20 dBc	
Spurious Suppression		60 dBc	
Voltage Input	+13 V	+15V/650mA	+16 V
Specification Temperature		+25 °C	
Operation Temperature	0 °C		+50 °C

Mechanical Specifications:

Item	Parameter
Input Port	SMA (F)
Output Port	WR-10 Waveguide with UG-387/U-M Flange
DC Bias	2.5 mm DC Jack (AC-to-DC power converter included)
DC Bias Switch	On-Off Rocker Switch with Indicator Light
Finish	Black Anodized
Weight	2 lb
Size	6.15" (W) x 6.89" (L) x 3.20" (H)
Outline	TE-W1



www.sagemillimeter.com | 3043 Kashiwa Street, Torrance, CA 90505
 Phone: 424-757-0168 | Fax: 424-757-0188 | Email: sales@sagemillimeter.com



W-Band X6 Frequency Extender, +15 dBm Output Power

Typical Output Power vs. Frequency

Bias: +15 V_{DC}/650 mA

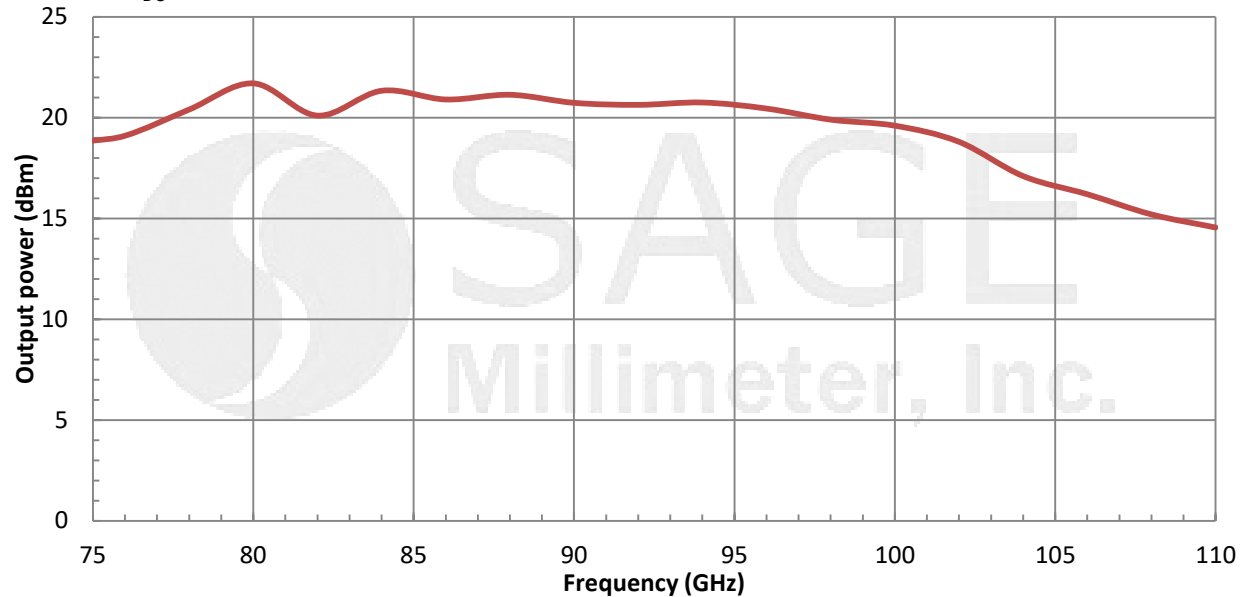

Mechanical Outline: (Unless otherwise specified, all dimensions are in inches [millimeters])

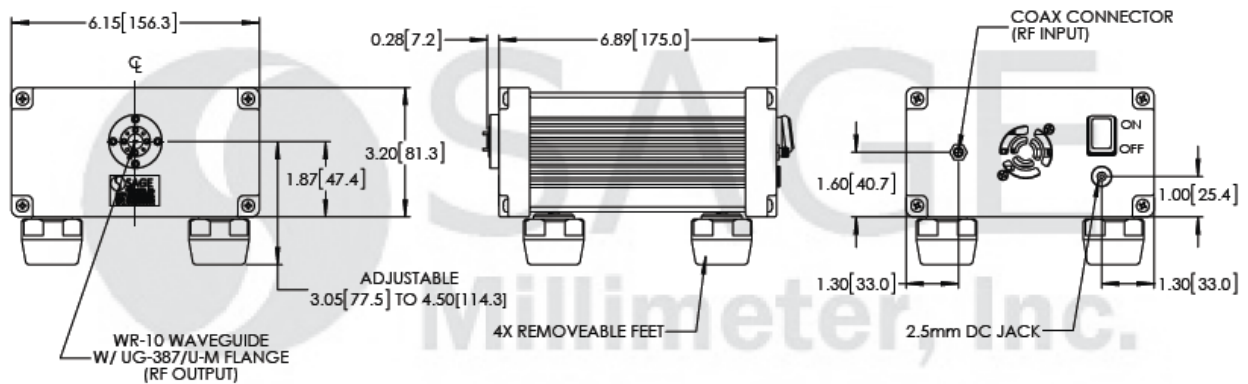

Note:

- All data presented is collected from a sample lot. Actual data may vary unit to unit.
- All testing was performed under +25°C case temperature.
- SAGE Millimeter, Inc. reserves the right to change the information presented without notice.

Caution:

- Exceeding absolute maximum ratings of the device will damage the device.
- Proper torque, 8.0 ± 0.15 inch-pounds (0.92 ± 0.05 Nm), should be applied. **SAGE Millimeter torque wrench, model SCH-08008-S1, is highly recommended.**
- Any foreign objects in the waveguide will cause performance degradation and may damage the device.



www.sagemillimeter.com | 3043 Kashiwa Street, Torrance, CA 90505
 Phone: 424-757-0168 | Fax: 424-757-0188 | Email: sales@sagemillimeter.com