

## STE-KF606-10-S1

### D-Band X6 High Power Frequency Extender

**STE-KF606-10-S1** is a D-Band X6 frequency extender that uses an input signal from 22.5 to 26.666 GHz at +5 dBm, along with filtering to produce a 135 to 160 GHz RF signal at +10 dBm. The extender is designed and manufactured as a bench top unit to extend the low frequency synthesizer or sweeper without losing functionalities and features. The extender also features adjustable legs, which can be removed, to allow for an easy test set up.



### Electrical Specifications:

Parameter	Minimum	Typical	Maximum
Output Frequency	135 GHz		160 GHz
Input Frequency	22.5 GHz		26.666 GHz
Output Power		+10 dBm	
Input Power		+5 dBm	
Input Damage Level			+20 dBm
Harmonic Suppression		15 dBc	
Spurious Suppression		60 dBc	
Voltage Input	+6 V <sub>DC</sub>	+8 V <sub>DC</sub>	+12 V <sub>DC</sub>
Bias Current		1,100 mA	
Specification Temperature		+25°C	
Operating Temperature	0°C		+50°C

### Mechanical Specifications:

Item	Specification
Input Port	K(F)
Output Port	WR-06 Waveguide with UG-387/U-M Flange
DC Bias Port	2.5 mm DC Jack (AC-to-DC power converter included)
Power Switch	On-Off Rocker Switch with Indicator Light
Finish	Black Anodized
Weight	6.6 lbs
Size	6.15" (W) x 6.89" (L) x 3.20" (H)
Outline	TE-D

### ECCN

3A001.b.7

### FEATURES

- X6 Frequency Extension
- Low Harmonic Content

### APPLICATIONS

- Test Lab
- Network Analyzer Systems
- Automatic Test Set
- Antenna Range

### SUPPLEMENTAL DETAILS



## STE-KF606-10-S1

### Typical Output Power vs. Frequency

RF Input: +5 dBm

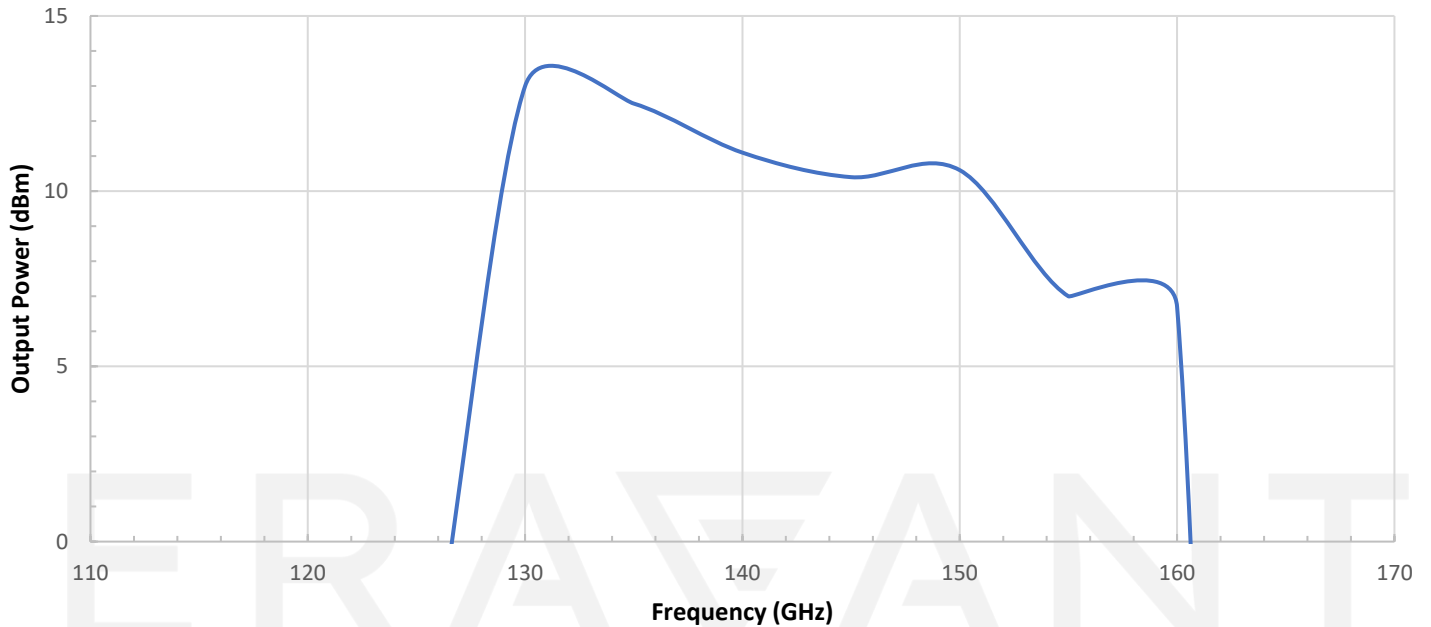

**Mechanical Outline:** (Unless otherwise specified, all dimensions are in inches [millimeters])

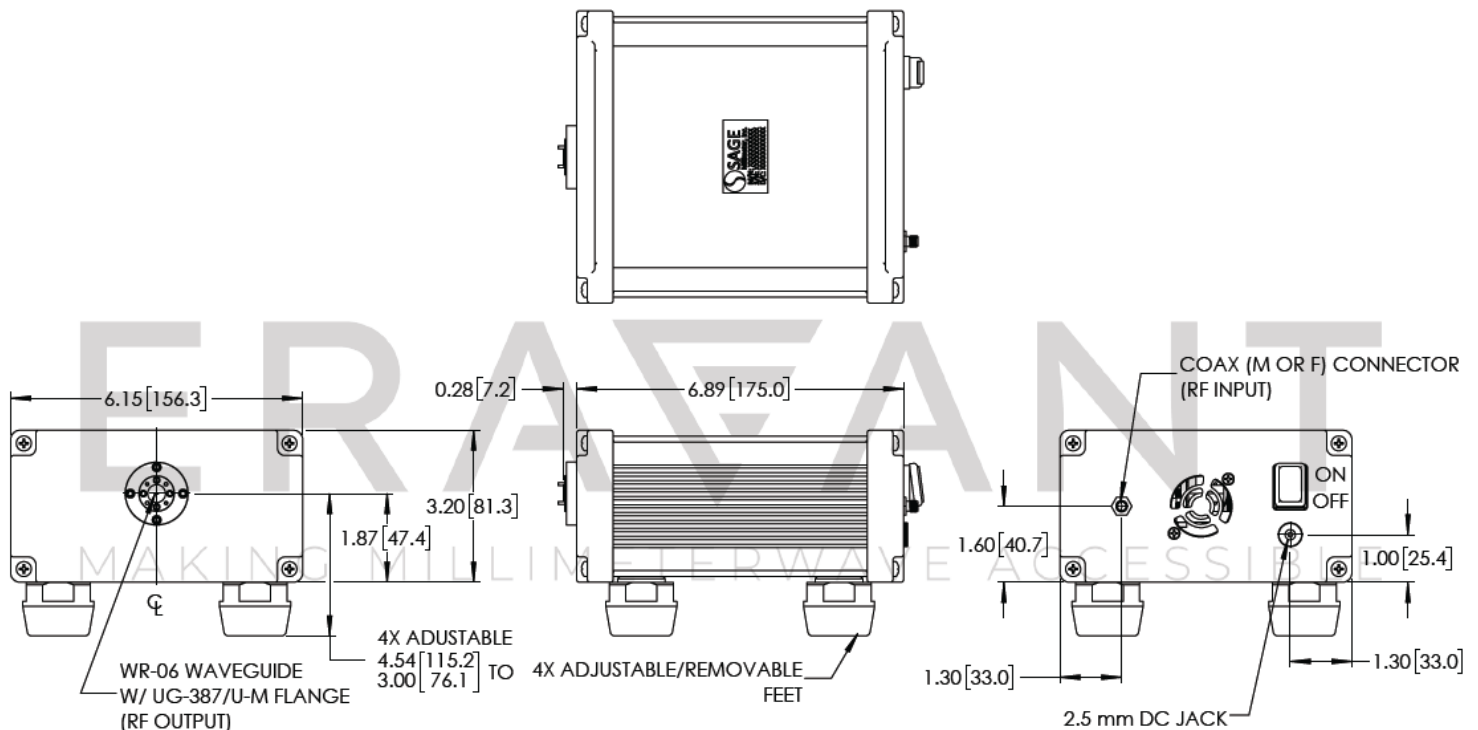

**NOTE:**

- On condition that test data is provided it is collected from a sample lot. Actual data may vary slightly from unit to unit. All testing is performed under +25 °C room temperature.
- On condition that simulated test data is provided, actual measured data may slightly vary.
- Other frequency multiplication factors are available under different model numbers.
- Eravant reserves the right to change the information presented without notice.

**CAUTION:**

- Exceeding absolute maximum ratings will damage the device.
- If a waveguide is present, any foreign objects in the waveguide will cause performance degradation and may damage or destroy the unit.
- For 1 mm connectors proper torque should be applied:  $4.0 \pm 0.15$  inch-pounds ( $0.45 \pm 0.02$  Nm). Torque wrench model SCH-06004-S1 is highly recommended.
- For 1.35 mm, 1.85 mm, 2.4 mm, 2.92 mm, and SMA connectors proper torque should be applied:  $8.0 \pm 0.15$  inch-pounds ( $0.90 \pm 0.02$  Nm). Torque wrench model SCH-08008-S1 is highly recommended.

ERAVANT  
MAKING MILLIMETERWAVE ACCESSIBLE

ERAVANT  
MAKING MILLIMETERWAVE ACCESSIBLE