

## STB-1834035535-KFKF-S1

### Broadband Low Noise Amplifier, 18 to 40 GHz, 55 dB Gain, +10 dBm P<sub>1dB</sub>

**STB-1834035535-KFKF-S1** is a broadband benchtop driver amplifier with a typical small signal gain of 55 dB and a nominal P<sub>1dB</sub> of +10 dBm across the frequency range of 18 to 40 GHz. The power supply required is a single phase AC voltage in the range of 100 to 240 V<sub>AC</sub>, which can be supplied by a wall outlet. The LED light helps to indicate the working status of the amplifier. The input and output port configurations are both female 2.92 mm connectors.



#### Electrical Specifications:

Parameter	Minimum	Typical	Maximum
Frequency Range	18 GHz		40 GHz
Gain		55 dB	
Gain Flatness			±4.5 dB
P <sub>-1dB</sub>	+8 dBm	+10 dBm	
Noise Figure		3.5 dB	
RF Input Power Damage Level			-35 dBm
Input Return Loss		10 dB	
Output Return Loss		10 dB	
Power Supply (AC Adapter Provided)	100 V <sub>AC</sub>		240 V <sub>AC</sub>
Specification Temperature		+25°C	
Operating Temperature	0°C		+50°C

#### Mechanical Specifications:

Item	Specification
Input	2.92 mm (K) Female
Output	2.92 mm (K) Female
DC Bias	2.5 mm DC Jack (AC-to-DC power converter included)
DC Bias Switch	Off-On Latching Switch with Indicator Light
Enclosure Material	Extruded Aluminum
Finish	Black Anodized
Weight	3 lbs
Outline	TB-SC-2

#### ECCN

EAR99

#### FEATURES

- Ultra-Broadband Coverage
- Good Gain Flatness
- Low Noise Figure

#### APPLICATIONS

- Bench Top Power Amplification
- Antenna Range

#### ACCESSORIES INCLUDED

- Waveguide Screwdriver, 3/32 Hex Head, SWH-332-DS
- SMA Connector Torque Wrench, [SCH-08008-S1](#)



## STB-1834035535-KFKF-S1

### Mechanical Outline:

Unless otherwise specified, all dimensions are in inches [millimeters]

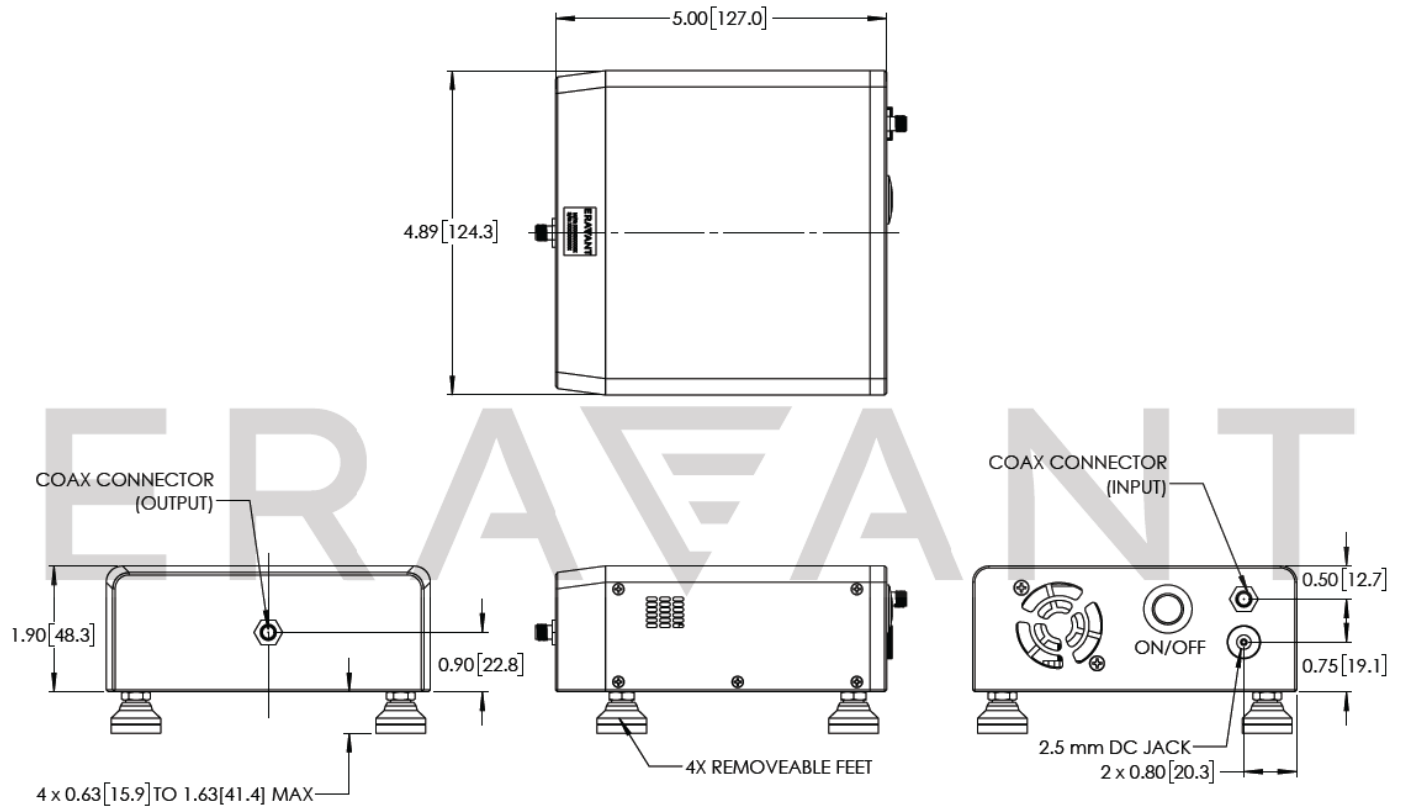

### NOTE:

- AC-to-DC power converter with cord is included.
- Eravant reserves the right to change the information presented without notice.

### CAUTION:

- Exceeding absolute maximum ratings shown will damage the device.
- The device is static sensitive. Always follow ESD rules when working with the device.
- The case temperature of the device shall never exceed +50°C/ Use proper heatsink or fan if necessary.
- For 1.35 mm, 1.85 mm, 2.4 mm, 2.92 mm, and SMA connectors proper torque should be applied:  $8.0 \pm 0.15$  inch-pounds ( $0.90 \pm 0.02$  Nm). Torque wrench model [SCH-08008-S1](#) is highly recommended

MAKING MILLIMETERWAVE ACCESSIBLE