



## V-Band Direct Reading Attenuator, Digital Reading

### Description:

**Model STA-60-15-D5** is a direct reading, rotary vane attenuator for use in millimeter wave systems across the standard V-band frequency range of 50 to 75 GHz. The attenuator has a digital screen which indicates the attenuation value directly. The attenuator is an ideal piece of equipment in waveguide systems where a broad direct reading of attenuation is required. The attenuator exhibits 1.0 dB maximum insertion loss and up to maximum 60 dB attenuation. The accuracy of the attenuator is 0.1 dB or 2% of the setting, whichever is larger, up to 40 dB, 3% up to 50 dB, and “for reference only” above 50 dB. The attenuator is powered by a rechargeable built-in battery, which can support up to 10 hours continuous operation with the back light “on” and 40 hours with the back light “off”. The battery can be charged by a provided AC adapter via a standard USB C cable or the attenuator can be operated while charging by using the AC adapter.



### Features:

- Full Band Coverage
- High Attenuation Accuracy
- Digital Screen with Back Light

### Applications:

- Test Lab
- Instrumentations
- Manual Test Set

### Electrical Specifications:

Parameter	Minimum	Typical	Maximum
RF Frequency Range	50 GHz		75 GHz
Insertion Loss		1.0 dB	1.5 dB
Attenuation Range	0 dB		60 dB
Attenuation Accuracy	0.1 dB or 2% of Setting, whichever is larger, up to 40 dB		
Resolution	0.01 dB Steps, 0 to 20 dB Range; 0.1 dB Steps, 20 to 60 dB Range		
Return Loss		20 dB	
Power Handling			300 mW
Battery Operation	10 Hours with Back Light “On” and 40 Hours with Back Light “Off”		
Power Switch	Sliding Latching		
Power On LED	Green		
AC Adapter Input	100 VAC		240 VAC
Specification Temperature		+25 °C	
Operating Temperature		+25 °C	

**\*This product is intended to be used in a controlled lab environment.**

**To ensure best possible accuracy and prevent unintended behavior, please operate the unit as close to +25 °C room temperature as possible.**



www.eravant.com | 501 Amapola Avenue, Torrance, CA 90501  
 Phone: 424-757-0168 | Fax: 424-757-0188 | Email: support@eravant.com



## V-Band Direct Reading Attenuator, Digital Reading

### Mechanical Specifications:

Item	Specification
RF Input	WR-15 Waveguide with UG-385/U Flange
RF Output	WR-15 Waveguide with UG-385/U Flange
Reading	Digital Display Screen
Step Size	0.01 dB, 0 to 20 dB Attenuation Range 0.1 dB, 20 to 60 dB Attenuation Range
Insertion Length	4.50" [114.3 mm]
Charger	AC Adapter
Charger Port	USB C Connector
Power Indicator	LED
Material	Body, Aluminum; Waveguide and Flange, Brass
Finish	Body, Black Anodized; Waveguide and Flange, Brass
Weight	29 Oz [825 g]
Outline	TA-DV-M2

### Typical Attenuation vs. Frequency

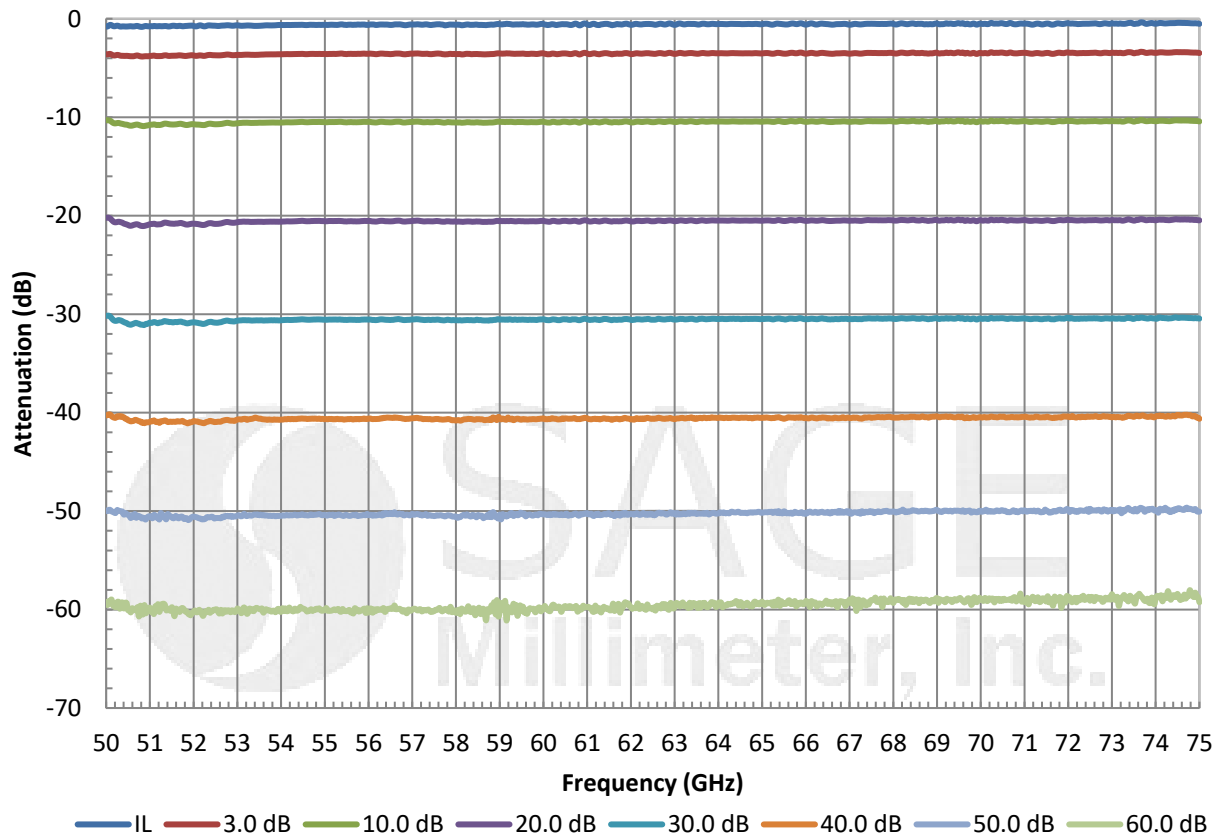



## V-Band Direct Reading Attenuator, Digital Reading

**Mechanical Outline:** (Unless otherwise specified, all dimensions are in inches)

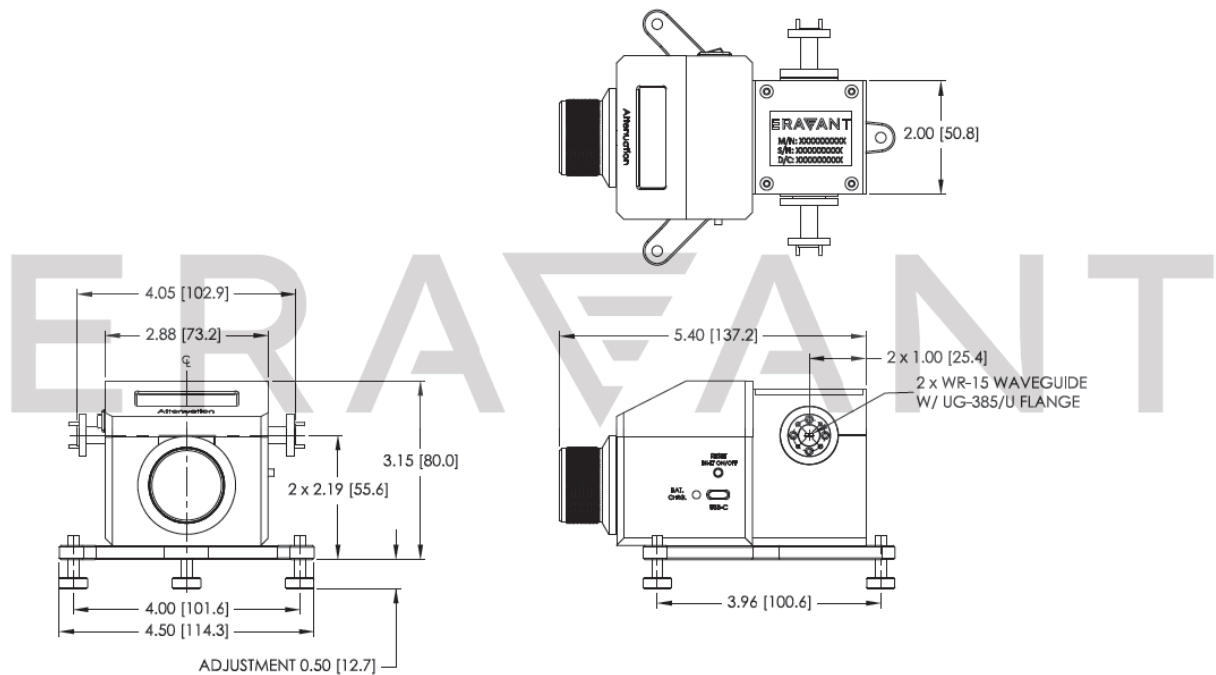

**Note:**

- Calibration accuracy is 0.1 dB or 2% of the setting, whichever is greater, for attenuation ranges up to 40 dB, 3% up to 50 dB, and “for reference only” above 50 dB.
- All calibration and testing are performed at +25 °C room temperature.
- **This product is intended to be used in a controlled lab environment. To ensure best possible accuracy and prevent unintended behavior, please operate the unit as close to +25 °C room temperature as possible.**
- The phase shift value does change while varying the attenuation.
- Using AC adapter is recommended while perform the testing to avoid the sudden power loss due to low battery power.
- Eravant reserves the right to change the information presented without notice.

**Caution:**

- Exceeding absolute maximum ratings shown will damage the device.
- Any foreign objects in the waveguide will cause performance degradation and may damage the device.

