



D-Band Direct Reading Attenuator

Description:

Model STA-60-06-D1 is a direct reading, rotary vane attenuator for use in millimeter wave systems across the standard D-band frequency range of 110 to 170 GHz. The attenuator has a large scale dial which indicates the attenuation value directly. The attenuator is an ideal piece of equipment in waveguide systems where a broad direct reading of attenuation is required. The attenuator exhibits 3.0 dB typical insertion loss and up to maximum 60 dB attenuation. The accuracy of the attenuator is 0.1 dB or 3% of the reading, whichever is larger, up to 40 dB, 5% up to 50 dB, and “for reference only” above 50 dB.



Features:

- Full Band Coverage
- High Attenuation Accuracy
- Large Scaled Dial

Applications:

- Test Lab
- Instrumentations
- Manual Test Set

Electrical Specifications:

Parameter	Minimum	Typical	Maximum
RF Frequency Range	110 GHz		170 GHz
Insertion Loss		3.0 dB	
Return Loss		18 dB	
Attenuation Range	0 dB		60 dB
Attenuation Accuracy	0.1 dB or 3% of reading, whichever is larger, up to 40 dB		
Power Handling			100 mW
Specification Temperature		+25 °C	
Operating Temperature		+25 °C	

***This product is intended to be used in a controlled lab environment.**

To ensure best possible accuracy and prevent unintended behavior, please operate the unit as close to +25 °C room temperature as possible.

Mechanical Specifications:

Item	Specification
RF Input	WR-06 Waveguide with UG-387/U-M Flange
RF Output	WR-06 Waveguide with UG-387/U-M Flange
Reading	Large Scale Dial
Scale Increments	0.01 dB (0 to 0.1 dB); 0.05 dB (0.1 to 1.0 dB); 0.1 dB (1.0 to 10 dB) 0.02 dB (10 to 20 dB); 0.05 dB (20 to 30 dB); 1.0 dB (30 to 50 dB)
Insertion Length	3.44"
Finish	Black Anodized
Weight	2.0 lb
Outline	TA-DD-M1





D-Band Direct Reading Attenuator

Mechanical Outline: (Unless otherwise specified, all dimensions are in inches)

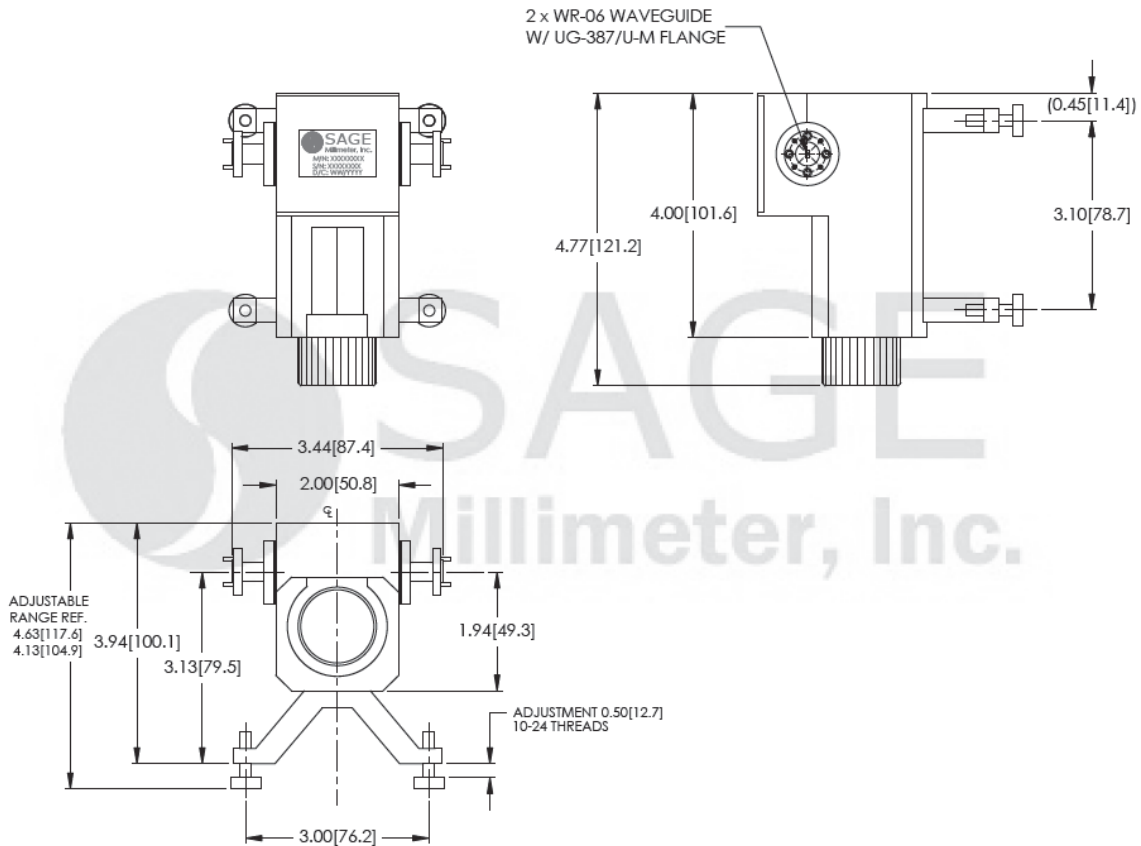

Note:

- Calibration accuracy is 0.1 dB or 3% of the reading, whichever is greater, for attenuation ranges up to 40 dB, 5% up to 50 dB, and “for reference only” above 50 dB.
- All calibration and testing are performed at +25 °C room temperature.
- **This product is intended to be used in a controlled lab environment. To ensure best possible accuracy and prevent unintended behavior, please operate the unit as close to +25 °C room temperature as possible.**
- The attenuation flatness is $\pm 2\%$ or ± 0.5 dB of the indicated value, whichever is greater, for the frequency band.
- The phase shift value does change while varying the attenuation.
- Eravant reserves the right to change the information presented without notice.

Caution:

- Exceeding absolute maximum ratings shown will damage the device.
- Any foreign objects in the waveguide will cause performance degradation and may damage the device.

