

V Band Ranging Sensor Module, Single Channel, 60.0 GHz, Bias Tuned

Description:

Model SSP-60310-S1-B is an E band ranging sensor module based on FMCW radar principles. This sensor module is designed and manufactured for measurements of a moving or stationary target's speed and distance. The sensor module has a center frequency of 60 GHz and takes a nominal bias of +5.0 V_{DC}/750 mA. The frequency modulation bandwidth of ±250 MHz is realized via a bias tuned Gunn oscillator. The advantages of implementing bias tuned oscillator are the lower cost and consistent frequency tuning linearity which are both desirable for volume production.

The sensor module is configured with a bias tuned oscillator, an isolator, a directional coupler, a circulator, and a balanced mixer. The directional coupler is used to sample the LO power to pump the mixer, and the circulator is used as a TX/RX diplexer. Various antennas can be integrated with the module to form sensor heads for many system applications.



Features:

- 76.5 GHz FMCW Operation
- Low FM/AM Noise and High Sensitivity
- Low Harmonic Emission
- Common Tx/Rx Port

Applications:

- True Ranging Radar Systems
- High Resolution Target Detection Systems
- Automotive Radar Systems

Electrical Specifications:

Parameter	Minimum	Typical	Maximum
Tx Frequency Range	59.75 GHz	60.0 GHz	60.25 GHz
Tx Output Power		+10 dBm	
FMCW Tuning Bandwidth		±250 MHz	
Rx Frequency Range	59.75 GHz	60.0 GHz	60.25 GHz
Rx IF Frequency Range	DC		1 GHz
Rx Conversion Loss		11 dB	
Bias Tuning Voltage Range		+4.5 to +5.5 V _{DC}	+6.5 V _{DC}
Bias Tuning Speed		1 mS	
Frequency Stability		-6.0 MHz/°C	
Power Stability		-0.04 dB/°C	
Bias Voltage	+3.5 V _{DC}	+5.0 V _{DC}	+5.5 V _{DC}
Bias Current		750 mA	950 mA
Specification Temperature		+25 °C	
Operating Temperature	0 °C		+50 °C

*Bias tuning speed can be improved per request.





V Band Ranging Sensor Module, Single Channel, 60.0 GHz, Bias Tuned

Mechanical Specifications:

Item	Specification
Tx/Rx Port	WR-15 Waveguide with UG-385/U Flange
IF Port	SMA (F)
DC Bias	Solder Pins and/or SMA (F)
Case Material	Aluminum and Brass
Finish	Gold Plated
Size	2.75" (W) X 1.99" (H) X 6.56" (L)
Weight	5.0 Oz
Outline	SP-NWEV-S1-B

Typical Frequency and Power Output vs. Bias Voltage

Bias: +4.5 to +5.5 Vdc/350 mA

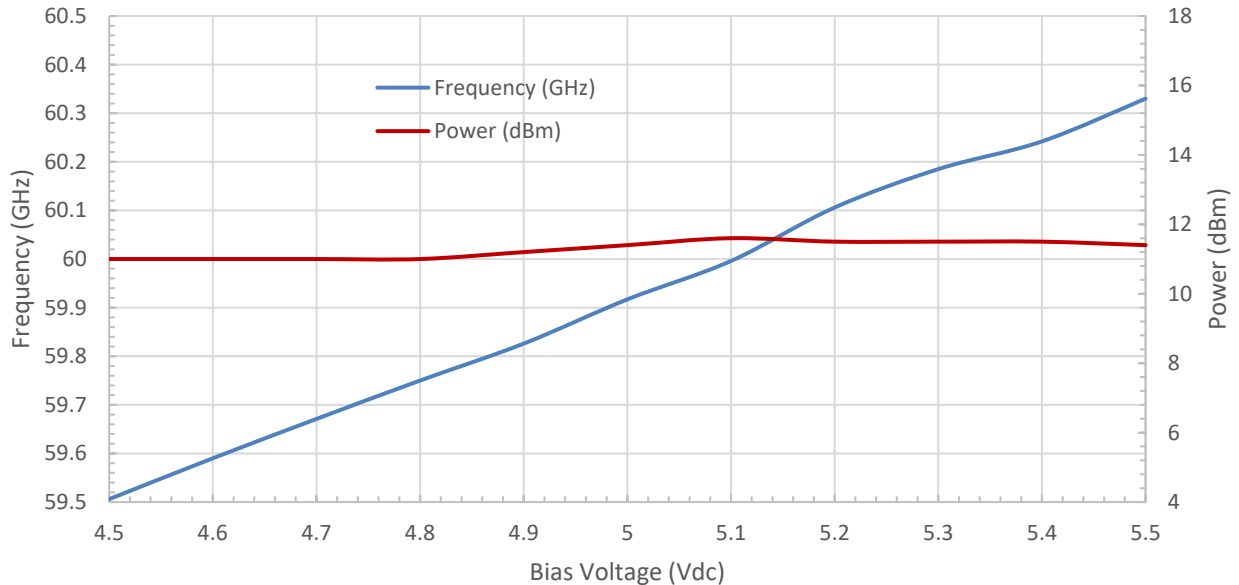

Block Diagram:

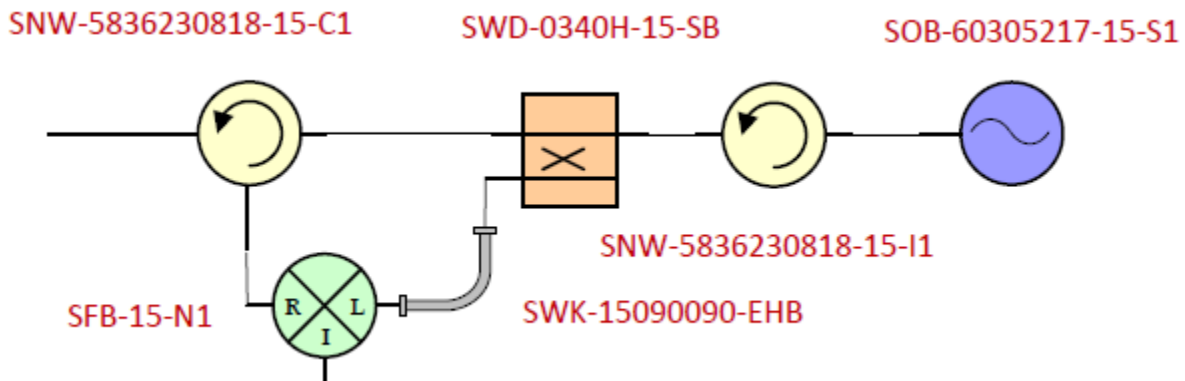

V Band Ranging Sensor Module, Single Channel, 60.0 GHz, Bias Tuned

Mechanical Outline: (Unless otherwise specified, all dimensions are in inches [mm])

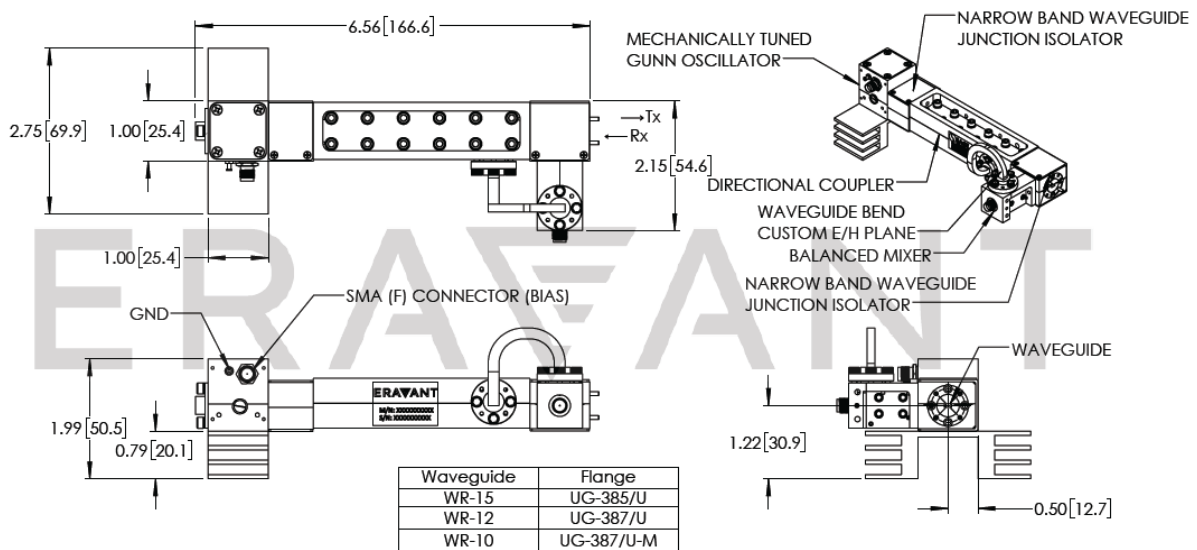

Note:

- All data are presented using a limited sample lot. Actual data may vary unit to unit.
- All testing was performed under +35 °C case temperature.
- Eravant reserves the right to change the information presented without notice.

Caution:

- Exceeding absolute maximum ratings shown will damage the device.
- The device is static sensitive. Always follow ESD rules when working with the device.
- Proper torque, 8.0 ± 0.4 inch-pounds (0.90 ± 0.02 Nm), should be applied. **Eravant torque wrench, model SCH-08008-S1, is highly recommended.**
- Any foreign objects in the waveguide will cause performance degradation and possibly damage the device.
- The case temperature of the device shall never exceed **+50 °C**. Use a proper heatsink or fan if necessary.

