



## Phase Locked Oscillator, 44 GHz, +20 dBm, Combined Internal and External Reference

### Description:

**Model SOP-44310120-22-B1** is a phase locked oscillator with a typical output frequency of 44 GHz and a nominal output power of +20 dBm. The oscillator utilizes the state-of-art technologies including a voltage controlled dielectric resonator oscillator, active multipliers, filters and power amplifiers to generate high-quality millimeter-wave signals. The phase locked oscillator has a built-in 100 MHz internal reference crystal oscillator as a backup reference if the 10 MHz external reference is absent. The oscillator delivers signal with a nominal harmonic and spurious levels of -20 dBc and -70 dBc, respectively.



### Features:

- Low Phase Noise
- Low Harmonic Components

### Applications:

- Radar Systems
- Communication Links
- Transmitters and Receivers

### Electrical Specifications:

Parameter	Minimum	Typical	Maximum
Frequency		44 GHz	
Output Power	+18 dBm	+20 dBm	
Phase Noise (Internal Reference) *	-80 dBc/Hz @10 kHz		
	-88 dBc/Hz @100 kHz		
	-118 dBc/Hz @1 MHz		
Internal Reference Frequency		100 MHz	
External Reference Frequency		10 MHz	
External Reference Input Power	-3 dBm	0 dBm	+3 dBm
Harmonics		-20 dBc	
Spurious		-70 dBc	
Phase Locked Indicator (LOCK)		TTL "High"	
Phase Error Voltage (V <sub>T</sub> )		0 to + 10 V <sub>DC</sub>	
DC Bias		+12 V <sub>DC</sub> / 1,250 mA	+15 V <sub>DC</sub>
Frequency Stability		±5 ppm	
Specification Temperature		+25 °C	
Operating Temperature	0 °C		+50 °C

\*Phase noise specified is based on the measured at microwave frequency and calculated based on adding 20log(N)+3 dB at millimeterwave frequency. In this case, N=2 is used for the estimation.



## Phase Locked Oscillator, 44 GHz, +20 dBm, Combined Internal and External Reference

### Mechanical Specifications:

Item	Specification
RF Output	WR-22 Waveguide with UG-383/U Anti-Cocking Flange
REF Input	SMA(F) Connector
REF Output	SMA(F) Connector
Bias Port	Feedthru Pin
Phase Lock Indicator Port (LD)	Feedthru Pin
Phase Error Voltage Port (V <sub>T</sub> )	Feedthru Pin
Case Material	Aluminum
Finishing	Black Anodized
Weight	8 Oz
Size	2.60" (W) X 6.00" (L) X 1.75" (H)
Outline	OP-BQ-A-FM

### System Block Diagram:

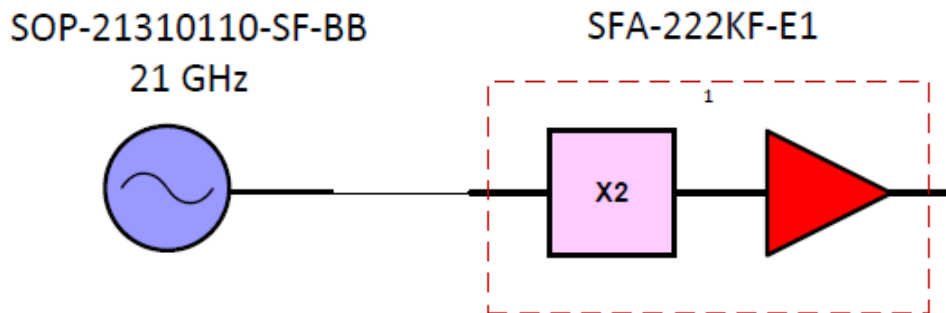

### Mechanical Outline: (Unless otherwise specified, all dimensions are in inches [millimeters])

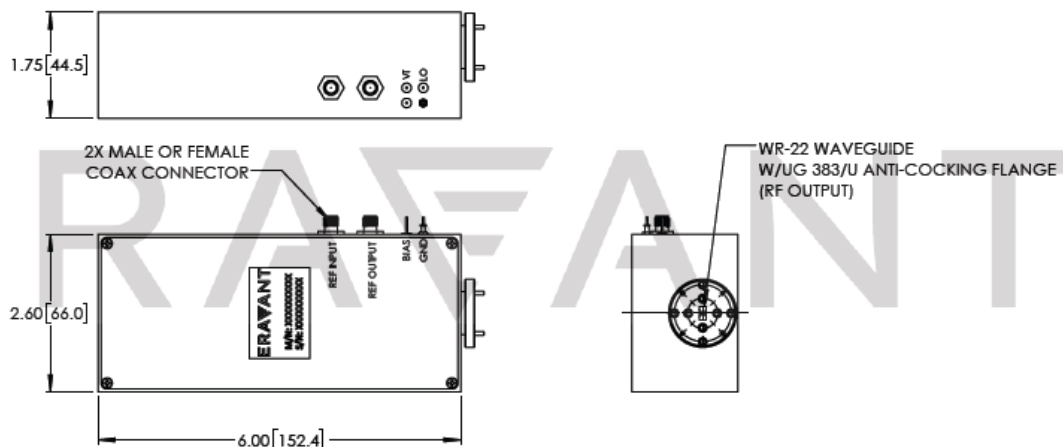



## Phase Locked Oscillator, 44 GHz, +20 dBm, Combined Internal and External Reference

### Note:

- Eravant reserves the right to change the information presented without notice.
- Other mechanical configurations are available under different model number.
- **The phase locked oscillators are single frequency signal generators. Many models are available with custom frequencies. The models published online are representative or selective. Contact factory for the models with specific frequency requirements.**

### Caution:

- Exceeding absolute maximum ratings shown will damage the device.
- The device is static sensitive. Always follow ESD rules when working with the device.
- The case temperature of the device shall never exceed **+50 °C**. Use additional heatsink or fan if necessary.
- Any foreign objects in the waveguide will cause performance degradation and possible device damage.
- Proper torque,  $8.0 \pm 0.15$  inch-pounds ( $0.90 \pm 0.02$  Nm), should be applied. **Eravant torque wrench, model SCH-08008-S1, is highly recommended.**

