

Phase Locked Oscillator, 120 GHz, +13 dBm, Combined Internal and External

SOP-12410113-06-B1 is a phase locked oscillator with a typical output frequency of 120 GHz and a nominal output power of +13 dBm. The oscillator utilizes the state-of-art technologies including a voltage controlled dielectric resonator oscillator, active multipliers, filters and power amplifiers to generate high-quality millimeter-wave signals. The phase locked oscillator has a built-in 100 MHz internal reference crystal oscillator as a backup reference if the 10 MHz external reference is absent. The oscillator delivers signal with a nominal harmonic and spurious levels of -15 dBc and -60 dBc, respectively.



Electrical Specifications:

| Parameter | Minimum | Typical | Maximum |
|---------------------------------------|---------|------------------------------|---------------------|
| Frequency | | 120 GHz | |
| Output Power | +10 dBm | +13 dBm | |
| Phase Noise (Internal Reference) * | | -70 dBc/Hz @10 kHz | |
| | | -80 dBc/Hz @100 kHz | |
| | | -105 dBc/Hz @1 MHz | |
| Internal Reference Frequency | | 100 MHz | |
| External Reference Frequency | | 10 MHz | |
| External Reference Input Power | -3 dBm | 0 dBm | +3 dBm |
| Harmonics | | -15 dBc | |
| Spurious | | -60 dBc | |
| Phase Locked Indicator (LOCK) | | TTL "High" | |
| Phase Error Voltage (VT) | | 0 to + 10 VDC | |
| DC Bias | | +12 V _{DC} / 750 mA | +15 V _{DC} |
| Frequency Stability | | ±5 ppm | |
| Specification Temperature | | +25 °C | |
| Operating Temperature | 0 °C | | +50 °C |

*Phase noise specified is based on the measured at microwave frequency and calculated based on adding 20log(N)+3 dB at millimeterwave frequency. In this case, N=6 is used for the estimation.

ECCN

EAR99

FEATURES

- Low Phase Noise
- Low Harmonic Components

APPLICATIONS

- Radar Systems
- Communication Links
- Transmitters and Receivers

SUPPLEMENTAL DETAILS



Mechanical Specifications:

| Item | Specification |
|------------------------------------|---|
| RF Output | WR-06 Waveguide with UG-387/U-M Anti-Cocking Flange |
| REF Input | SMA(F) Connector |
| REF Output | SMA(F) Connector |
| Bias Port | Feedthru Pin |
| Phase Lock Indicator Port (LD) | Feedthru Pin |
| Phase Error Voltage Port (V_T) | Feedthru Pin |
| Case Material | Aluminum |
| Finishing | Black Anodized |
| Weight | 8 Oz |
| Size | 2.60" (W) X 6.00" (L) X 1.75" (H) |
| Outline | OP-BD-A-FM |

System Block Diagram:

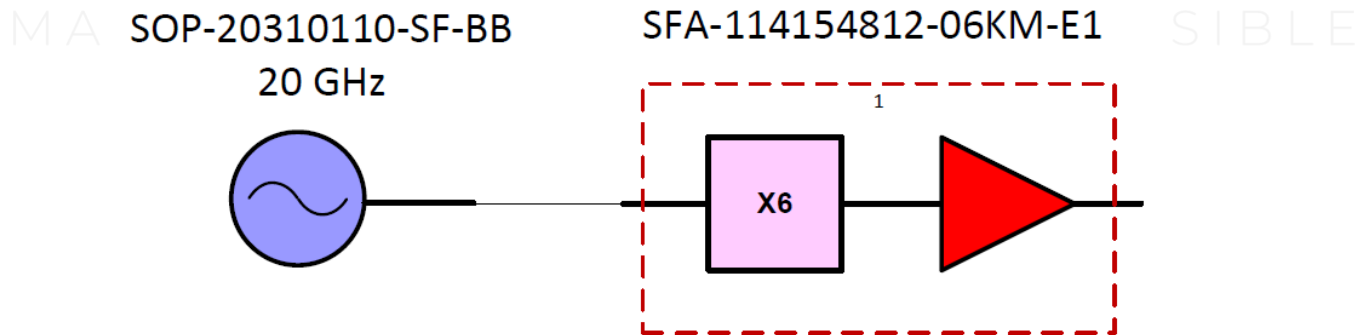

Mechanical Outline: (Unless otherwise specified, all dimensions are in inches [millimeters])

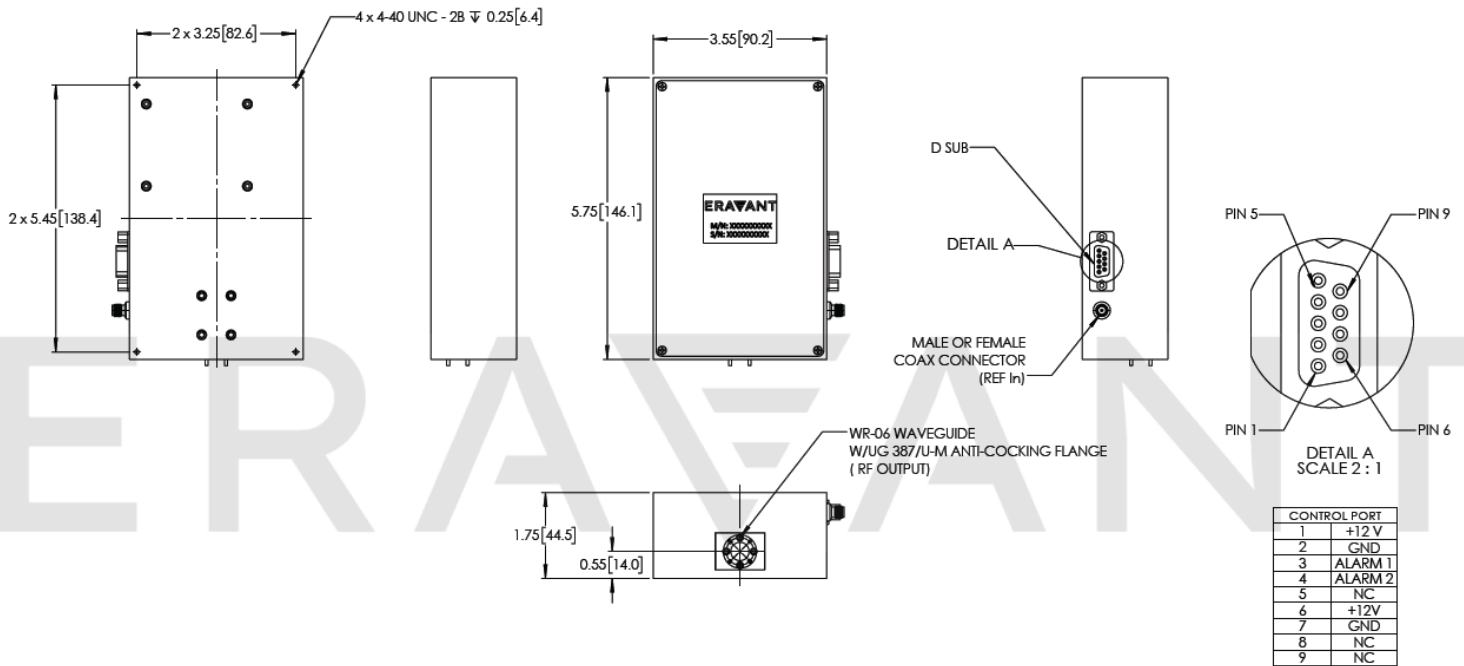

MAKING MILLIMETERWAVE ACCESSIBLE

NOTE:

- Eravant reserves the right to change the information presented without notice.
- Other mechanical configurations are available under different model number.
- **The phase locked oscillators are single frequency signal generators. Many models are available with custom frequencies. The models published online are representative or selective. Contact factory for the models with specific frequency requirements.**

CAUTION:

- Exceeding absolute maximum ratings shown will damage the device.
- The device is static sensitive. Always follow ESD rules when working with the device.
- The case temperature of the device shall never exceed +50 °C. Use additional heatsink or fan if necessary.
- Any foreign objects in the waveguide will cause performance degradation and possible device damage.
- Proper torque, 8.0 ± 0.15 inch-pounds (0.90 ± 0.02 Nm), should be applied. **Eravant torque wrench, model SCH-08008-S1, is highly recommended.**

MAKING MILLIMETERWAVE ACCESSIBLE