

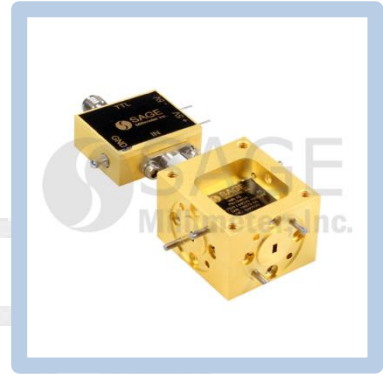

SPDT PIN Switch with TTL Driver, W Band

Description:

Model SKD-7531144020-1010-R1 is a PIN diode based, single pole, double throw (SPDT) switch with a TTL driver that operates across the entire W-band frequency range of 75 and 110 GHz. This model has an insertion loss of 4 dB typical and a nominal isolation of 20 dB at its center frequency. The SPDT switch features WR-10 waveguides with UG-387/U-M anti-cocking flanges at the RF input and outputs and a female SMA connector for TTL control on the driver. The switch can be modified for various operational frequencies under different model numbers.



Features:

- Full W Band Operation
- Low Insertion Loss
- High Isolation

Applications:

- Radar Systems
- Communication Systems
- Sensors
- Test Setups

Electrical Specifications:

Parameter	Minimum	Typical	Maximum
Frequency	75 GHz		110 GHz
Insertion Loss		4 dB	
Isolation		20 dB	
Power Handling		+20 dBm	+23 dBm
Bias Voltage		$\pm 5 V_{DC}$	
Bias Current		10 mA	
Control Signal		TTL	
Switching Speed		100 ns	
Specification Temperature		+25 °C	
Operating Temperature	0 °C		+50 °C

Mechanical Specifications:

Item	Specification
RF Ports	WR-10 Waveguides with UG-387/U-M Anti-Cocking Flanges
Bias Port	Feed Through Pins
TTL Control Port	SMA (F)
Case Material	Aluminum
Finish	Gold Plated
Weight	1.6 Oz
Outline	KD-RW-A





SPDT PIN Switch with TTL Driver, W Band

Typical Insertion Loss and Isolation vs. Frequency

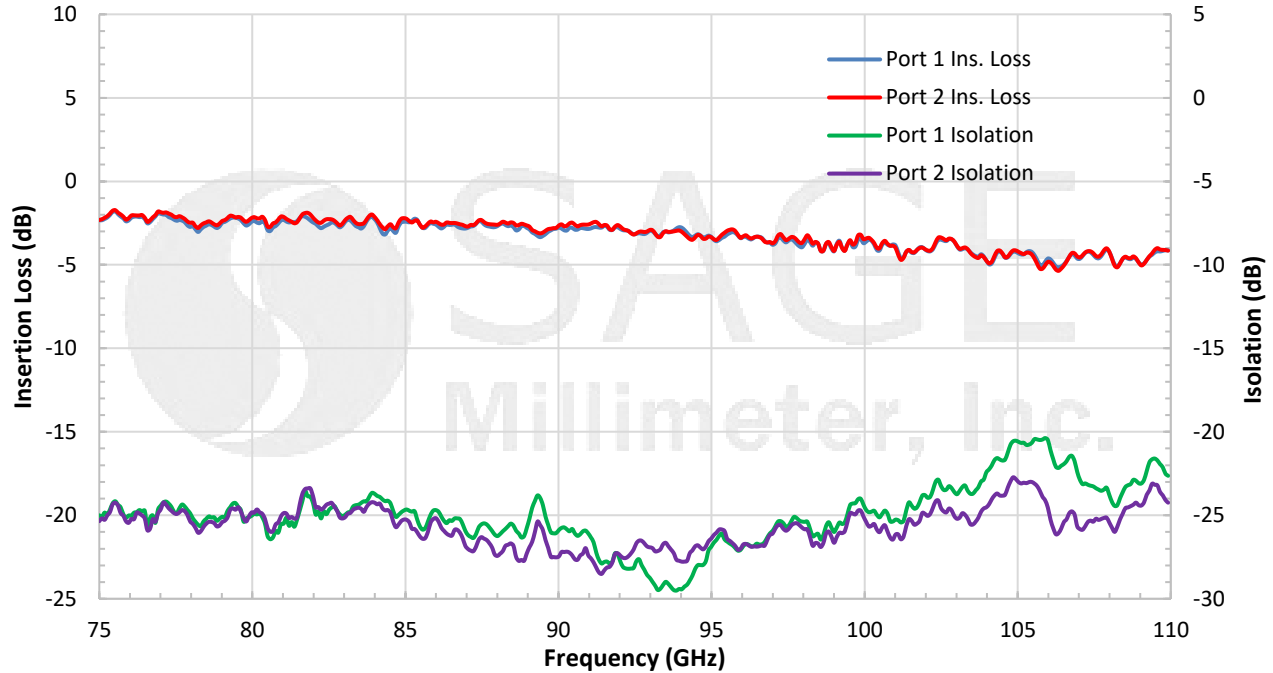

Mechanical Outline: (Unless otherwise specified, all dimensions are in inches [millimeters])

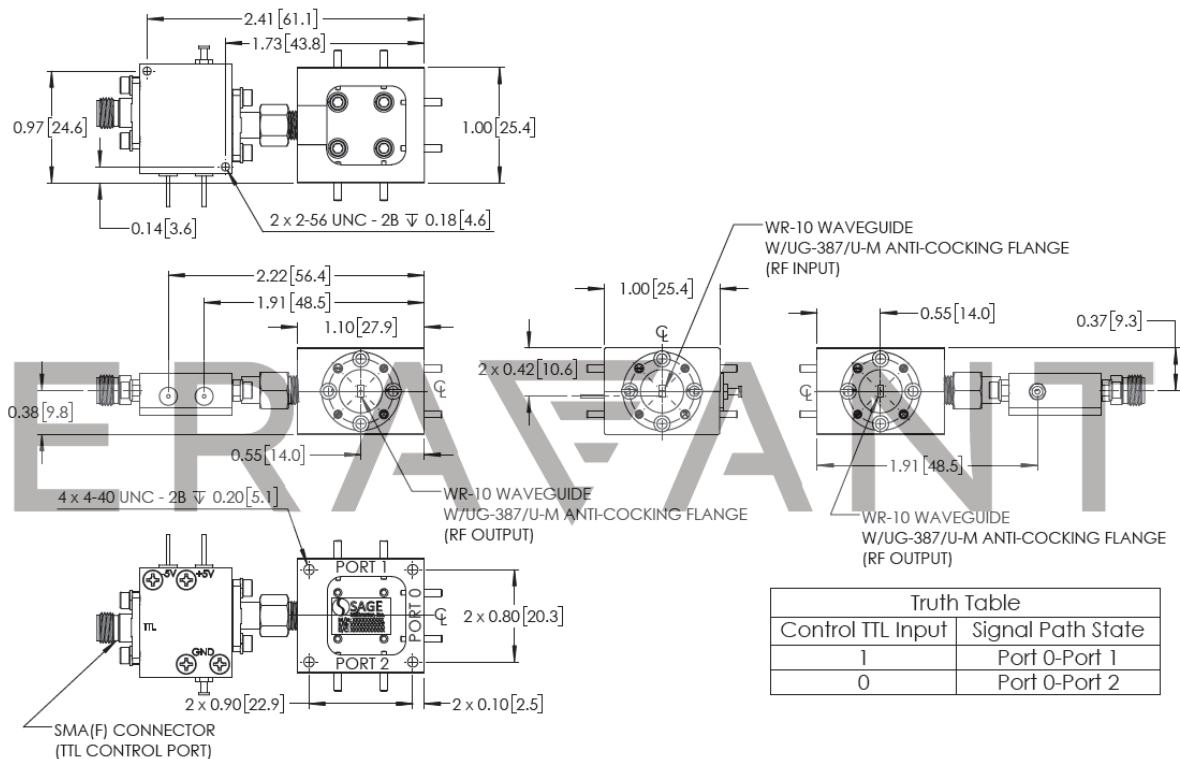



SPDT PIN Switch with TTL Driver, W Band

Note:

- All data presented is collected from a sample lot. Actual data may vary unit to unit slightly.
- All testing was performed under +25°C case temperature.
- Other mechanical configurations are available under different model numbers.
- SAGE Millimeter, Inc. reserves the right to change the information presented without notice.

Caution:

- Exceeding absolute maximum ratings shown will damage the device.
- The switch is a static sensitive device. Always follow ESD rules when working with the switch.
- Any foreign objects in the waveguide will cause performance degradation and possible device damage.
- Proper torque, 8.0 ± 0.15 inch-pounds (0.90 ± 0.02 Nm), should be applied. **SAGE Millimeter torque wrench, model SCH-08008-S1, is highly recommended.**

