



Coaxial Hybrid Coupler, 26.5 to 40 GHz, 90 Degrees

Description:

Model **SCZ-2734031209-KFKF-43** is a coaxial 90-degree hybrid coupler that covers the frequency range of 26.5 to 40 GHz. The nominal coupling is 3 dB and the typical insertion loss is 2.0 dB. The typical isolation of the coupler is 12 dB. The RF connectors of the coupler are female 2.92 mm (K) connectors. The power handling of the coupler is 20 watts maximum. Other configurations, such as different connectors for input and output, are available under different model numbers.



Features:

- Broad Band
- Low Insertion Loss
- Flat Coupling Level

Applications:

- Test Labs
- Instrumentations
- Sub-assemblies

Electrical Specifications:

Parameter	Minimum	Typical	Maximum
Frequency	26.5 GHz		40 GHz
Insertion Loss		2.0 dB	
Isolation		12 dB	
Coupling		3 dB	
Return Loss		11 dB	
Amplitude Unbalance		±0.7 dB	
Phase Unbalance		±10°	
Impedance		50 Ω	
Power Handling			20 W (CW)
Specification Temperature		+25 °C	
Operating Temperature	-45 °C		+85 °C

Mechanical Specifications:

Item	Specification
Input/Output Ports	K (F)
Case Material	Aluminum
Finishing	Epoxy Paint
Weight	0.8 Oz
Outline	CZ-KK-SR1



Coaxial Hybrid Coupler, 26.5 to 40 GHz, 90 Degrees

Mechanical Outline: (Unless otherwise specified, all dimensions are in inches [millimeters])

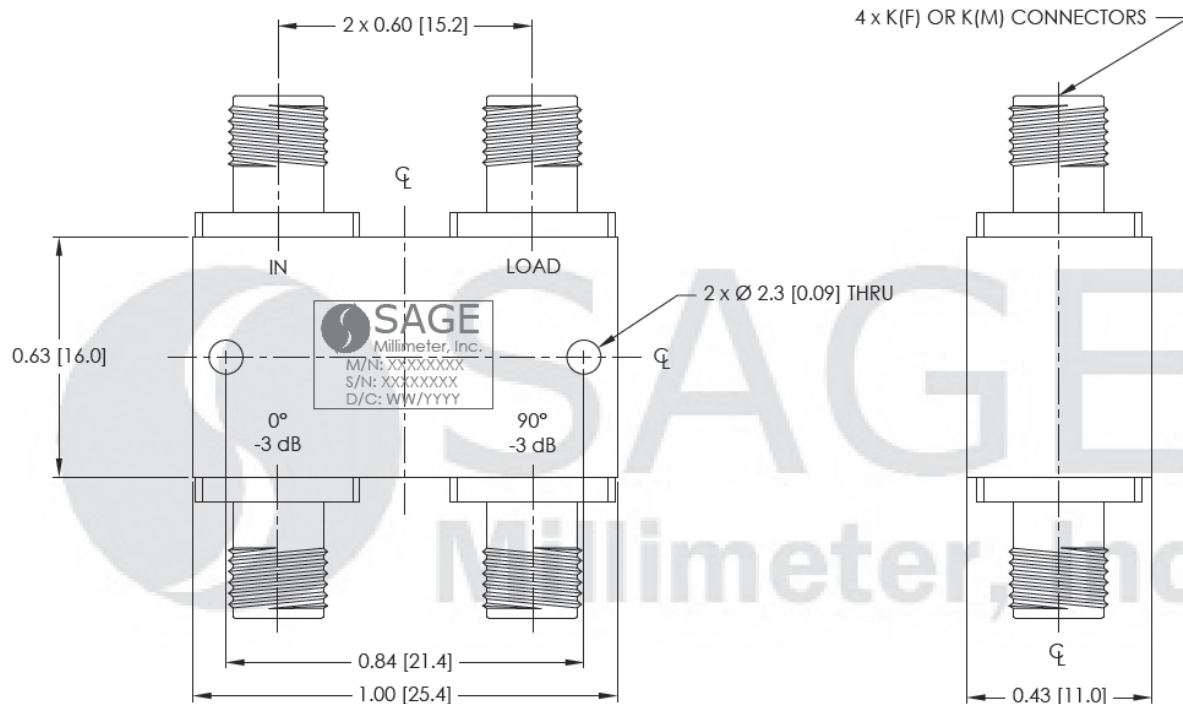

Note:

- Eravant reserves the right to change the information presented without notice.

Caution:

- Proper torque, 8.0 ± 0.15 inch-pounds (0.90 ± 0.02 Nm), should be applied. **Eravant torque wrench, model [SCH-08008-S1](#), is highly recommended.**