



Coaxial Bandpass Filter, 18 to 35 GHz

Description:

SCF-27317335-VFVF-B1 is a coaxial bandpass filter to pass the frequency of 18 to 35 GHz. The maximum insertion loss of the bandpass filter is 3.0 dB. The rejection frequencies are 15 GHz or less and 38 GHz or higher and the minimum rejection is 40 dB. The RF connectors of the the filter is V (F) connectors. The passband return loss of the filter is 10 dB maximum.



Electrical Specifications:

Parameter	Minimum	Typical	Maximum
Passband Frequency	18 GHz		35 GHz
Passband Insertion Loss			3 dB
Low Side Rejection Frequency			15 GHz
Low Side Rejection Value	40 dB	45 dB	
High Side Rejection Frequency	38 GHz		47 GHz
High Side Rejection Value	40 dB	45 dB	
Passband Return Loss	10 dB		
Impedance		50 Ω	
Specification Temperature		+25 $^{\circ}$ C	
Operating Temperature	-25 $^{\circ}$ C		+65 $^{\circ}$ C

Mechanical Specifications:

Item	Specifications
RF Ports	1.85 mm (F)
Case Material	Aluminum
Finish	Black Anodized
Size	1.10" (L) x 0.87" (W) x 0.28" (H)
Weight	0.4 Oz
Outline	CF-BKA-LJ2



Coaxial Bandpass Filter, 18 to 35 GHz

Typical Insertion Loss and Return Loss vs. Frequency

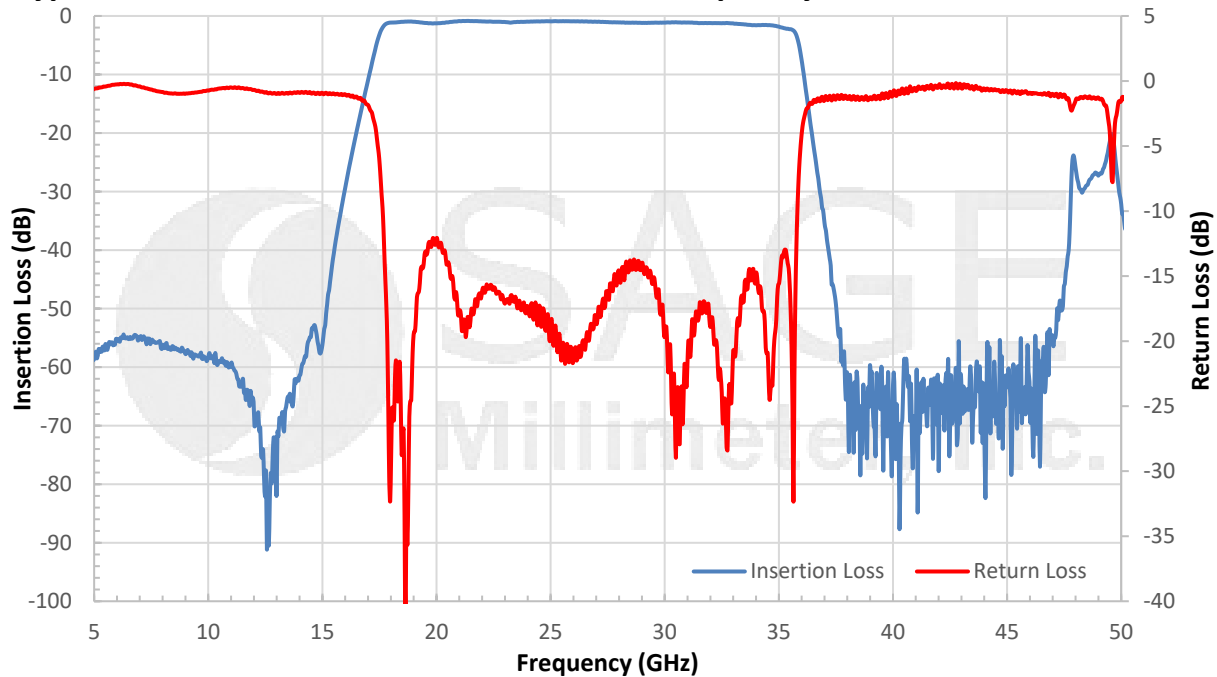

Mechanical Outline: (Unless otherwise specified, all dimensions are in inches)

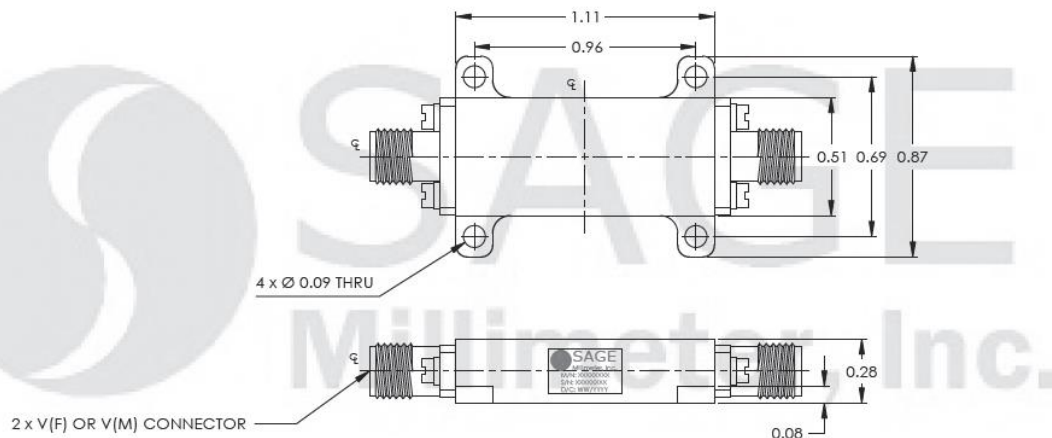

Note:

- All data presented is collected from a sample lot. Actual data may vary unit to unit.
- All testing was performed under +25 °C case temperature.
- Eravant reserves the right to change the information presented without notice.

Caution:

- Proper torque, 8.0 ± 0.15 inch-pounds (0.90 ± 0.02 Nm), should be applied. **Eravant torque wrench, model SCH-08008-U3, is highly recommended.**

www.eravant.com | 501 Amapola Avenue, Torrance, CA 90501
 Phone: 424-757-0168 | Fax: 424-757-0188 | Email: support@eravant.com