

SCA-05-SMSF-SD

SMA Coaxial Fixed Attenuator, 5 dB Attenuation

SCA-05-SMSF-SD is a 5 dB coaxial attenuator that is used in millimeterwave systems and operates from DC to 26.5 GHz. The attenuator has a typical attenuation value of 5 dB across the frequency range. While the attenuator is designed and fabricated for full SMA coaxial band applications, the attenuation value of this model will have a wide range due to its broadband coverage. Various attenuation values are available under different model numbers.



Electrical Specifications:

Parameter	Minimum	Typical	Maximum
Frequency Range	DC		26.5 GHz
Attenuation		5 dB	
Attenuation Accuracy		±0.5 dB	
Return Loss		20 dB	
Power Handling			2W (CW)
Impedance		50 Ω	
Specification Temperature		+25 °C	
Operating Temperature	-40 °C		+85 °C

Mechanical Specifications:

Item	Specification
Connector 1 Type	SMA Male
Connector 2 Type	SMA Female
Body Material	Stainless Steel
Body Finish	Passivated
Connector Pin Material	Beryllium Copper
Connector Pin Finish	Gold Plated
Insulator Material	PTFE
Weight	0.3 Oz
Length	0.64"
Outline	CA-S-9

ECCN

EAR99

FEATURES

- Broadband Coverage
- Low Cost

APPLICATIONS

- Test Lab
- Instrumentations
- System Integration

SUPPLEMENTAL DETAILS



SCA-05-SMSF-SD

Typical Performance vs. Frequency

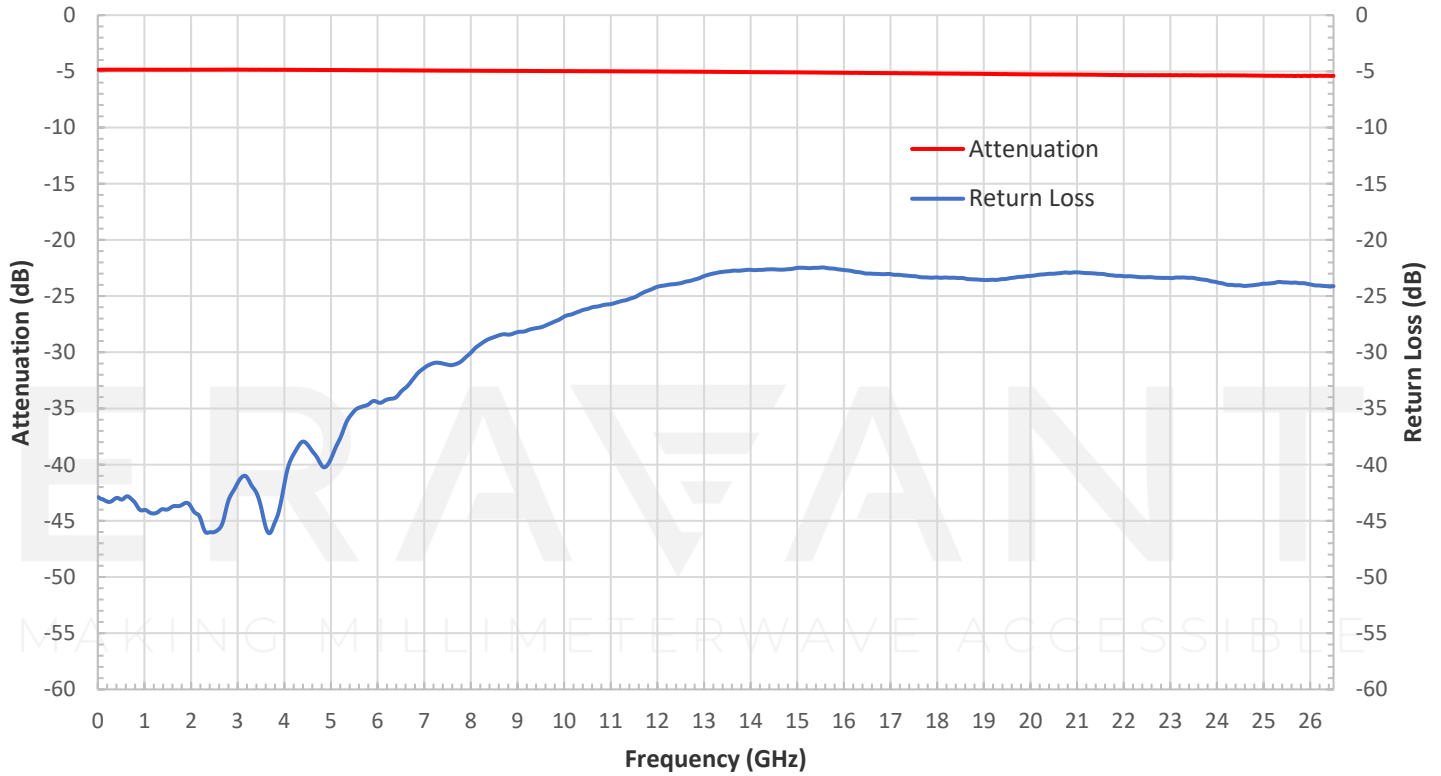

Mechanical Outline: (Unless otherwise specified, all dimensions are in inches [millimeters])

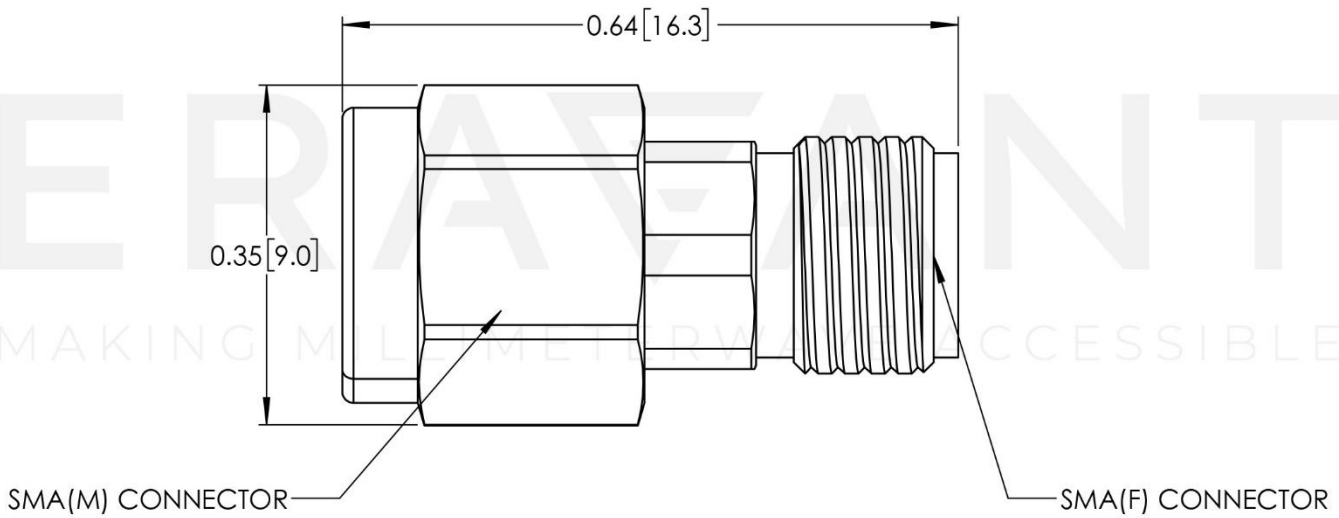

NOTE:

- All data presented is collected from a sample lot. Actual data may vary slightly from unit to unit.
- All testing is performed under +25 °C case temperature.
- Eravant reserves the right to change the information presented without notice.

CAUTION:

- Exceeding absolute maximum ratings shown will damage the device.
- Proper torque should be applied: 8.0 ± 0.15 inch-pounds (0.90 ± 0.02 Nm). Torque wrench model SCH-08008-S1 is highly recommended.

ERAVANT

MAKING MILLIMETERWAVE ACCESSIBLE

ERAVANT

MAKING MILLIMETERWAVE ACCESSIBLE