



## V-Band Power Amplifier, 50 to 75 GHz, 10 dB Gain, +16 dBm P<sub>1dB</sub>

### Description:

**Model SBP-5037531016-1515-E1** is V-Band power amplifier with a typical small signal gain of 10 dB and P<sub>1dB</sub> of +16 dBm in the frequency range of 50 to 75 GHz. The saturated output power of the amplifier is +20 dBm. The DC power requirement for the amplifier is +8 V<sub>DC</sub>/350 mA. The mechanical configuration offers an inline structure with WR-15 waveguides and UG-385/U anti-cocking flanges. Other port configurations, such as with 1 mm connectors or right angle structure with WR-15 waveguides, are also available under different model numbers.



### Features:

- Full Waveguide Band Coverage
- Moderate Output Power

### Applications:

- Radar Systems
- Communication Systems
- Test Equipment

### Electrical Specifications:

Parameter	Minimum	Typical	Maximum
Frequency	50 GHz		75 GHz
Gain		10 dB	
P <sub>1dB</sub>		+16 dBm	
P <sub>sat</sub>		+20 dBm	
P <sub>in</sub>			+17 dBm
Input Return Loss		10 dB	
Output Return Loss		10 dB	
DC Voltage	+6 V <sub>DC</sub>	+8 V <sub>DC</sub>	+15 V <sub>DC</sub>
DC Supply Current		350 mA	
Specification Temperature		+25 °C	
Operating Temperature	0 °C		+50 °C

### Mechanical Specifications:

Item	Specification
Input Port	WR-15 Waveguide with UG-385/U Anti-Cocking Flange
Output Port	WR-15 Waveguide with UG-385/U Anti-Cocking Flange
Bias	Solder Pin
Case Material	Aluminum
Finish	Gold Plated
Weight	1.6 Oz
Size	1.10" (W) X 1.50" (L) X 0.75" (H)
Outline	BG-SV-2-A





## V-Band Power Amplifier, 50 to 75 GHz, 10 dB Gain, +16 dBm P<sub>1dB</sub>

### Typical Gain and Return Loss vs. Frequency

Bias: +8 V<sub>DC</sub>/350 mA

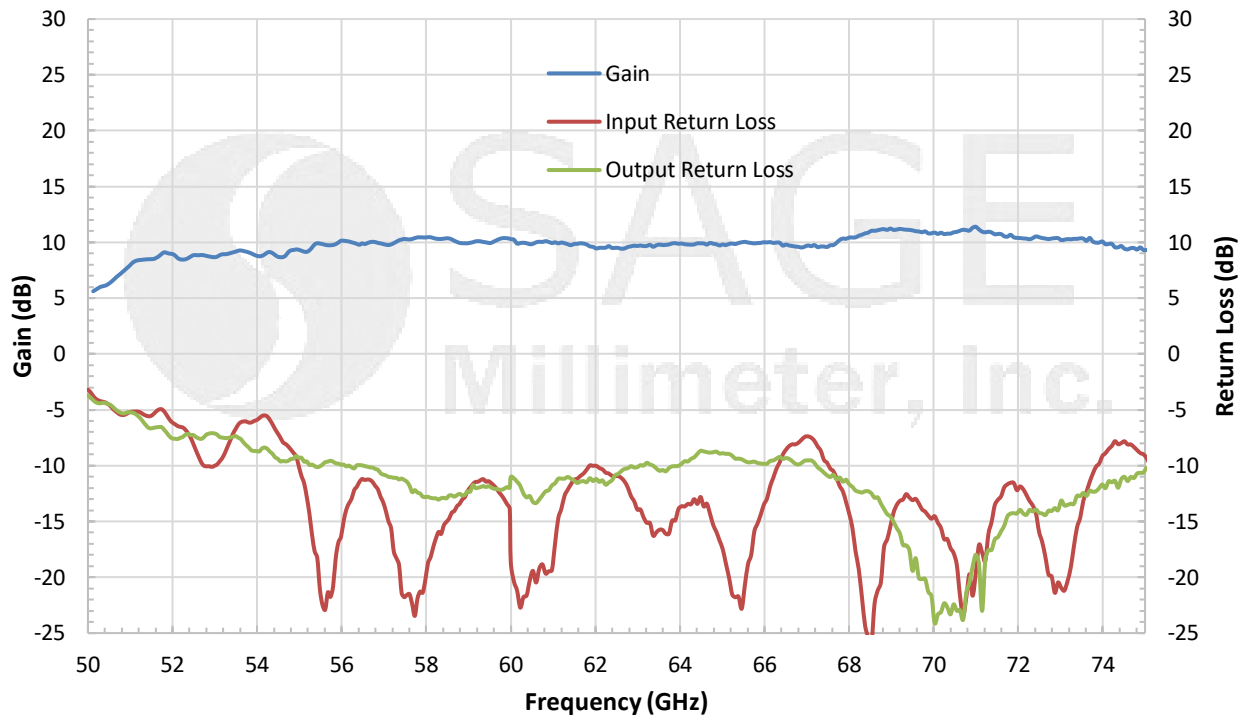

### Typical Output Power vs. Frequency

Bias: +8 V<sub>DC</sub>/395 mA

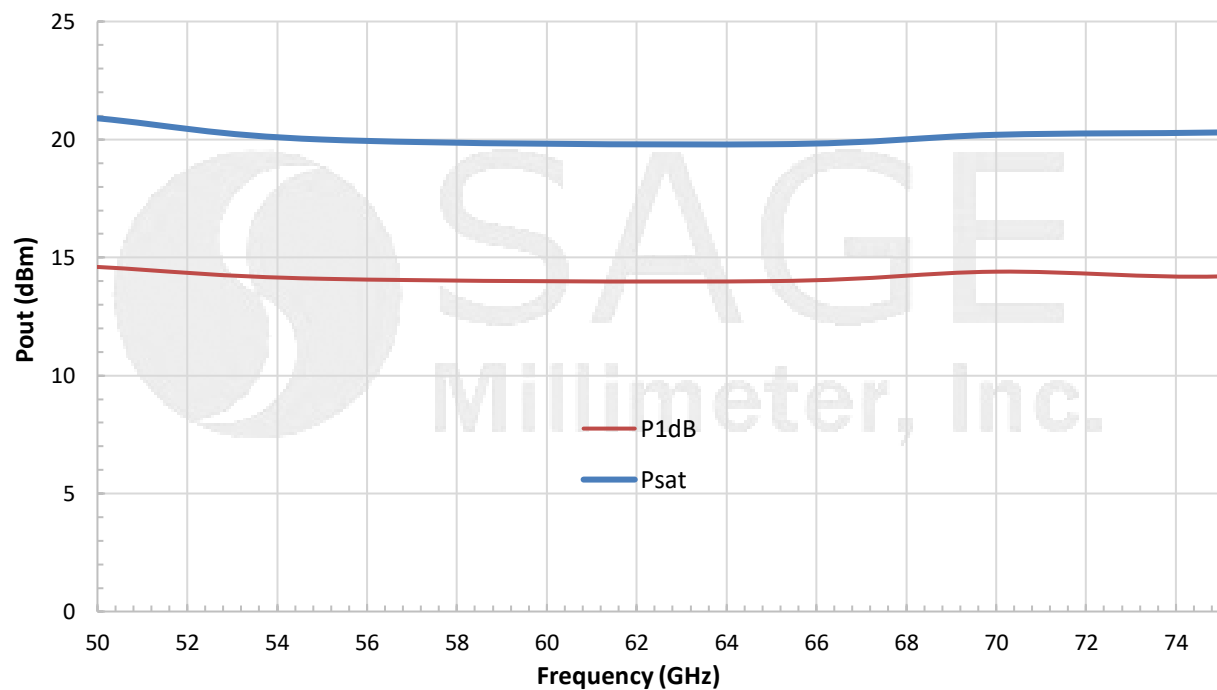



## V-Band Power Amplifier, 50 to 75 GHz, 10 dB Gain, +16 dBm P<sub>1dB</sub>

**Mechanical Outline:** (Unless otherwise specified, all dimensions are in inches [millimeters])

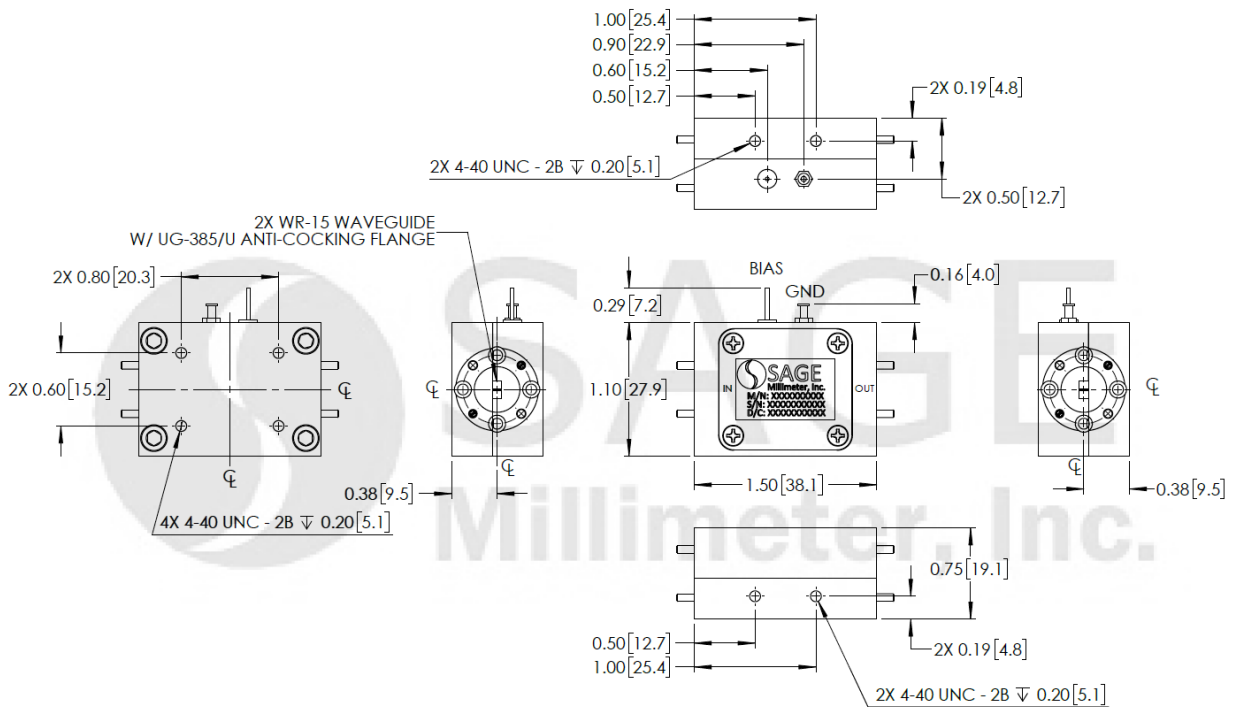

**Note:**

- All data presented is collected from a sample lot. Actual data may vary unit to unit.
- All testing was performed under +25 °C case temperature.
- SAGE Millimeter, Inc. reserves the right to change the information presented without notice.
- Other mechanical configurations are available under different model numbers.

**Caution:**

- Exceeding absolute maximum ratings shown will damage the device.
- The device is static sensitive. Always follow ESD rules when working with the device.
- The case temperature of the device shall never exceed +50 °C. Use proper heatsink or fan if necessary.
- Any foreign objects in the waveguide will cause performance degradation and may damage the device.

