



Q-Band Power Amplifier, 33 to 50 GHz, 30 dB Gain, +18 dBm P_{1dB}

Description:

Model SBP-3335033018-2222-S1 is a power amplifier with a typical small signal gain of 30 dB and a nominal P_{1dB} of +18 dBm across the frequency range of 33 to 50 GHz. The DC power requirement for the amplifier is +8 V_{DC}/650 mA. The mechanical configuration offers a right angle structure with WR-22 waveguides and UG-383/U flanges. Other port configurations, such as an in line structure with WR-22 waveguides or 2.4 mm connectors, are also available under different model numbers.



Features:

- Full Waveguide Band Coverage
- High Output Power
- High Gain

Applications:

- Radar Systems
- Communication Systems
- Test Equipment

Electrical Specifications:

Parameter	Minimum	Typical	Maximum
Frequency	33 GHz		50 GHz
Gain		30 dB	
P _{1dB}		+18 dBm	
P _{SAT}		+20 dBm	
P _{in}			-1 dBm
Input Return Loss		10 dB	
Output Return Loss		10 dB	
DC Voltage	+6 V _{DC}	+8 V _{DC}	+15 V _{DC}
DC Supply Current		650 mA	
Specification Temperature		+25 °C	
Case Temperature	0 °C		+50 °C

Mechanical Specifications:

Item	Specification
Input Port	WR-22 Waveguide with UG-383/U Flange
Output Port	WR-22 Waveguide with UG-383/U Flange
Bias	Solder Pin
Case Material	Aluminum
Finish	Gold Plated
Weight	2.0 Oz
Size	1.20" (W) X 2.60" (L) X 0.50" (H)
Outline	BG-SQ-1





Q-Band Power Amplifier, 33 to 50 GHz, 30 dB Gain, +18 dBm P_{1dB}

Gain and Return Loss vs. Frequency

Bias: +8 V_{DC}/650 mA

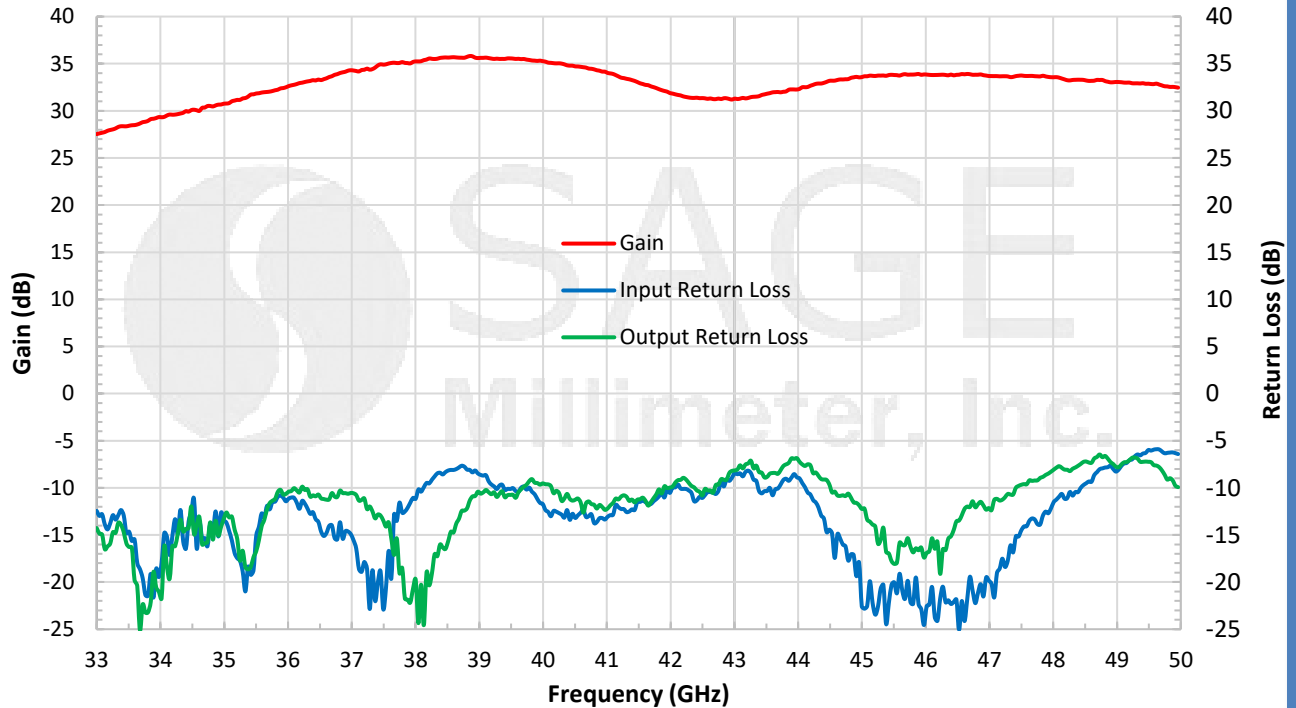

Typical P_{1dB} vs. Frequency

Bias: +8 V_{DC}/850 mA

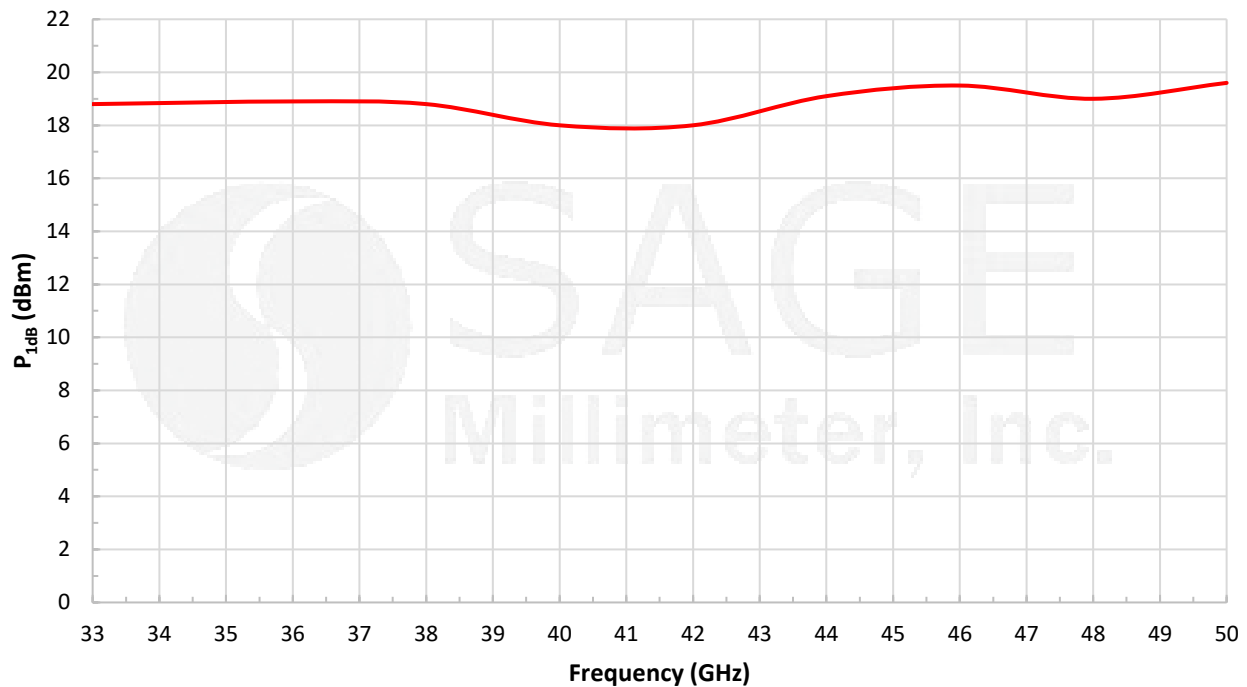



Q-Band Power Amplifier, 33 to 50 GHz, 30 dB Gain, +18 dBm P_{1dB}

Mechanical Outline: (Unless otherwise specified, all dimensions are in inches)

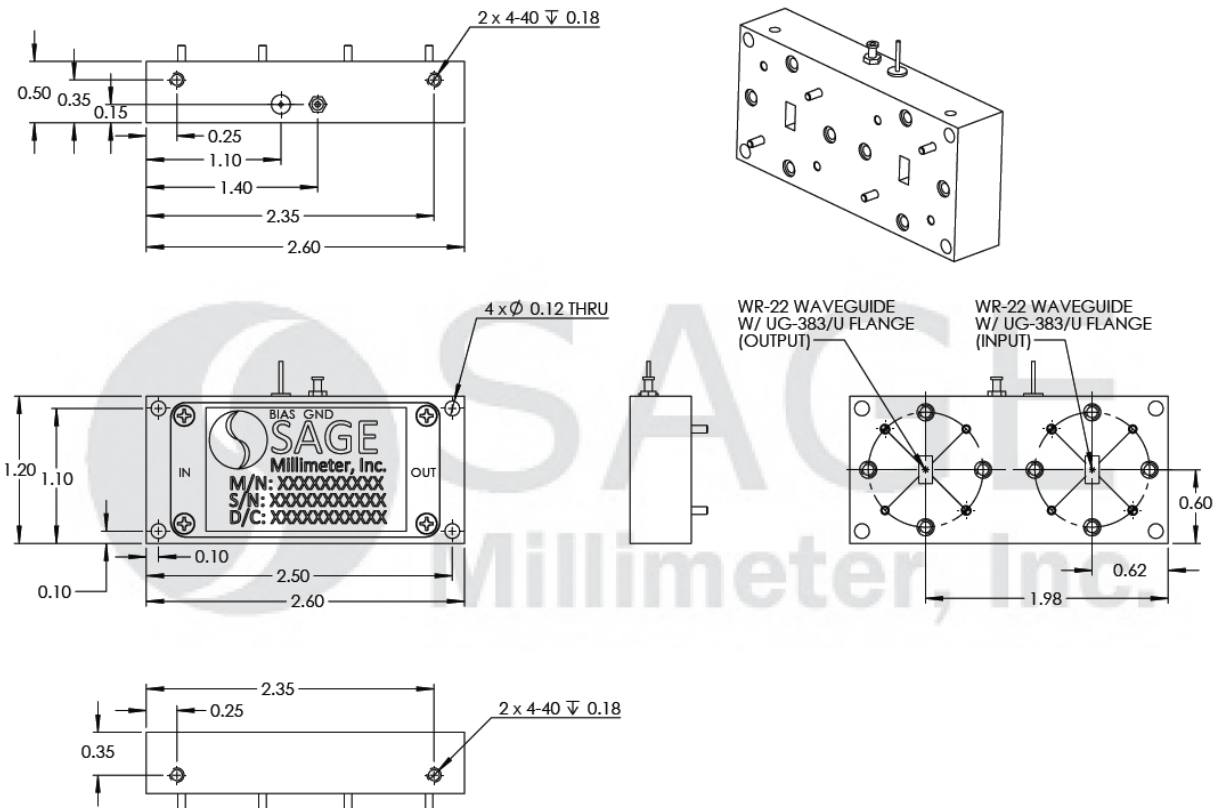

Note:

- All data presented is collected from a sample lot. Actual data may vary unit to unit.
- All testing was performed under +25 °C case temperature.
- SAGE Millimeter, Inc. reserves the right to change the information presented without notice.
- Other mechanical configurations are available under different model numbers.

Caution:

- Exceeding absolute maximum ratings shown will damage the device.
- The device is static sensitive. Always follow ESD rules when working with the device.
- The case temperature of the device shall never exceed +50 °C. Use proper heatsink or fan if necessary.
- Any foreign objects in the waveguide will cause performance degradation and may damage the device.

