

## SBP-2632735143-KFKF-EP

### 25.5 to 26.5 GHz Power Amplifier, 51 dB Gain, +43 dBm P<sub>sat</sub>

**SBP-2632735143-KFKF-EP** is a power amplifier with a typical small gain of 51 dB and a nominal P<sub>sat</sub> of +43 dBm across the frequency range of 25.5 to 26.5 GHz. The DC power requirement for the amplifier is +22 V<sub>DC</sub>/5.5 A and is enabled or disabled via TTL input. The mechanical configuration is an inline structure with K (F) connector as its input port and output port. Other port configurations, such as K (M) connectors and WR-42 waveguides for either the input or output port, are also available under different model numbers.



#### Electrical Specifications:

Parameter	Minimum	Typical	Maximum
Frequency	25.5 GHz		26.5 GHz
Small Signal Gain		51dB	
Power Gain		43 dB	
P <sub>sat</sub>		+43 dBm	
P <sub>in</sub>			+8 dBm
Input Return Loss		10 dB	
Output Return Loss		5 dB	
Off / On Control	TTL "Low"		TTL "High"
DC Supply Voltage (VDD)	+20 V <sub>DC</sub>	+22 V <sub>DC</sub>	+24 V <sub>DC</sub>
DC Supply Current		5.5 A	
Supply Voltage to Fan		+12 V <sub>DC</sub> /1.8 A	
Specification Temperature		+25 °C	
Operating Temperature	0 °C		+50 °C

#### Mechanical Specifications:

Item	Specification
Input	2.92 mm (K) Female
Output	2.92 mm (K) Female
Power Supply/TTL	Solder Pin
Case Material	Copper
Finish	Gold Plated
Size	2.99" (L) X 3.15" (W) X 3.30" (H)
Outline	BP-HC-H3

#### ECCN

3A001.b.4

#### FEATURES

- Class AB GaN Technique
- Broadband Performance
- High Gain
- High Output Power
- TTL Control

#### APPLICATIONS

- Radar Systems
- Communication Systems
- Test Equipment

#### SUPPLEMENTAL DETAILS



### Typical Gain vs. Frequency

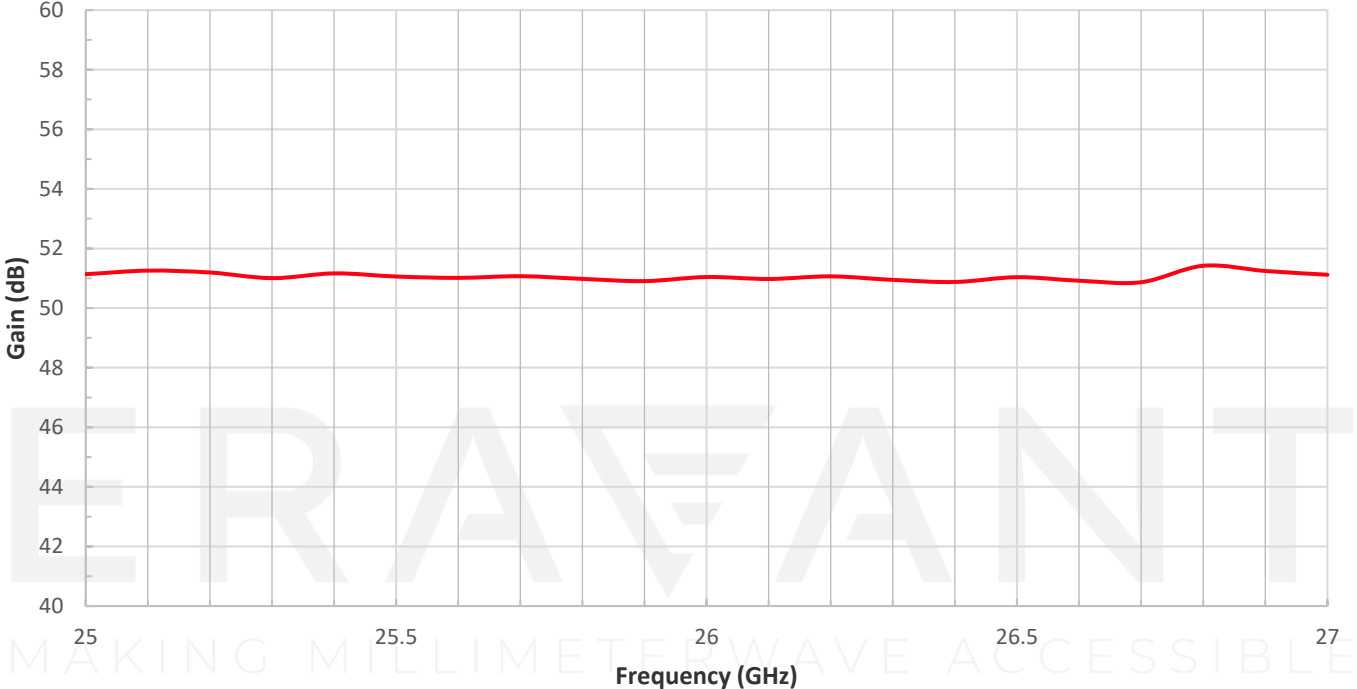

### Typical P<sub>SAT</sub> vs. Frequency

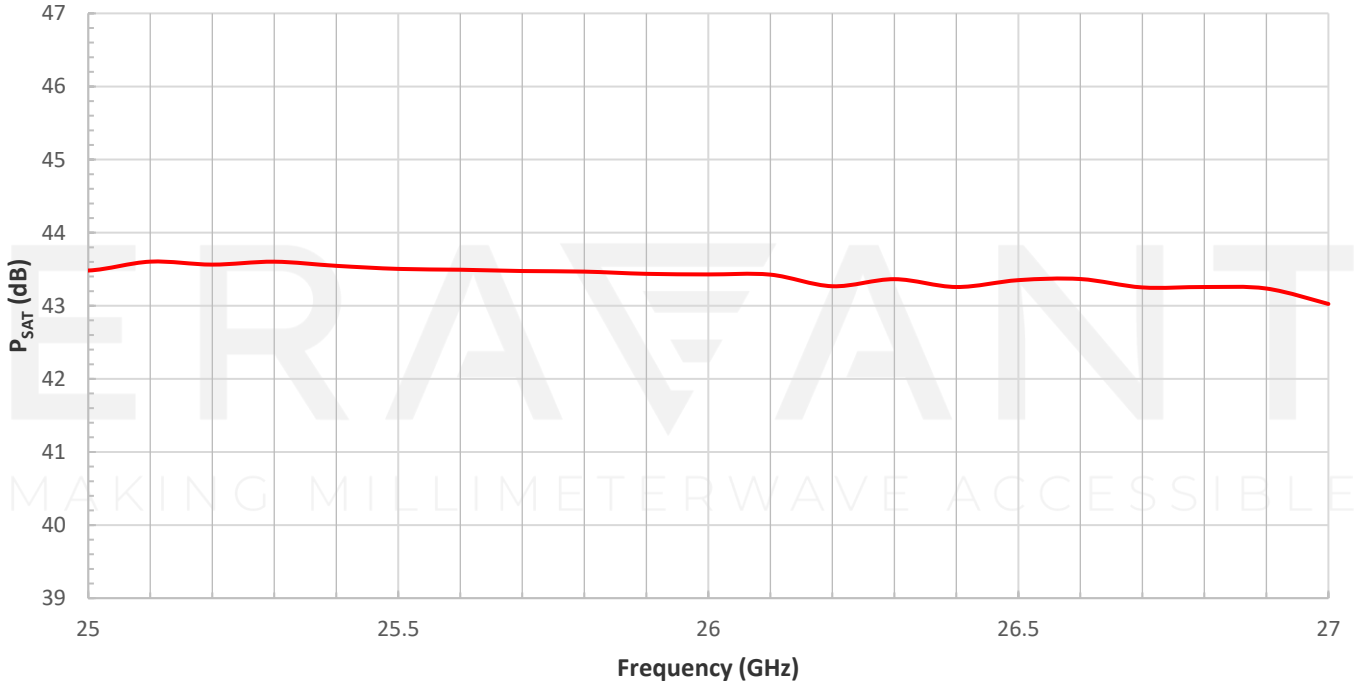

Typical PAE vs. Frequency

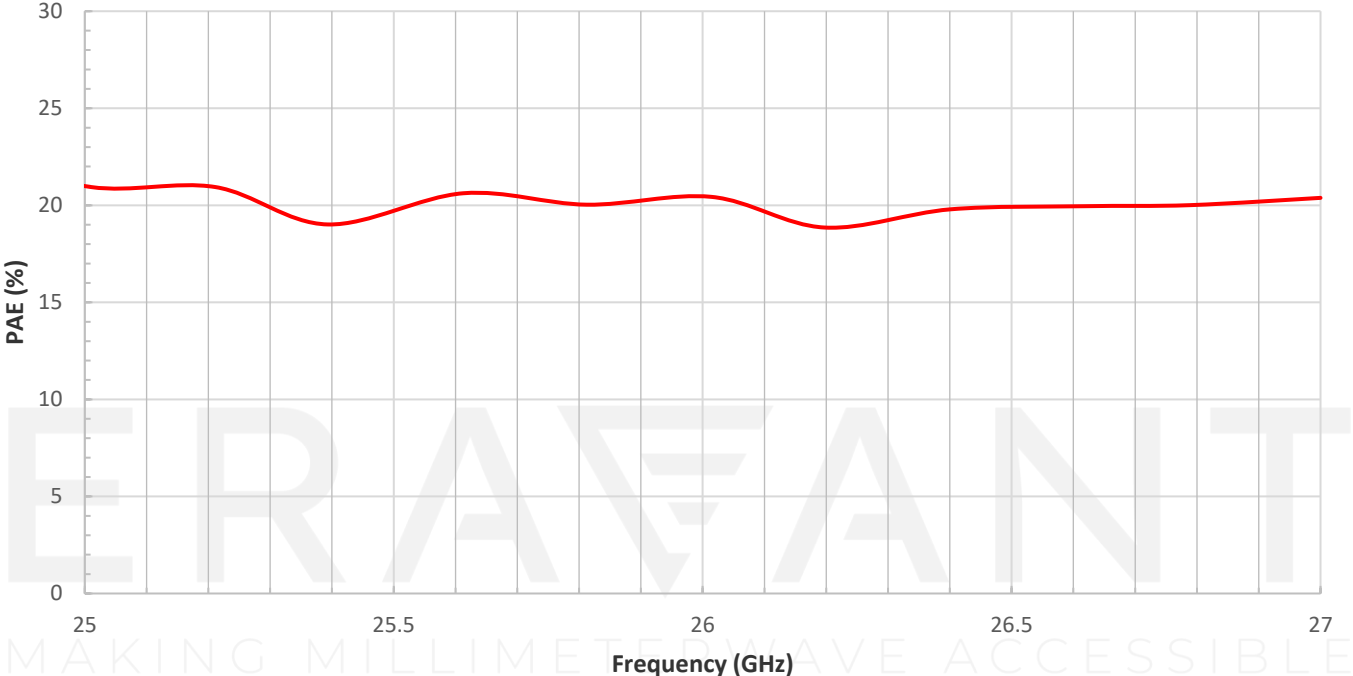

Typical Input Return Loss vs. Frequency

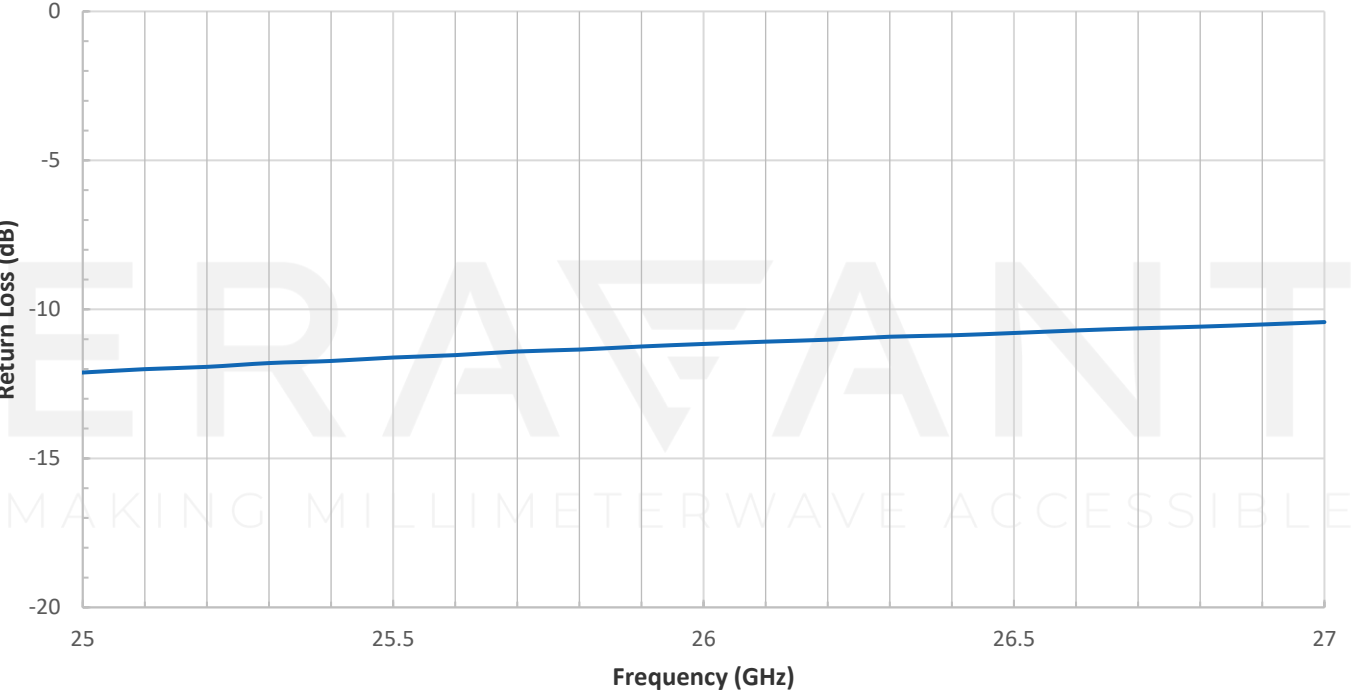

## SBP-2632735143-KFKF-EP

**Mechanical Outline:** (Unless otherwise specified, all dimensions are in inches [millimeters])

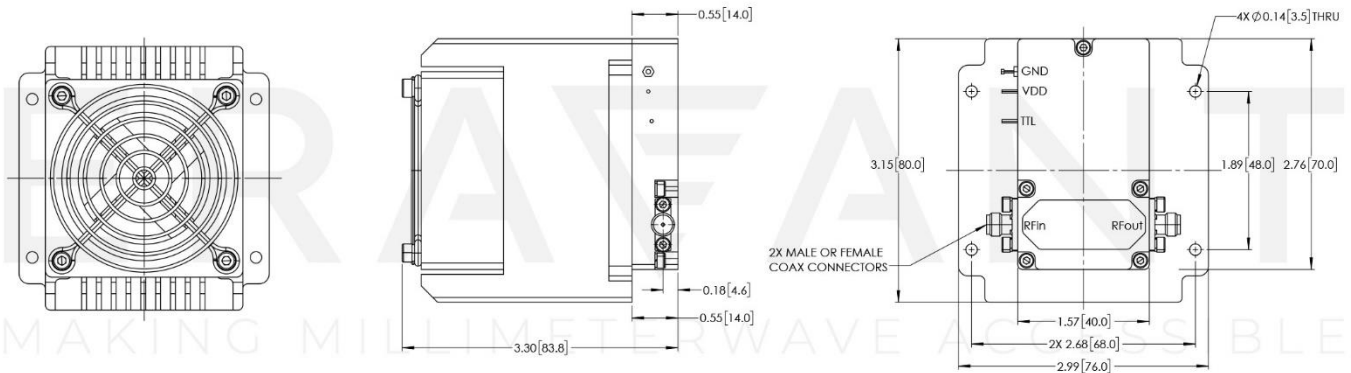

WIRE COLOR	FUNCTIONS
RED	+12V
BLACK	GND
YELLOW	TACH SIGNAL (OPTIONAL)
BLUE	PWM (OPTIONAL)

### OPERATION INSTRUCTIONS:

1. Connect the main power supply (refer to DC supply voltage spec for voltage value) positive lead to VDD Pin and negative lead to GND
2. Connect a +3.3Vdc to +5Vdc power supply positive lead to the TTL pin and the negative pin to GND
3. Turn on the main power supply for VDD
4. Turn on the +3.3 Vdc to +5Vdc power supply to switch TTL "high."
5. The module is now turned on, and input RF power may be applied

### NOTE:

- All data presented is collected from a sample lot. Actual data may vary unit to unit.
- All testing was performed under +25 °C case temperature.
- Other mechanical configurations are available under different model numbers.
- Eravant reserves the right to change the information presented without notice.
- TTL "Low" refers to a voltage range of 0 to 2.1V, while TTL "High" refers to a voltage range of 3.3 to 5V.

### CAUTION:

- Exceeding absolute maximum ratings shown will damage the device.
- Do not block the air inlets and outlets.
- The device is static sensitive. Always follow ESD rules when working with the device.
- Do not plug or unplug any connectors when amplifier is activated. All connectors must be connected/disconnected when amplifier is off.
- The case temperature of the device shall never exceed +50 °C. Use proper heatsink or fan if necessary
- Any foreign objects in the waveguide will degrade performance and/or damage the device.
- Proper torque should be applied:  $8.0 \pm 0.15$  inch-pounds ( $0.90 \pm 0.02$  Nm). Torque wrench model [SCH-08008-S1](#) is highly recommended.