

SBP-0731334044-SFSF-EP

7 to 13 GHz Power Amplifier, 40 dB Gain, +44 dBm P_{sat}

SBP-0731334044-SFSF-EP is a power amplifier with a typical small gain of 40 dB and a nominal P_{sat} of +44 dBm across the frequency range of 7 to 13 GHz. The DC power requirement for the amplifier is +28 V_{DC}/6 A and is enabled or disabled via TTL input. The mechanical configurations is an inline structure with SMA(F) connector as its input port and output port. Other port configurations, such as SMA(M) connectors for either the input or output port, are also available under different model numbers.



Electrical Specifications:

Parameter	Minimum	Typical	Maximum
Frequency	7 GHz		13 GHz
Small Signal Gain		40 dB	
Power Gain		30 dB	
P _{sat}		+44 dBm	
P _{in}			+18 dBm
Input Return Loss		10 dB	
Output Return Loss		5 dB	
Off / On Control	TTL "Low"		TTL "High"
DC Supply Voltage (VDD)	+26 V _{DC}	+28 V _{DC}	+30 V _{DC}
DC Supply Current		6 A	
Supply Voltage to Fan		+12 V _{DC} /1.8 A	
Specification Temperature		+25 °C	
Operating Temperature	0 °C		+50 °C

Mechanical Specifications:

Item	Specification
Input	SMA Female
Output	SMA Female
Power Supply/TTL	Solder Pin
Case Material	Copper
Finish	Gold Plated
Size	2.99" (L) X 3.15" (W) X 3.30" (H)
Outline	BP-HC-H3

ECCN

EAR99

FEATURES

- Class AB GaN Technique
- Broadband Performance
- High Gain
- High Output Power
- TTL Control

APPLICATIONS

- Radar Systems
- Communication Systems
- Test Equipment

SUPPLEMENTAL DETAILS



Typical Return Loss vs. Frequency

Bias: +28V_{DC}/1211 mA

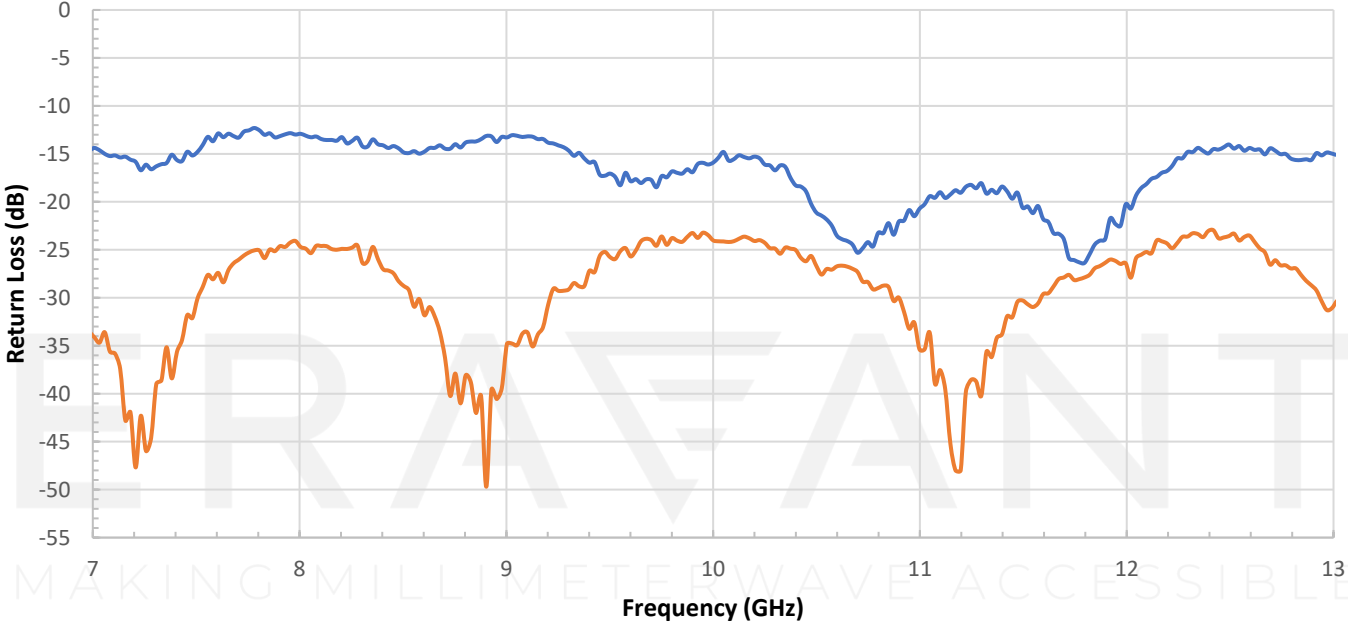

Typical Psat vs. Frequency

Bias: +28V_{DC}/4780 mA

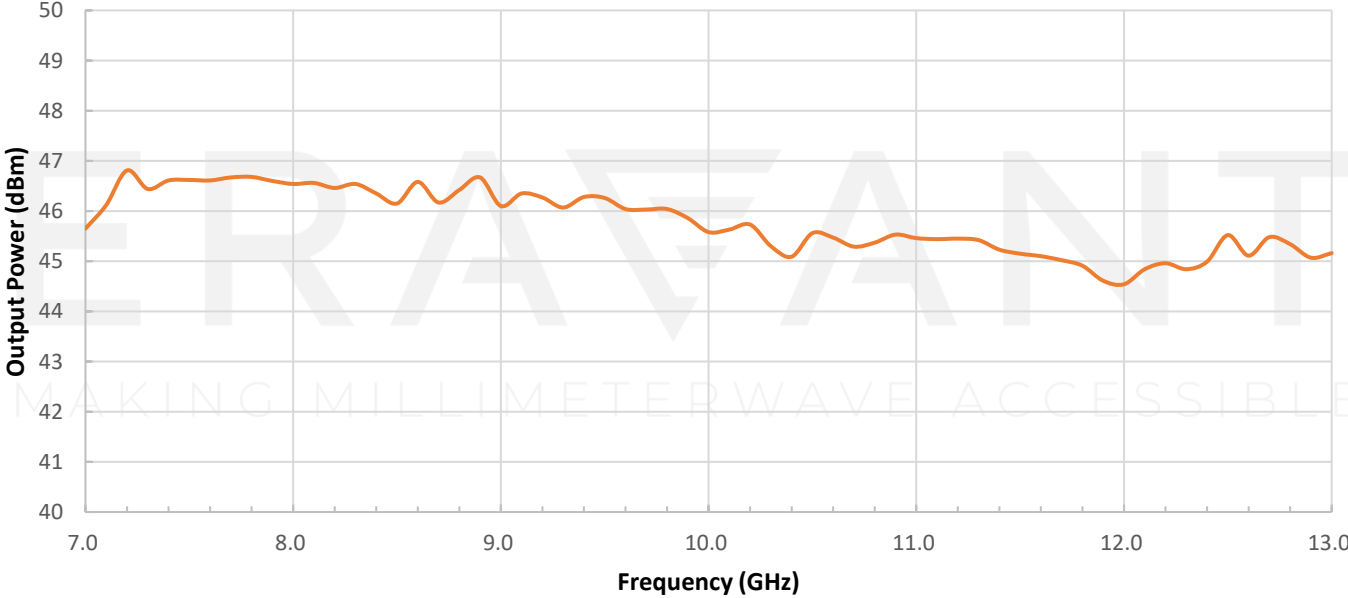

Typical PAE vs. Frequency

Bias: +28V_{DC}/4780 mA

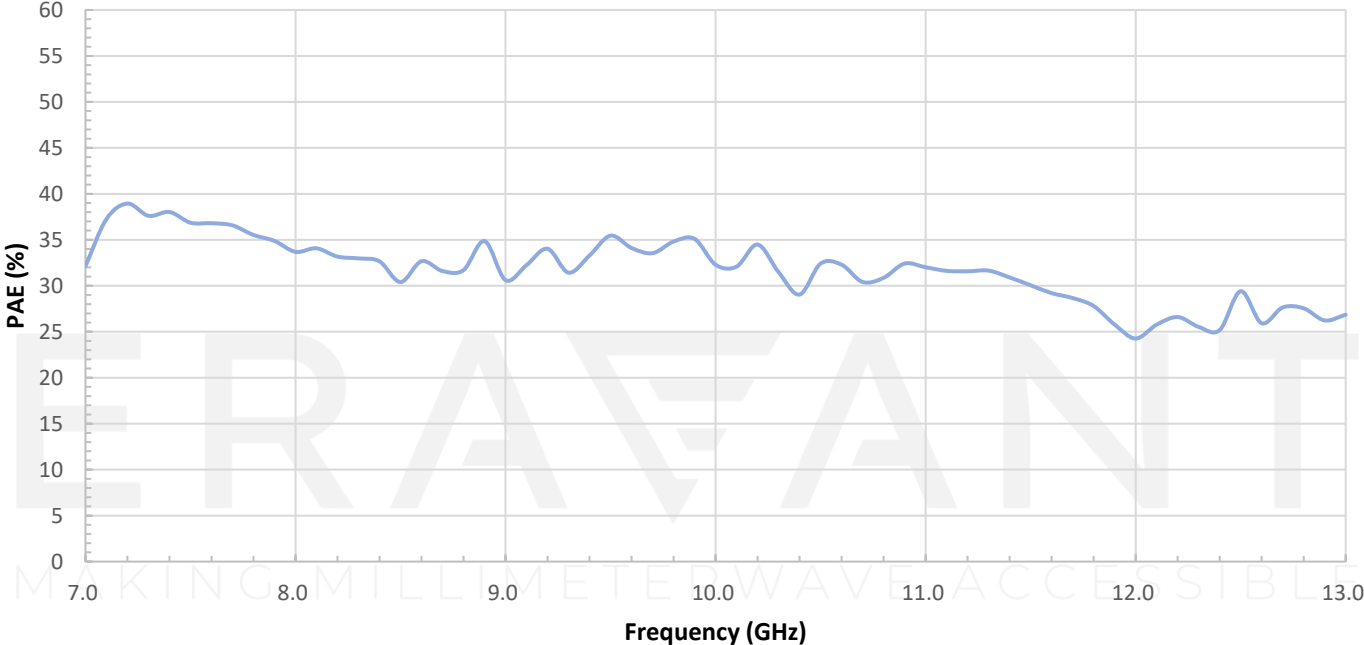

SBP-0731334044-SFSF-EP

Mechanical Outline: (Unless otherwise specified, all dimensions are in inches [millimeters])

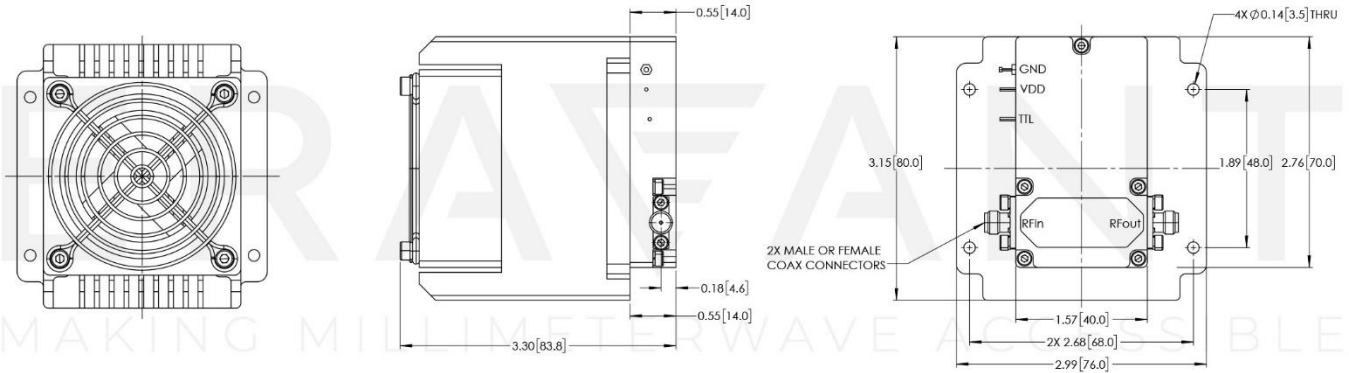

WIRE COLOR	FUNCTIONS
RED	+12V
BLACK	GND
YELLOW	TACH SIGNAL (OPTIONAL)
BLUE	PWM (OPTIONAL)

OPERATION INSTRUCTIONS:

1. Connect the main power supply (refer to DC supply voltage spec for voltage value) positive lead to VDD Pin and negative lead to GND
2. Connect a +3.3Vdc to +5Vdc power supply positive lead to the TTL pin and the negative pin to GND
3. Turn on the main power supply for VDD
4. Turn on the +3.3 Vdc to +5Vdc power supply to switch TTL "high."
5. The module is now turned on, and input RF power may be applied

NOTE:

- All data presented is collected from a sample lot. Actual data may vary unit to unit.
- All testing was performed under +25 °C case temperature.
- Other mechanical configurations are available under different model numbers.
- Eravant reserves the right to change the information presented without notice.
- TTL "Low" refers to a voltage range of 0 to 2.1V, while TTL "High" refers to a voltage range of 3.3 to 5V.

CAUTION:

- Exceeding absolute maximum ratings shown will damage the device.
- Do not block the air inlets and outlets.
- The device is static sensitive. Always follow ESD rules when working with the device.
- Do not plug or unplug any connectors when amplifier is activated. All connectors must be connected/disconnected when amplifier is off.
- The case temperature of the device shall never exceed +50 °C. Use proper heatsink or fan if necessary
- Proper torque should be applied: 8.0 ± 0.15 inch-pounds (0.90 ± 0.02 Nm). Torque wrench model SCH-08008-S1 is highly recommended.