



WR-22 Standard Gain Horn Antenna, 24 dBi Gain

Description:

Model SAZ-2410-22-S1 is a Q-band standard gain horn antenna that operates from 33 GHz to 50 GHz. The antenna offers 24 dBi nominal gain, a typical half power beamwidth of 9.7 degrees on the E-plane and 11.1 degrees on the H-plane at the center frequency, respectively. The antenna supports linear polarized waveforms. The input of this antenna is a WR-22 waveguide with UG-383/U flange. The standard gain horn is offered for antenna range calibration purpose mainly, but it can be also used for general purpose system set ups.



Features:

- Rectangular Waveguide Interface
- Precisely Machined and Gold Plated
- Linear Polarization
- High Return Loss

Applications:

- Antenna Range
- Antenna Gain Measurements
- General System Setups
- Radar/Communication Systems

Electrical Specifications:

Parameter	Minimum	Typical	Maximum
Frequency	33 GHz		50 GHz
Gain		24 dBi	
Polarization		Linear	
3 dB Beamwidth, E-Plane @41.5GHz		9.7°	
3 dB Beamwidth, H-Plane @41.5GHz		11.1°	
Sidelobes, E-Plane		-13 dB	
Sidelobes, H-Plane		-36 dB	
Return Loss		23 dB	
Specification Temperature		+25 °C	
Operation Temperature	-40 °C		+85 °C

Mechanical Specifications:

Item	Specification
Antenna Port	WR-22 Waveguide
Flange Type	UG-383/U Flange
Material	Brass
Finish	Gold Plated
Weight	5.78 Oz
Size	4.60" (L) X 2.09" (W) X 1.69" (H)
Outline	AZ-Q24





WR-22 Standard Gain Horn Antenna, 24 dBi Gain

Typical Antenna Patterns @ 41 GHz

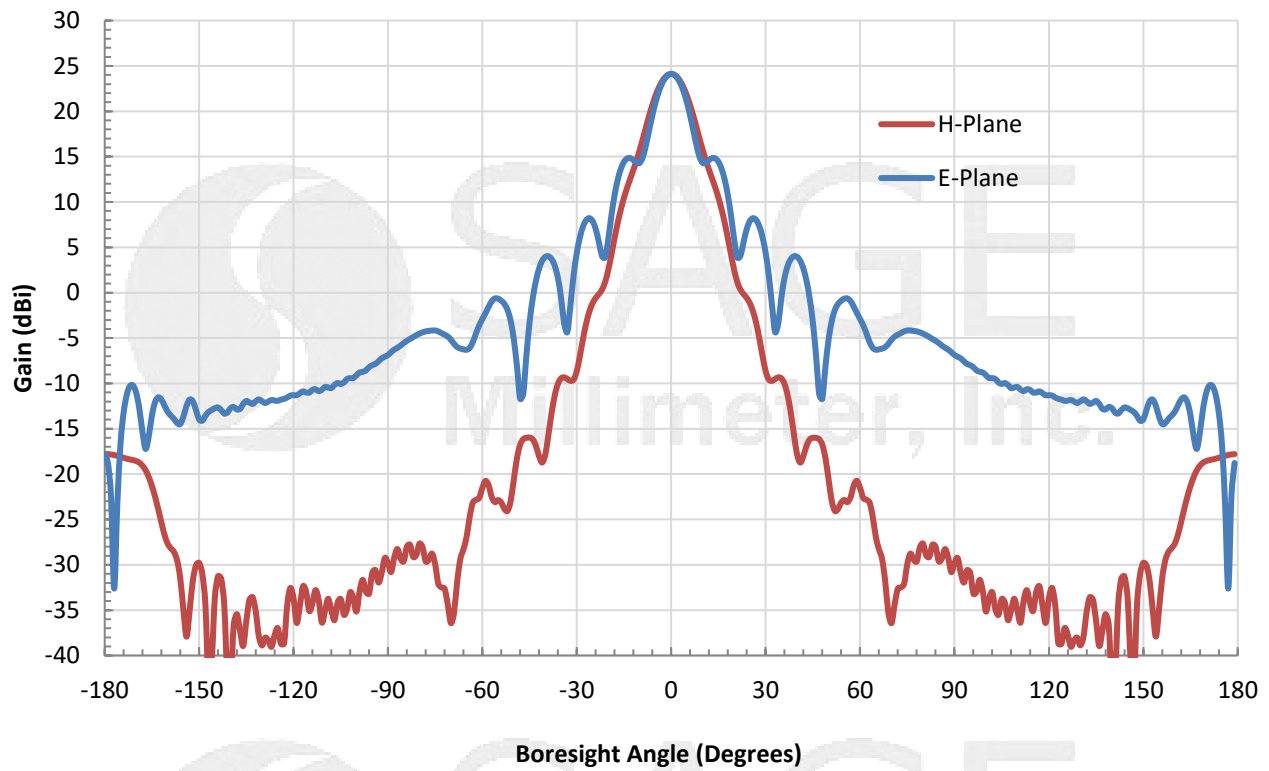

Typical Gain vs. Frequency

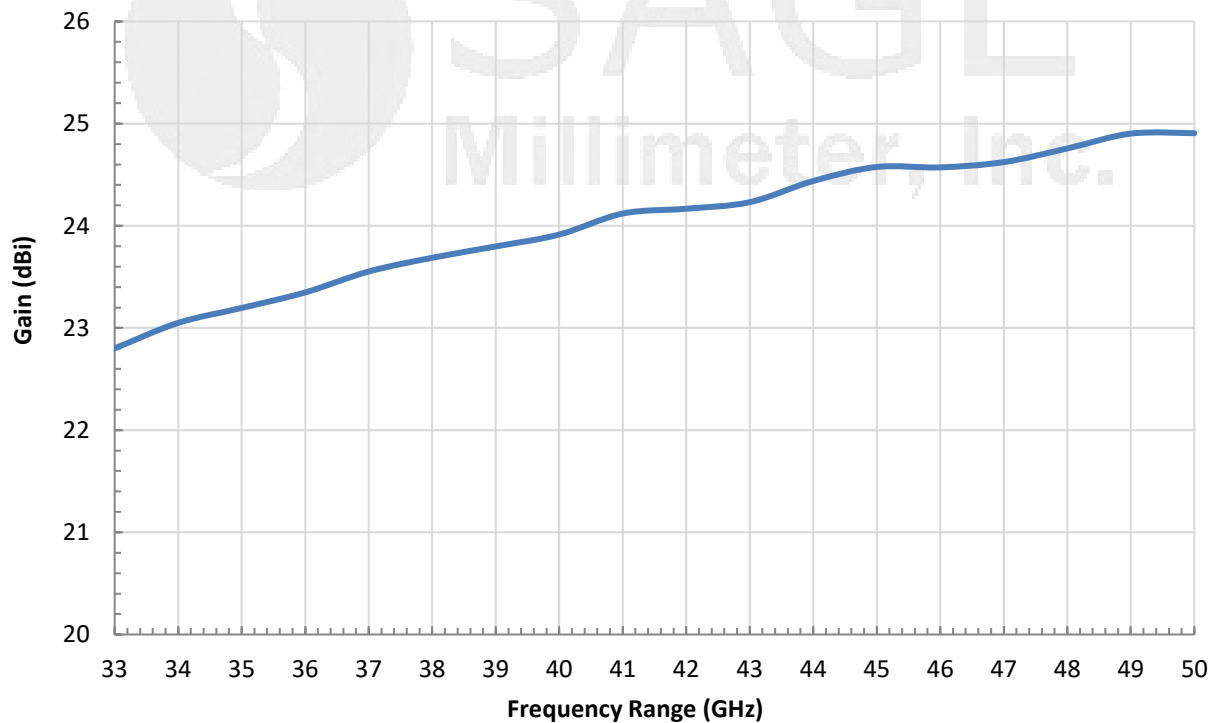



WR-22 Standard Gain Horn Antenna, 24 dBi Gain

Simulated Gain vs. Frequency in Tabular Format

Frequency (GHz)	Gain (dBi)	Frequency (GHz)	Gain (dBi)
33	22.8	42	24.2
34	23.1	43	24.2
35	23.2	44	24.4
36	23.4	45	24.6
37	23.6	46	24.6
38	23.7	47	24.6
39	23.8	48	24.8
40	23.9	49	24.9
41	24.1	50	24.9

Simulated Half Power Beamwidth (H-Plane) vs. Frequency in Tabular Format

Frequency (GHz)	Beamwidth (Degrees)	Frequency (GHz)	Beamwidth (Degrees)
33	12.7	42	10.9
34	12.4	43	10.7
35	12.0	44	10.5
36	11.8	45	10.4
37	11.6	46	10.4
38	11.5	47	10.3
39	11.3	48	10.1
40	11.1	49	9.8
41	11.0	50	9.6

Simulated Half Power Beamwidth (E-Plane) vs. Frequency in Tabular Format

Frequency (GHz)	Beamwidth (Degrees)	Frequency (GHz)	Beamwidth (Degrees)
33	11.3	42	9.3
34	11.1	43	8.8
35	10.9	44	8.3
36	10.7	45	8.1
37	10.5	46	8.1
38	10.4	47	7.6
39	10.2	48	7.4
40	9.9	49	7.2
41	9.4	50	7.2



WR-22 Standard Gain Horn Antenna, 24 dBi Gain

Mechanical Outline: (Unless otherwise specified, all dimensions are in inches [millimeters])

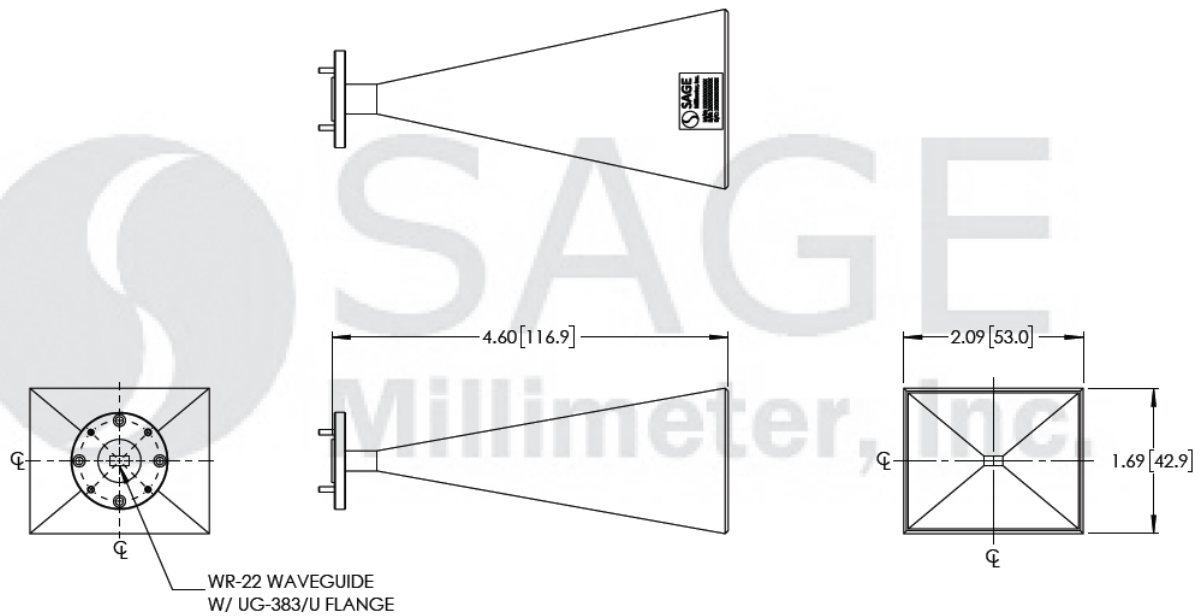
**Note:**

- All data presented is simulated by a full EM simulator. Eravant recommends using simulated data over measured for standard gain horn antenna for accuracy. See Blog [here](#) for further information.
- The antenna electrical performance is guaranteed through accurate mechanical tolerance control. Each antenna is examined by CMM (coordinate Measuring Machine) inspection and measurement process.
- A calibration certificate can be issued with a fee under part number FTA-0150-S1-SAZ.
- Eravant reserves the right to change the information presented without notice.

Caution:

- Any foreign objects in the antenna will cause performance degradation and possible device damage.

