



Linear to Circular Polarizer, Q Band, 39 to 41 GHz, Ø 0.219"

Description:

Model SAS-403-21922-F1 is a Q band, linear to circular polarizer that operates at 40 GHz with a ± 1.0 GHz bandwidth. The polarizer offers a typical insertion loss of 0.5 dB, a typical axial ratio of 1.1, and a typical return loss of 20 dB. The polarizer is fixed and can be used for either right-handed or left-handed polarization based on the direction of the input signal. The polarizer is often combined with Eravant's rectangular to circular waveguide transition (**SWT-22219-SB**) and WR-22 conical horn antenna (**SAC-2309-219-S2**) for various system applications.



Features:

- Circular Waveguide Interface
- Low Insertion Loss
- Good Axial Ratio
- LHCP or RHCP

Applications:

- Antenna Ranges
- Waveguide polarization selection
- Radar Systems
- Communication Systems

Electrical Specifications:

Parameter	Minimum	Typical	Maximum
Frequency*	39 GHz		41 GHz
Insertion Loss		0.5 dB	
Axial Ratio		1.1	
Return Loss		20 dB	
Specification Temperature		+25 °C	
Operating Temperature	-40 °C		+85 °C

*Note: Actual frequency can be extended to cover 39 to 43 GHz.

Mechanical Specifications:

Item	Specification
Waveguide	0.219" Dia Circular Waveguide with UG-383/U-M Flange
Body Material	Brass
Finish	Gold Plated
Weight	2.5 Oz
Insertion Length	1.5"
Outline	AS-FQB-219





Linear to Circular Polarizer, Q Band, 39 to 41 GHz, Ø 0.219"

Measured Insertion Loss vs. Frequency

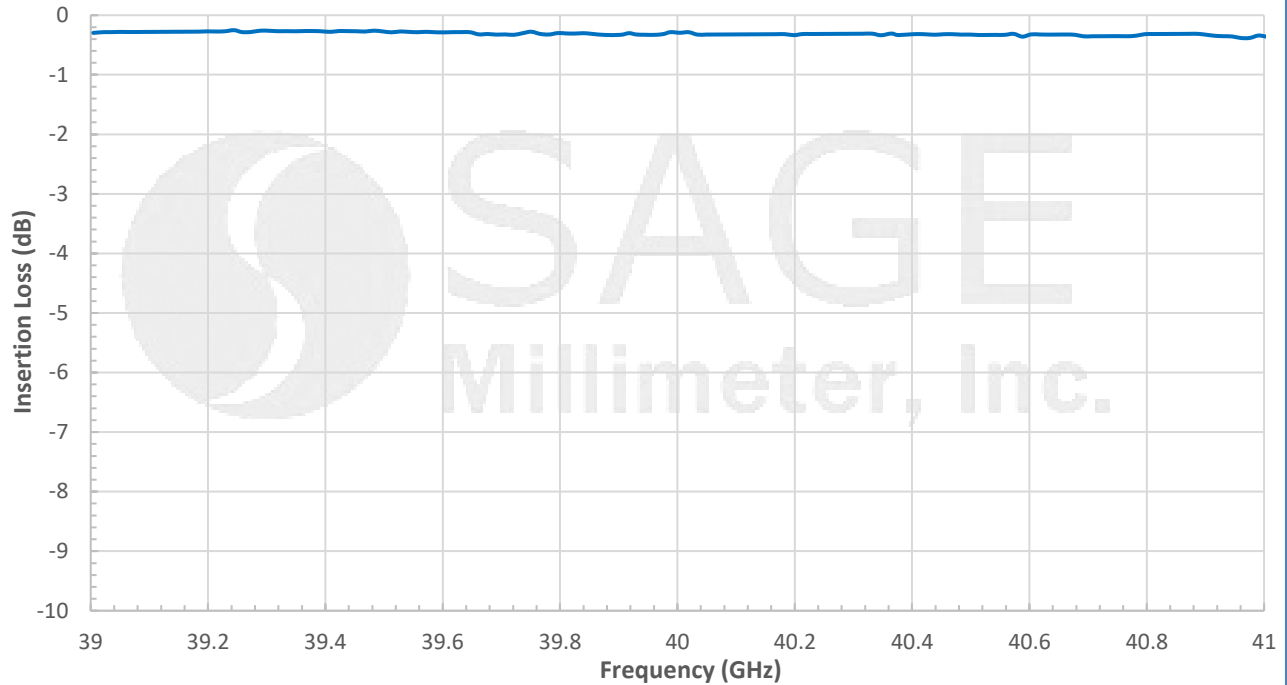

Mechanical Outline: (Unless otherwise specified, all dimensions are in inches [millimeters])

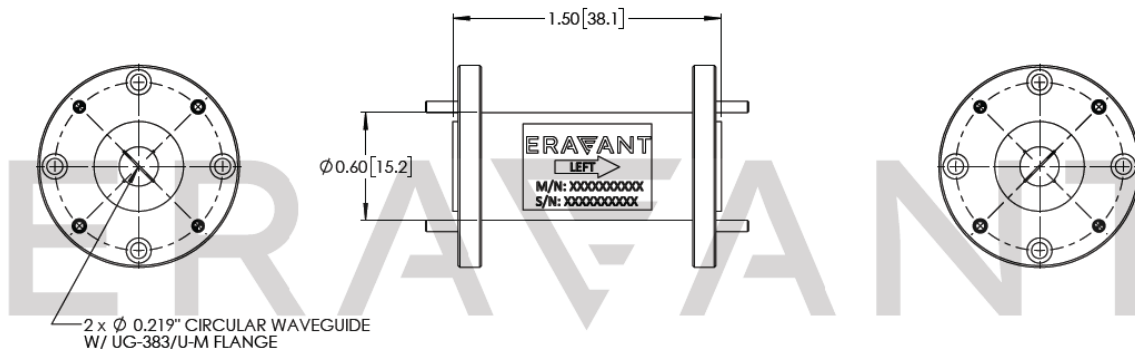

Note:

- All data presented is collected from a sample lot. Actual data may vary unit to unit, slightly.
- The Polarizer is offered as LHCP. However, it can be used as RHCP by reversing the input and output ports.
- Eravant reserves the right to change the information presented without notice.

Caution:

- Any foreign objects in the antenna will cause performance degradation and possible device damage.





Linear to Circular Polarizer, Q Band, 39 to 41 GHz, Ø 0.219"

LHCP and RHCP Polarization Configuration Notes and Diagram:

- The polarizer's product label indicates the direction of **Left-Handed Circular Polarization (LHCP)**.
- An example configuration diagram is provided below. The diagram indicates the input and output ports and the orientation in which the polarizer is to be attached to the rest of the components to obtain a **LHCP** signal at the output port.
- The polarizer can be configured to obtain a **Right-Handed Circular Polarized (RHCP)** signal at the output port by reversing the input and output ports as shown in the second diagram.

