



WR-28 Pyramidal Horn Antenna, 25 dBi Gain

Description:

Model SAR-2507-28-S2 is a Ka-band pyramidal horn antenna that operates from 26.5 GHz to 40 GHz. The antenna offers 25 dBi nominal gain and a typical half power beamwidth of 7 degrees on the E-plane and 9 degrees on the H-plane. The antenna supports linear polarized waveforms. The input of this antenna is a WR-28 waveguide with UG-599/U flange.



Features:

- Rectangular Waveguide Interface
- Precisely Machined
- Linear Polarization
- High Return Loss

Applications:

- Antenna Ranges
- Antenna Gain Measurements
- System Setups

Electrical Specifications:

Parameter	Minimum	Typical	Maximum
Frequency	26.5 GHz		40 GHz
Gain	23.5 dBi	25 dBi	26 dBi
Polarization	Linear		
3 dB Beamwidth, E-Plane		7°	
3 dB Beamwidth, H-Plane		9°	
Sidelobes, E-Plane		-14 dB	
Sidelobes, H-Plane		-30 dB	
Return Loss		23 dB	
Specification Temperature		+25 °C	
Operation Temperature	-40 °C		+85 °C

Mechanical Specifications:

Item	Specification
Antenna Port	WR-28 Waveguide
Flange Type	UG-599/U Flange
Size	6.91" (L) X 2.88" (W) X 2.31" (H)
Material	Aluminum
Finish	Gold Plated
Weight	2.5 Oz
Outline	AR-A3



www.ervant.com | 501 Amapola Ave, Torrance, CA 90501
 Phone: 424-757-0168 | Fax: 424-757-0188 | Email: support@ervant.com



WR-28 Pyramidal Horn Antenna, 25 dBi Gain

Simulated Antenna Patterns @ 26.5 GHz

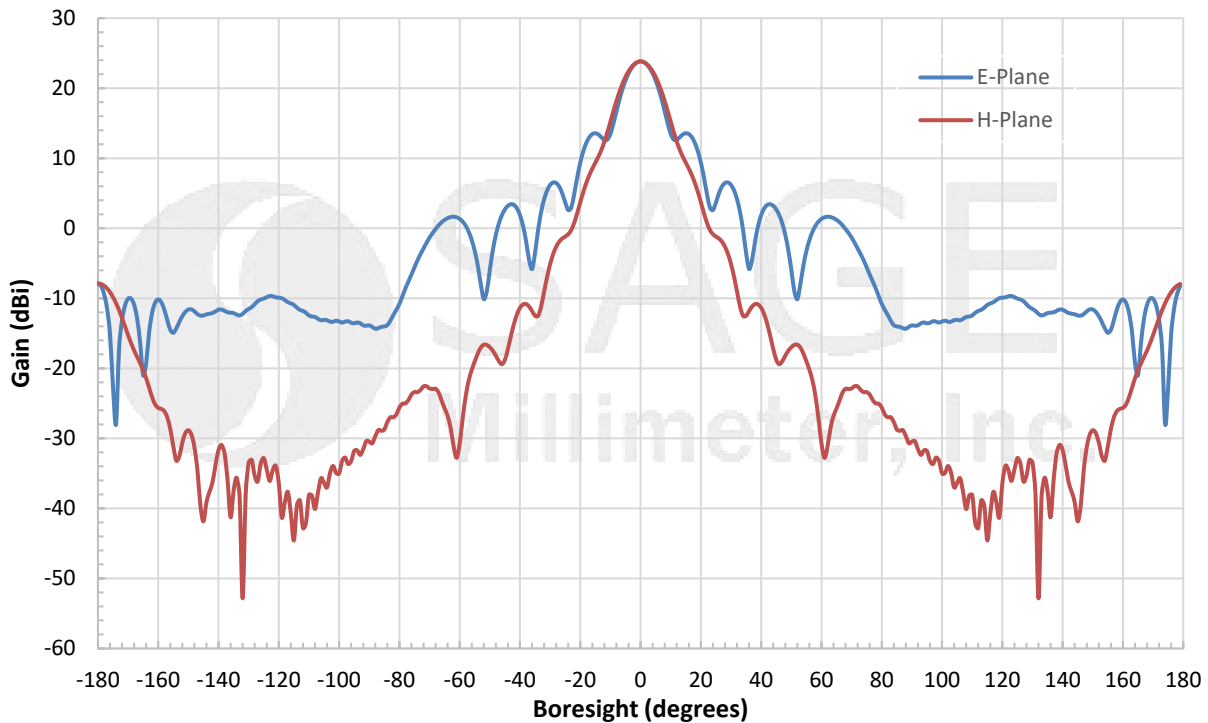

Simulated Antenna Patterns @ 33.5 GHz

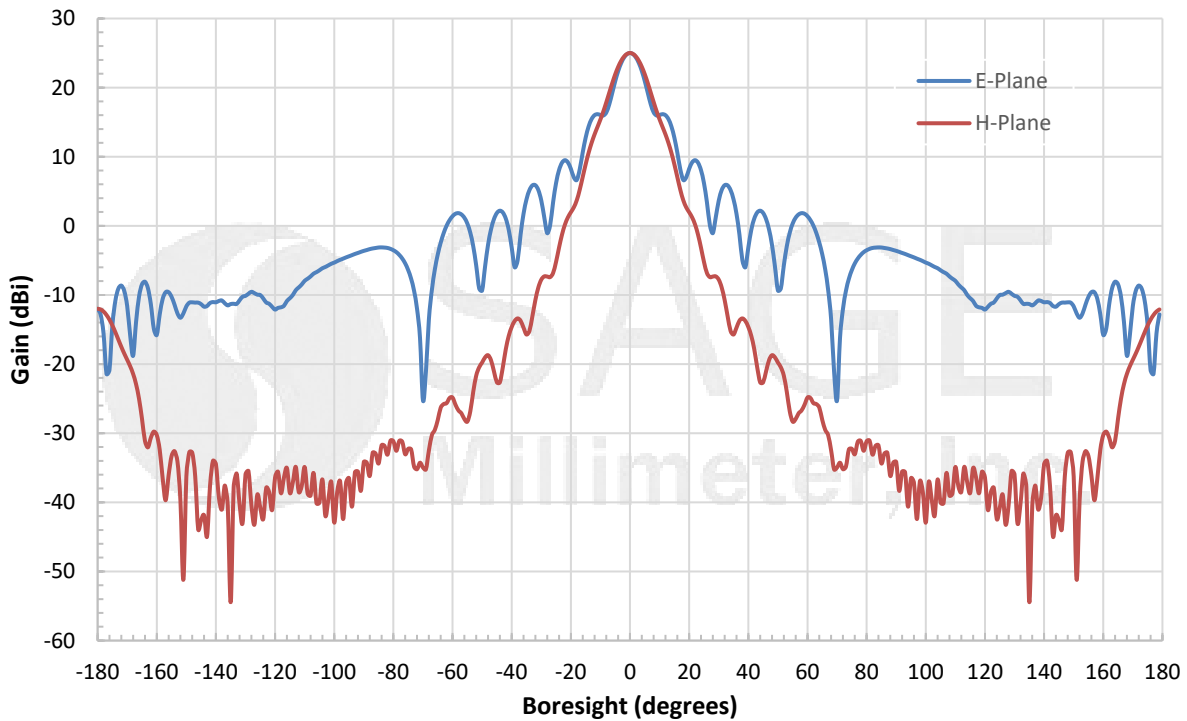

www.eravant.com | 501 Amapola Ave, Torrance, CA 90501
Phone: 424-757-0168 | Fax: 424-757-0188 | Email: support@eravant.com



WR-28 Pyramidal Horn Antenna, 25 dBi Gain

Simulated Antenna Patterns @ 40 GHz

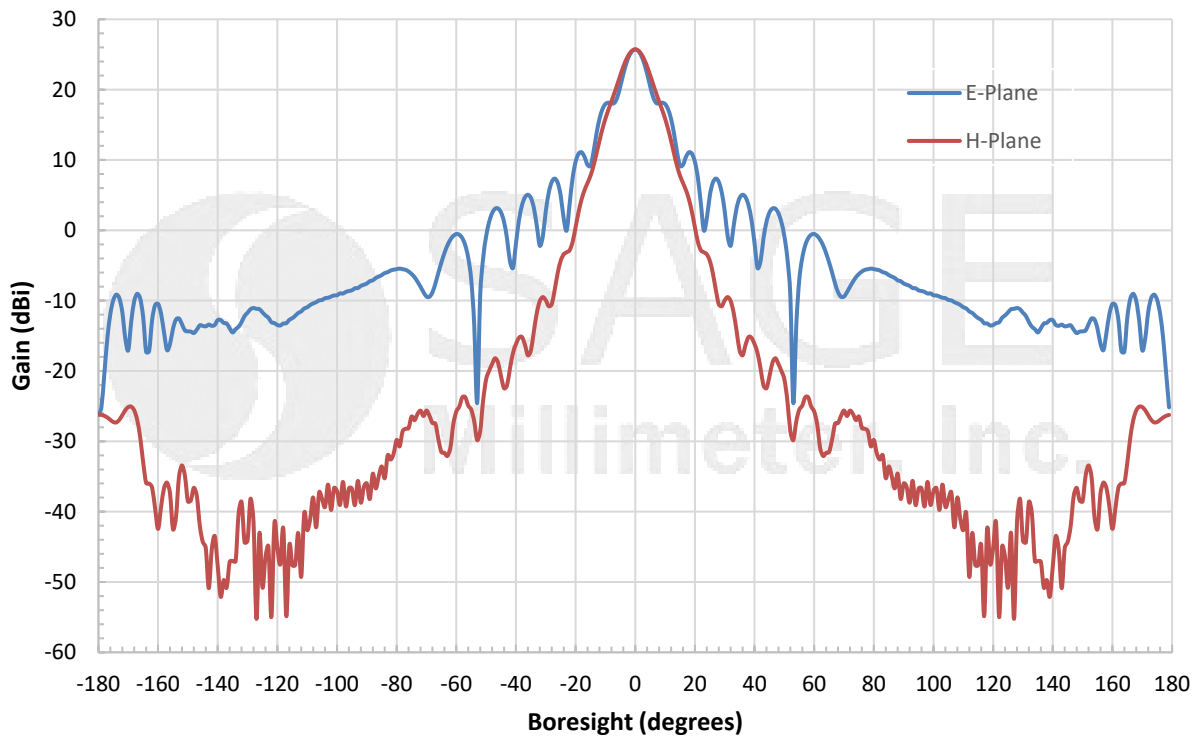

Simulated Return Loss vs. Frequency

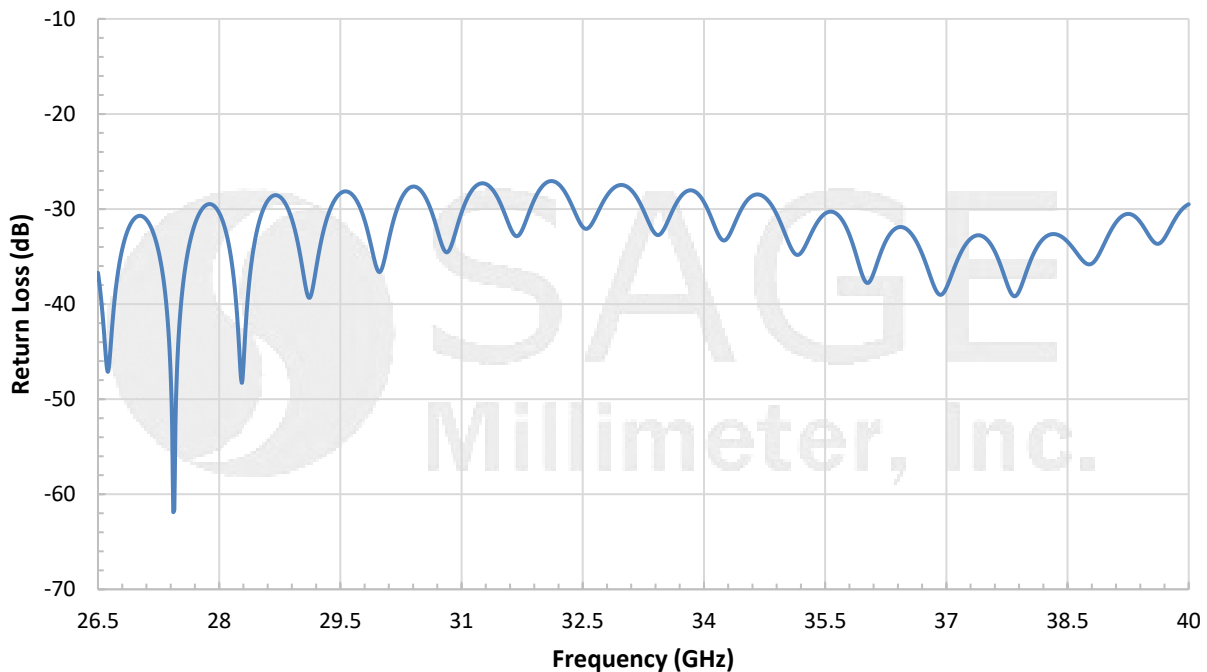

www.eravant.com | 501 Amapola Ave, Torrance, CA 90501
Phone: 424-757-0168 | Fax: 424-757-0188 | Email: support@eravant.com



WR-28 Pyramidal Horn Antenna, 25 dBi Gain

Simulated Gain vs. Frequency

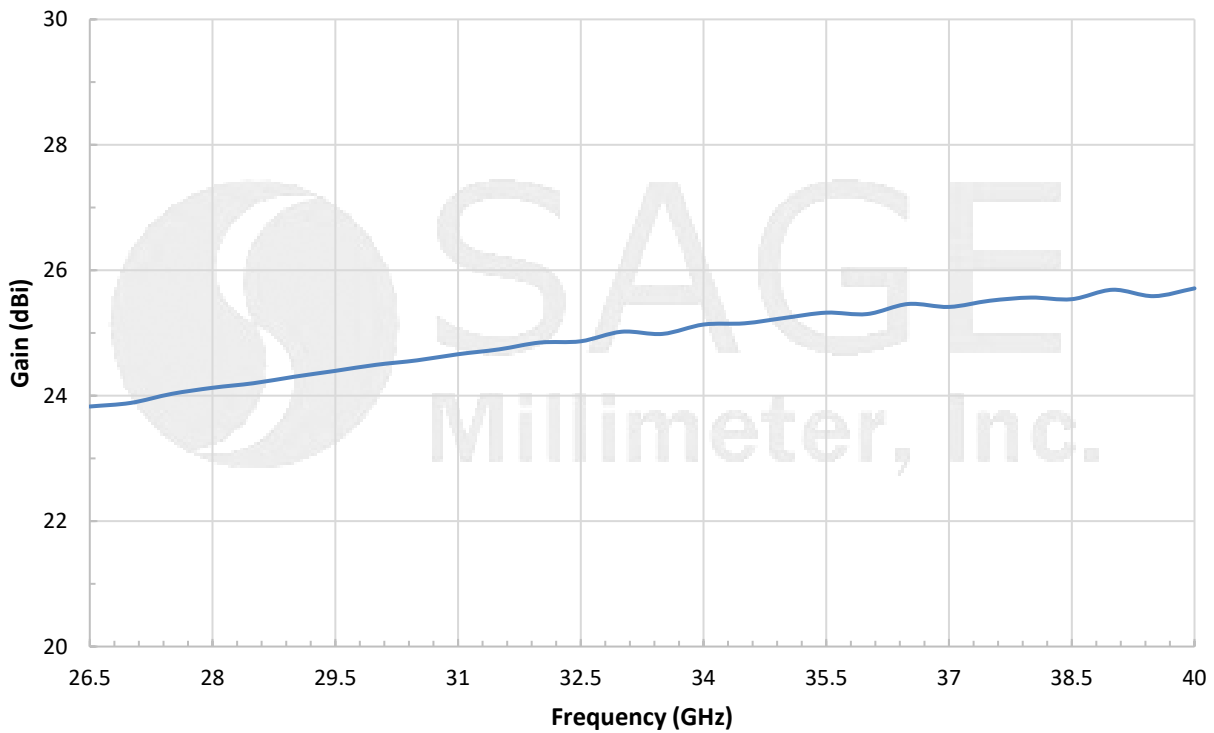

Mechanical Outline: (Unless otherwise specified, all dimensions are in inches [millimeters])

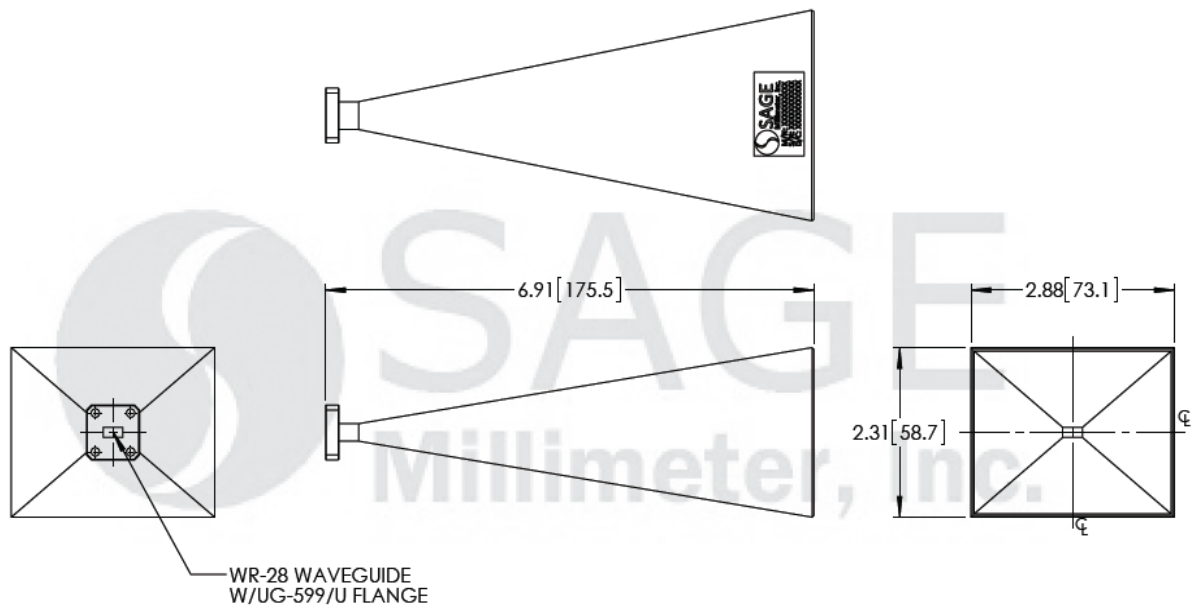

www.eravant.com | 501 Amapola Ave, Torrance, CA 90501
 Phone: 424-757-0168 | Fax: 424-757-0188 | Email: support@eravant.com



WR-28 Pyramidal Horn Antenna, 25 dBi Gain

Note:

- This antenna is a mature product. The reasons for only providing simulated data can be found in the following blog [here](#).
- Eravant reserves the right to change the information presented without notice.

Caution:

- Any foreign objects in the waveguide will cause performance degradation and possible device damage.

