

SAR-2507-12-S2

WR-12 Pyramidal Horn Antenna, 25 dBi Gain

SAR-2507-12-S2 is an E-band pyramidal horn antenna that operates from 60 GHz to 90 GHz. The antenna offers 25 dBi nominal gain and a typical half power beamwidth of 9 degrees on the E-plane and 10 degrees on the H-plane. The antenna supports linear polarized waveforms. The input of this antenna is a WR-12 waveguide with UG-387/U anti-cocking flange.



Electrical Specifications:

Parameter	Minimum	Typical	Maximum
Frequency Range	60 GHz		90 GHz
Gain	23.5 dBi	25 dBi	26 dBi
Polarization		Linear	
3 dB Beamwidth, E-Plane		9°	
3 dB Beamwidth, H-Plane		10°	
Sidelobes, E-Plane		-14 dB	
Sidelobes, H-Plane		-30 dB	
Return Loss		23 dB	
Specification Temperature		+25°C	
Operating Temperature	-40°C		+85°C

Mechanical Specifications:

Item	Specification
Antenna Port	WR-12 Waveguide
Flange Type	UG-387/U Anti-Cocking Flange
Material	Brass
Finish	Gold Plated
Weight	2.12 Oz
Size	3.10" (L) X 1.33" (W) X 1.08"(H)
Outline	AR-E3-A

ECCN

EAR99

FEATURES

- Rectangular Waveguide Interface
- Precisely Machined and Gold Plated
- Linear Polarization
- High Return Loss

APPLICATIONS

- Antenna Ranges
- Antenna Gain Measurements
- System Setups

SUPPLEMENTAL DETAILS



Simulated Antenna Patterns @ 60 GHz

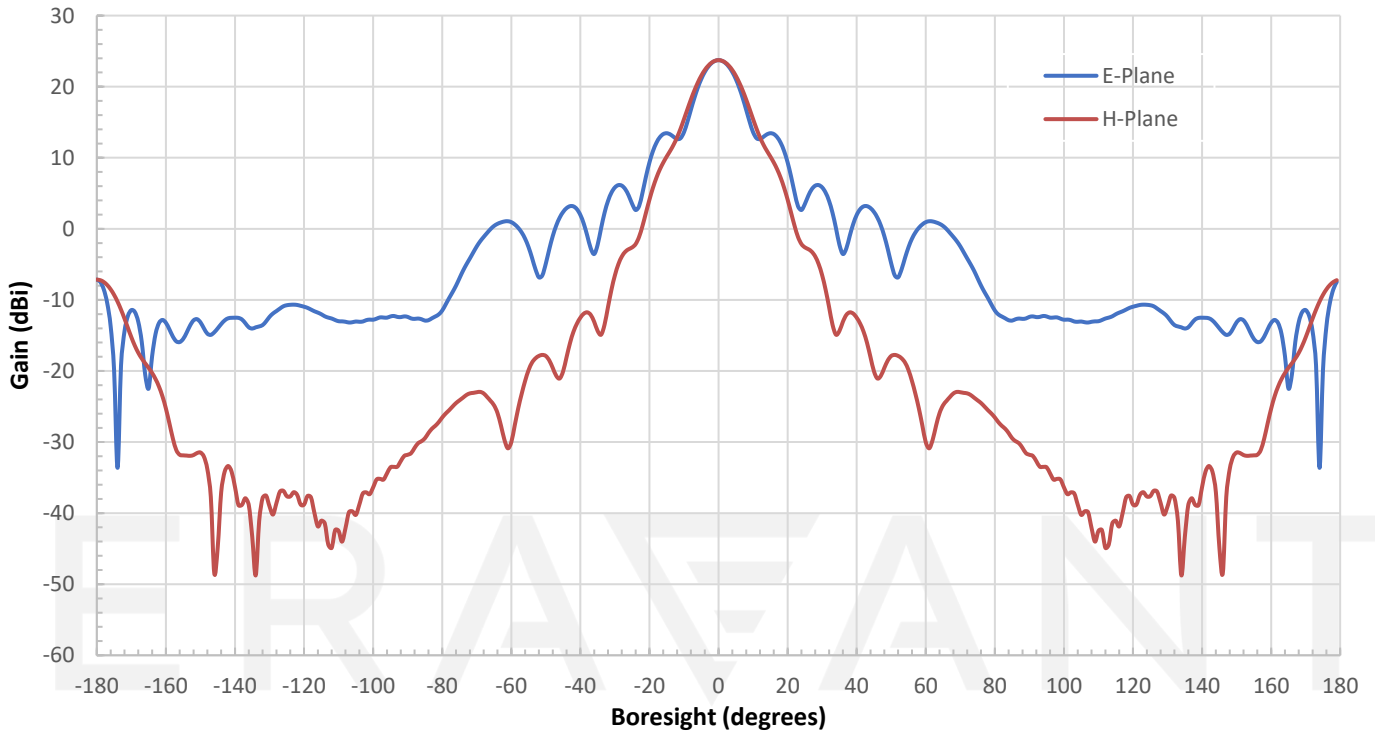

Simulated Antenna Patterns @ 75 GHz

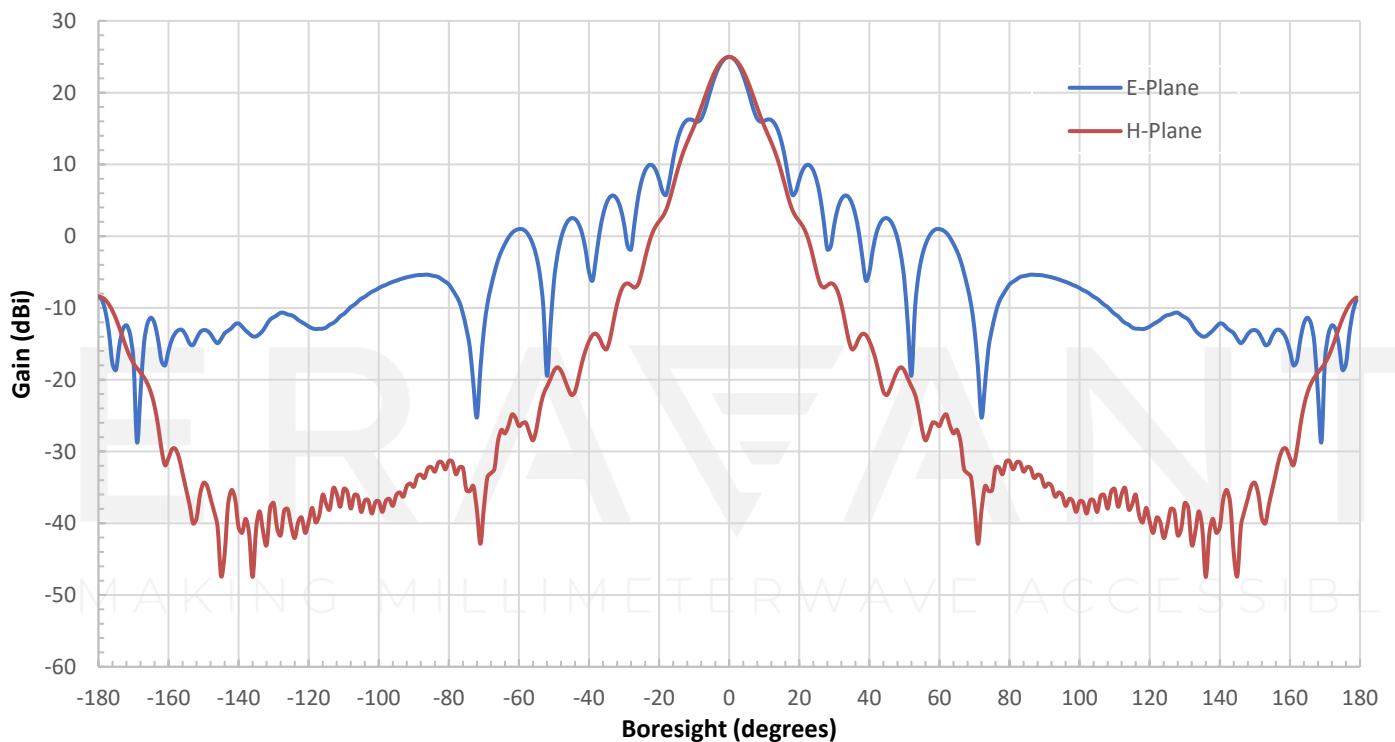

Simulated Antenna Patterns @ 90 GHz

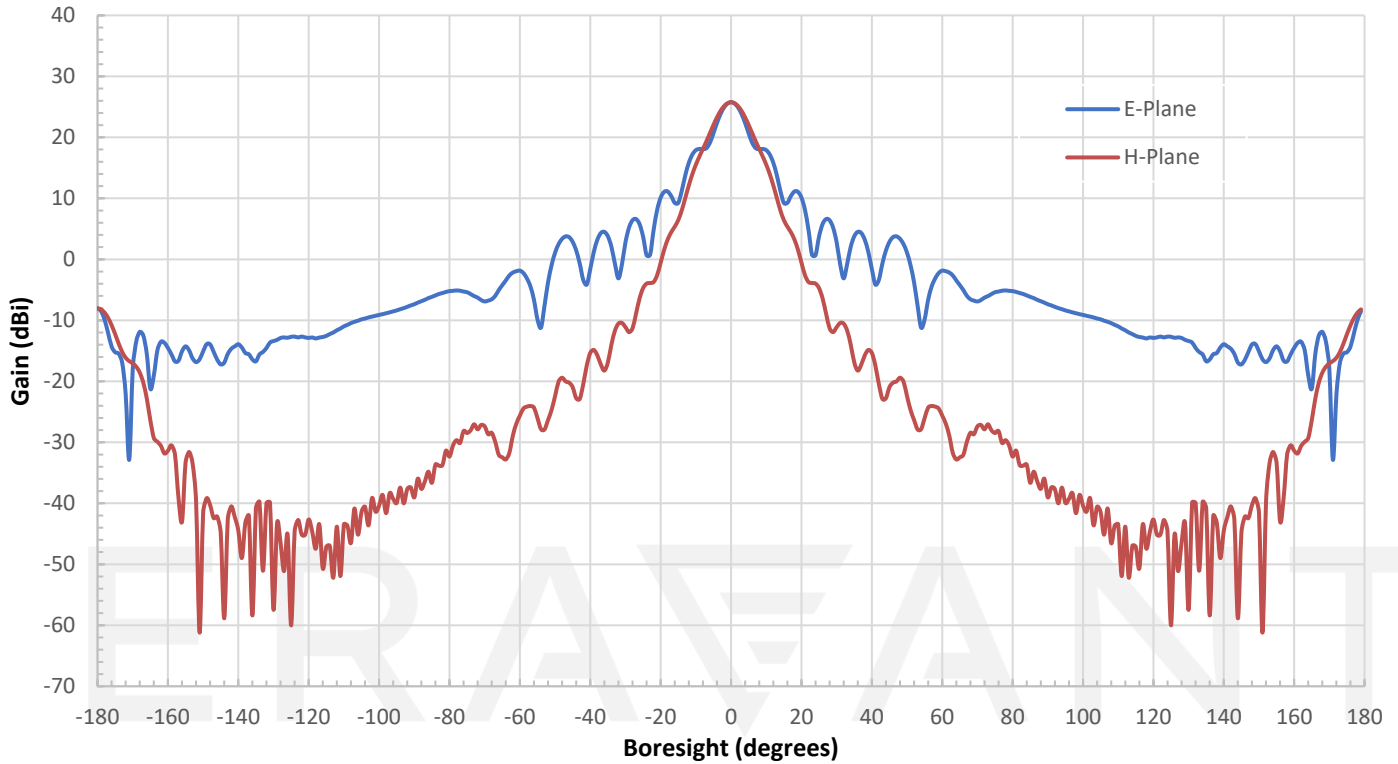

Simulated Return Loss vs. Frequency

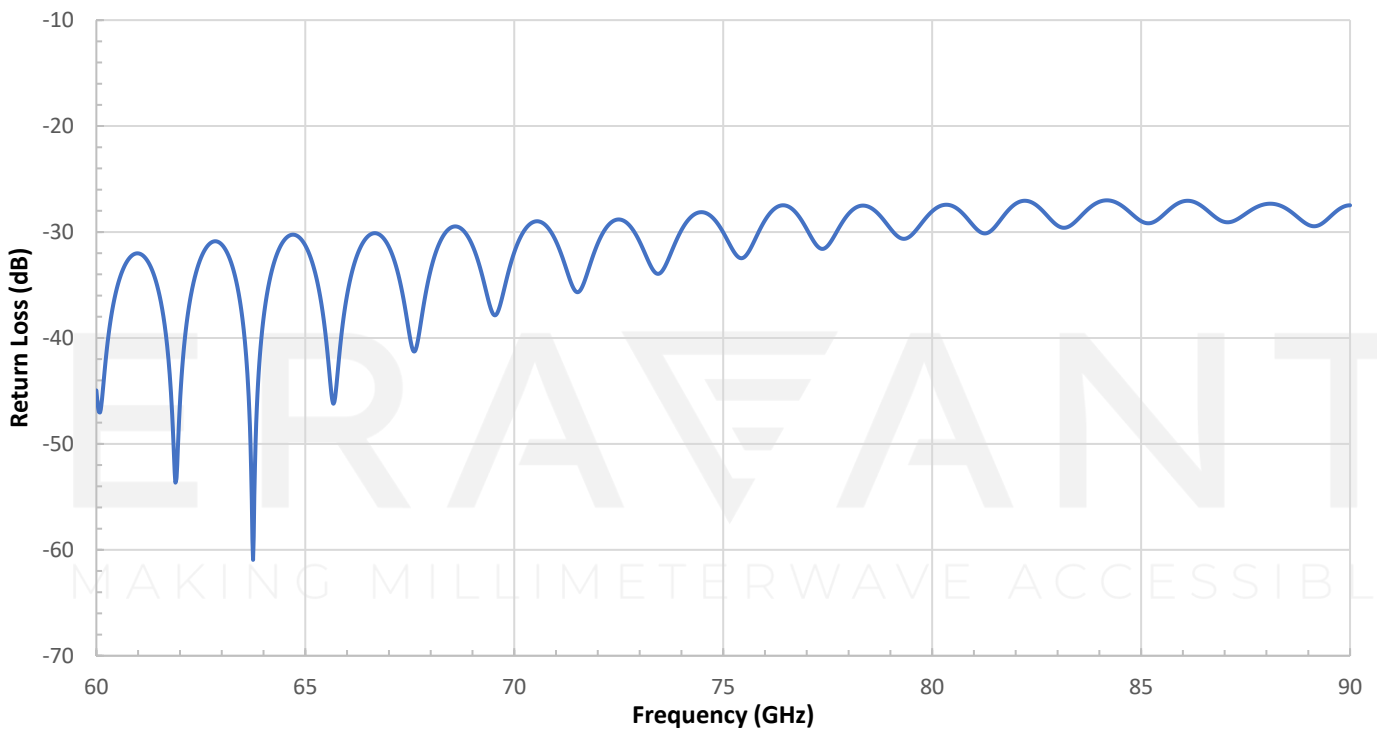

SAR-2507-12-S2

Simulated Gain vs. Frequency

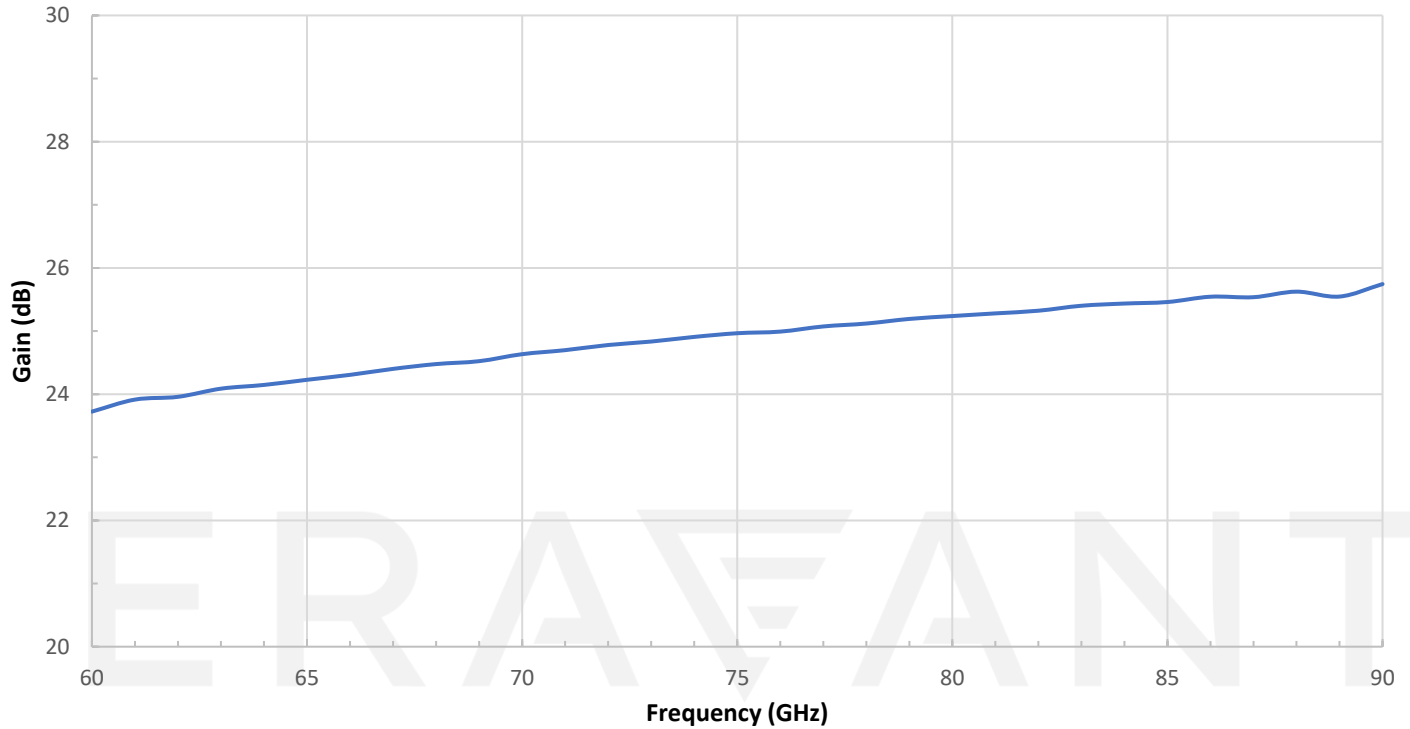

Mechanical Outline: Unless otherwise specified, all dimensions are in inches [millimeters]

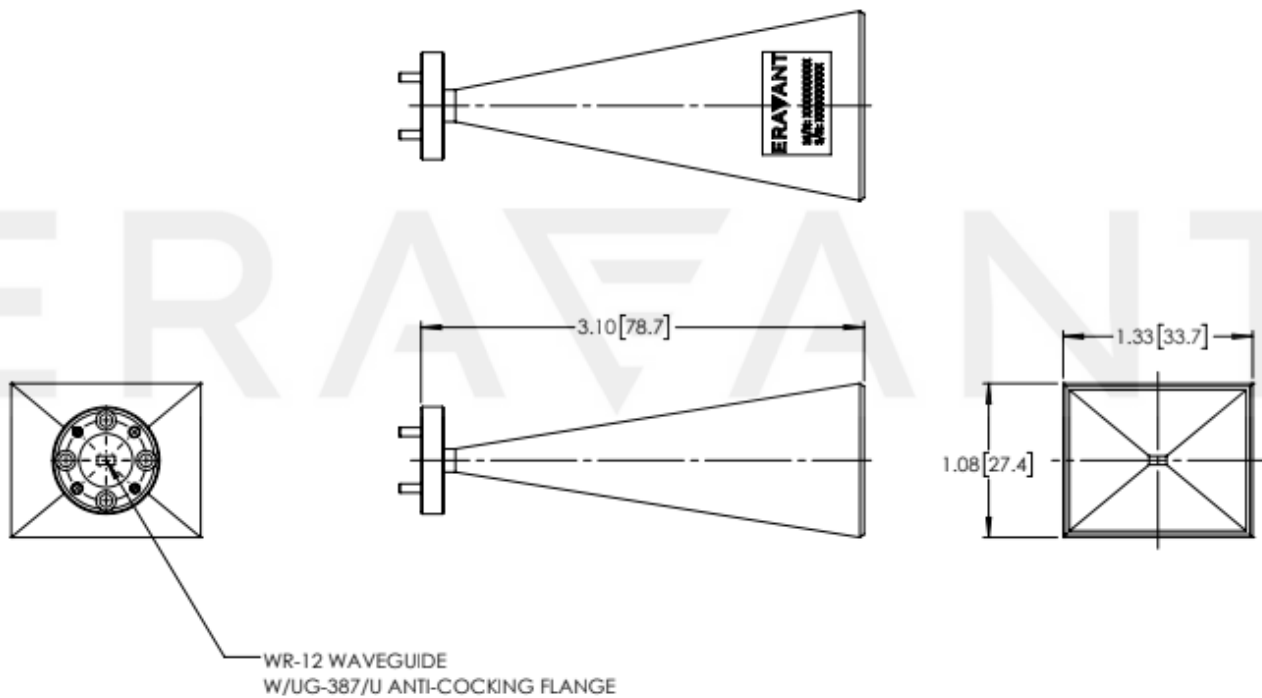

NOTE:

- This antenna is a mature product. The reasons for only providing simulated data can be found in the following blog [here](#).
- Eravant reserves the right to change the information presented without notice.

CAUTION:

- If a waveguide is present, any foreign objects in the waveguide will cause performance degradation and may damage or destroy the unit.
- Any foreign objects in the antenna will cause performance degradation and possible device damage.

ERAVANT
MAKING MILLIMETERWAVE ACCESSIBLE

ERAVANT
MAKING MILLIMETERWAVE ACCESSIBLE