



WR-42 Pyramidal Horn Antenna, 20 dBi Gain

Description:

Model SAR-2013-42-S2 is a K-band pyramidal horn antenna that operates from 18 GHz to 26.5 GHz. The antenna offers 20 dBi nominal gain and a typical half power beamwidth of 15 degrees on the E-plane and 16 degrees on the H-plane, respectively. The antenna supports linear polarized waveforms. The input port of the antenna is a WR-42 waveguide with UG-595/U flange.



Features:

- Rectangular Waveguide Interface
- Precisely Machined
- Linear Polarization
- High Return Loss

Applications:

- Antenna Ranges
- Antenna Gain Measurements
- System Setups

Electrical Specifications:

Parameter	Minimum	Typical	Maximum
Frequency	18 GHz		26.5 GHz
Gain	18.5 dBi	20 dBi	21 dBi
Polarization	Linear		
3 dB Beamwidth, E-Plane		15°	
3 dB Beamwidth, H-Plane		16°	
Sidelobes, E-Plane		-14 dB	
Sidelobes, H-Plane		-30 dB	
Return Loss		23 dB	
Specification Temperature		+25 °C	
Operating Temperature	-40 °C		+85 °C

Mechanical Specifications:

Item	Specification
Antenna Port	WR-42 Waveguide
Flange Type	UG-595/U Flange
Material	Aluminum
Finish	Inside: Silver Plated; Outside: Black Paint
Weight	2.5 Oz
Size	3.20" (L) X 2.47" (W) X 1.93" (H)
Outline	AR-K1





WR-42 Pyramidal Horn Antenna, 20 dBi Gain

Simulated Antenna Patterns @ 18 GHz

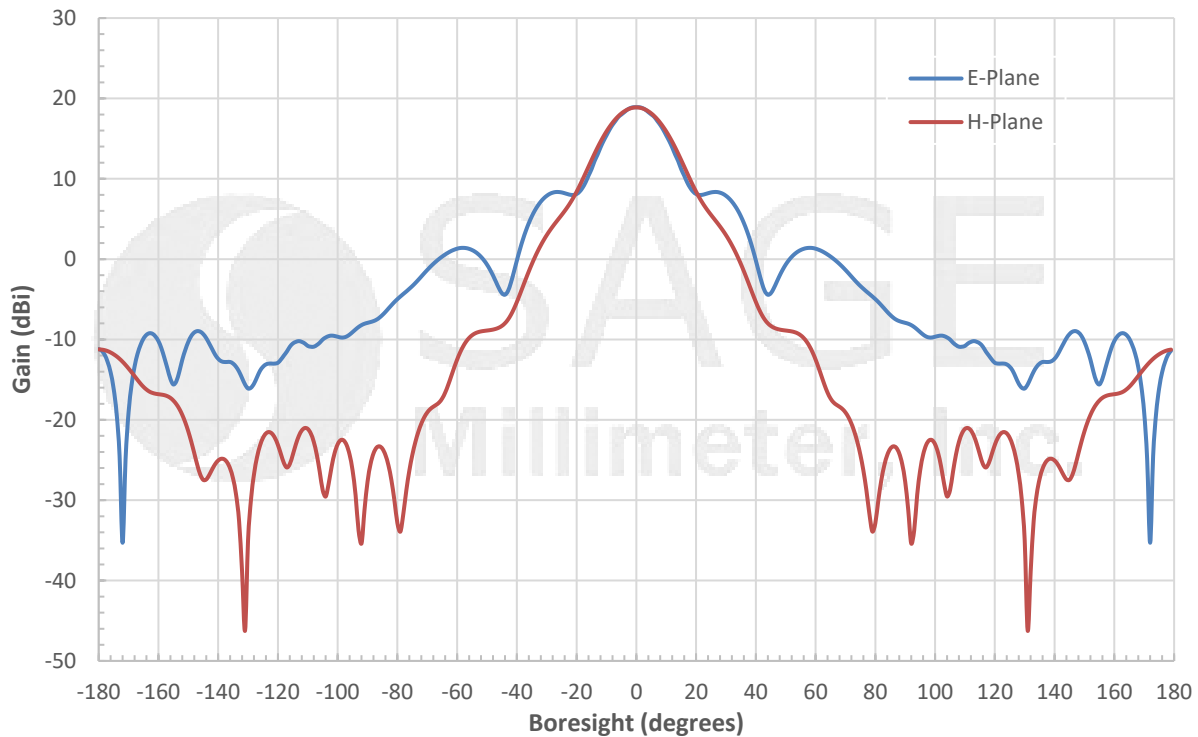

Simulated Antenna Patterns @ 22 GHz

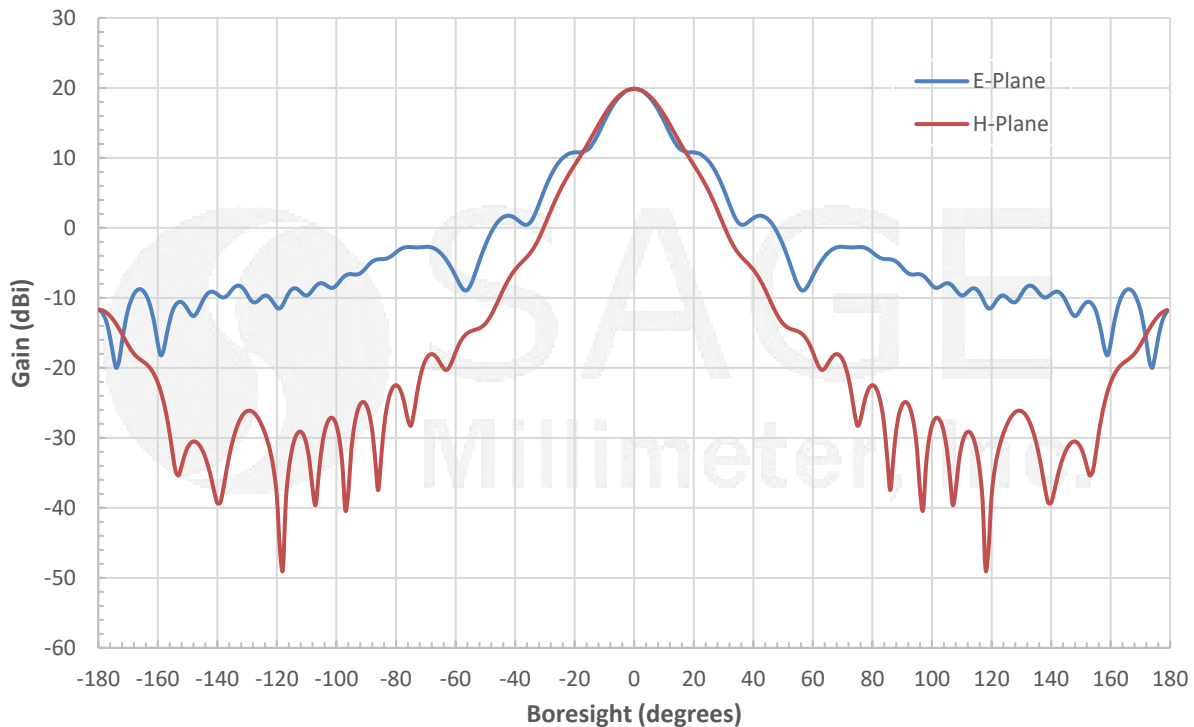



WR-42 Pyramidal Horn Antenna, 20 dBi Gain

Simulated Antenna Patterns @ 26.5 GHz

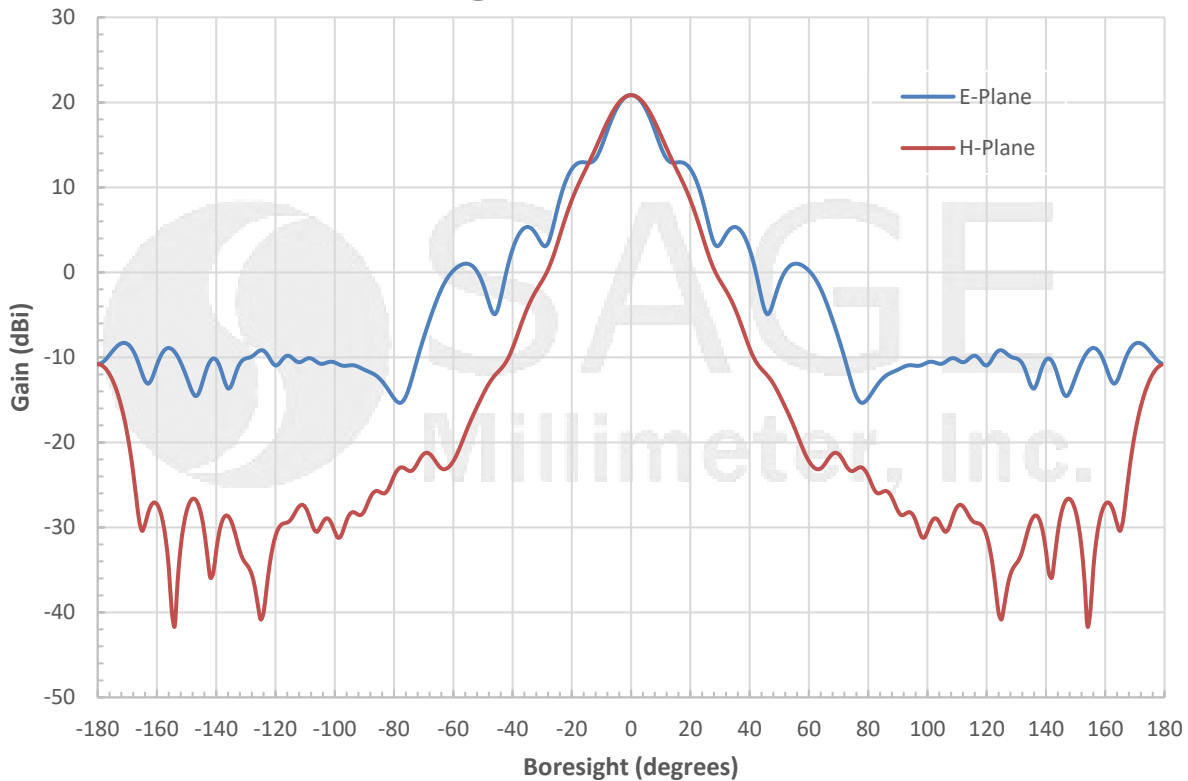

Simulated Return Loss vs. Frequency

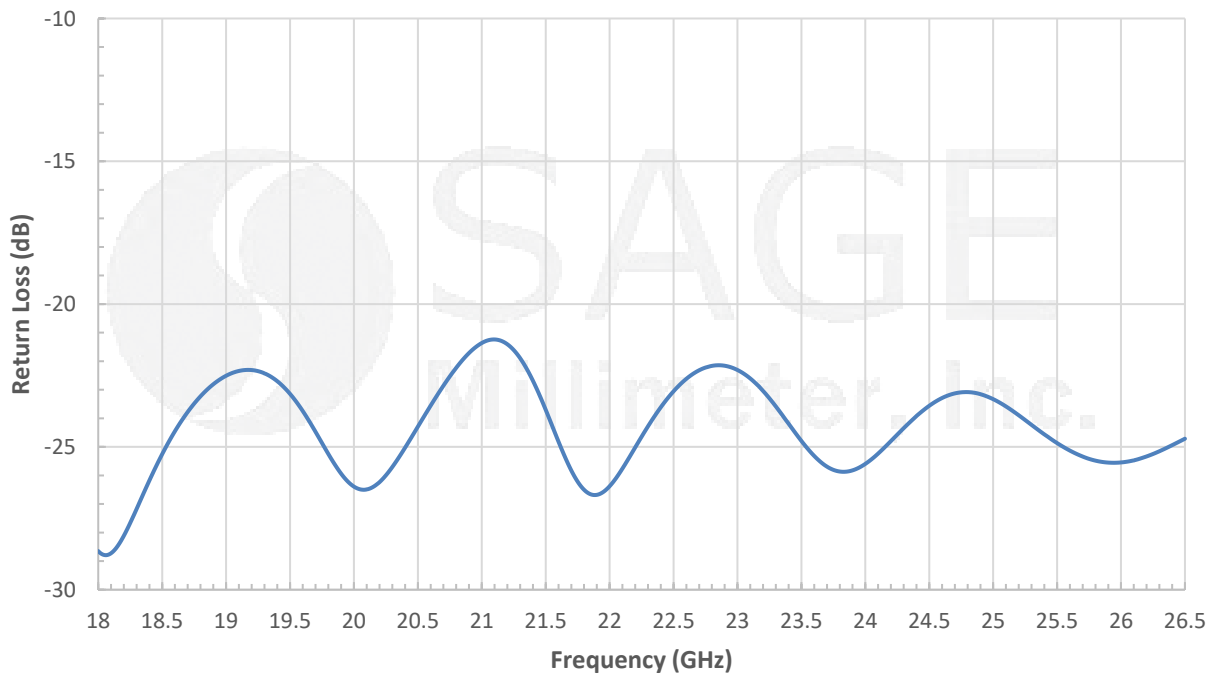



WR-42 Pyramidal Horn Antenna, 20 dBi Gain

Simulated Gain vs. Frequency

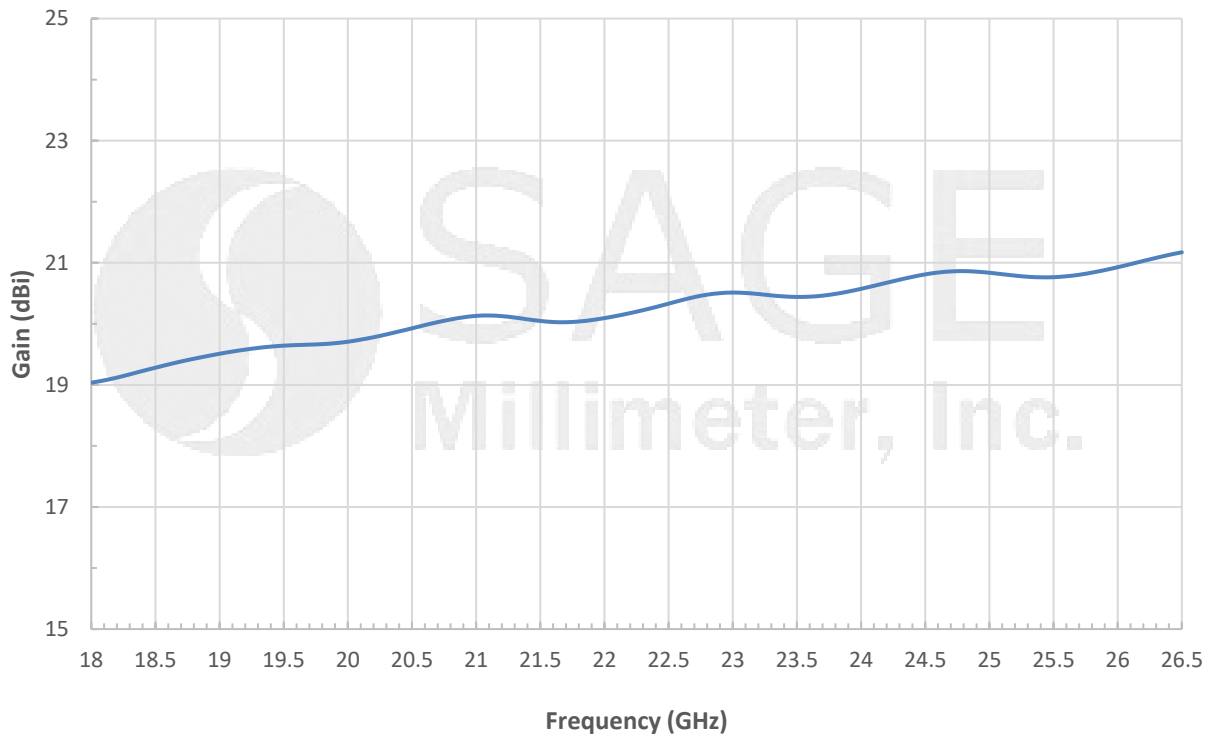

Mechanical Outline: (Unless otherwise specified, all dimensions are in inches [millimeters])

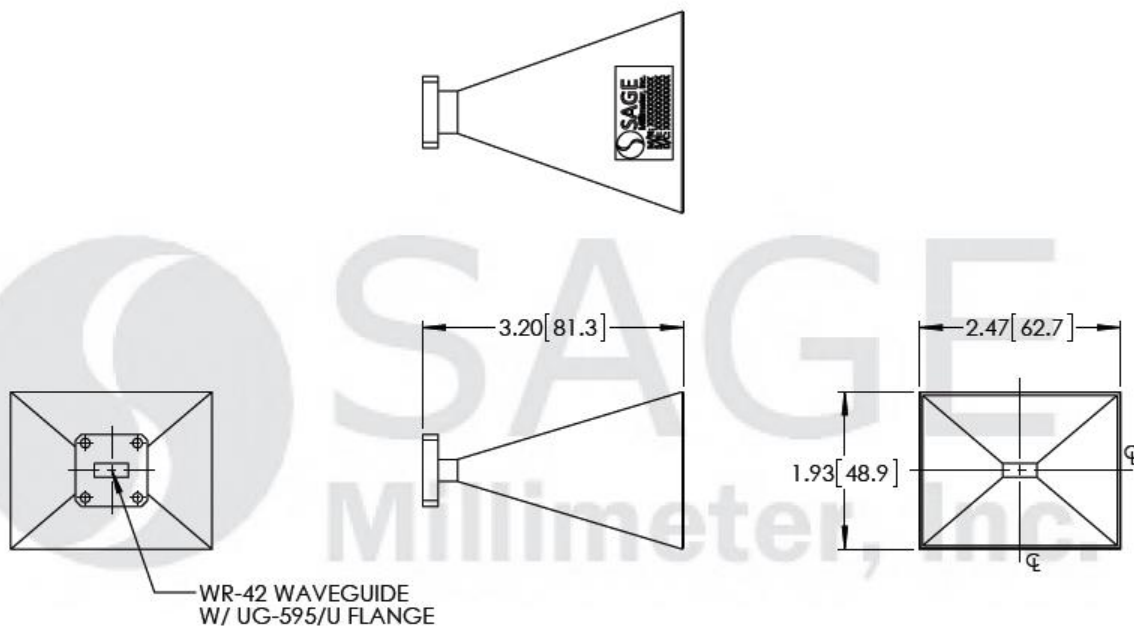



WR-42 Pyramidal Horn Antenna, 20 dBi Gain

Note:

- This antenna is a mature product. The reasons for only providing simulated data can be found in the following blog [here](#).
- Eravant reserves the right to change the information presented without notice.

Caution:

- Any foreign objects in the waveguide will cause performance degradation and possible device damage.

