

## SAR-2013-15-S2

### WR-15 Pyramidal Horn Antenna, 20 dBi Gain

**SAR-2013-15-S2** is a V-band pyramidal horn antenna that operates from 50 GHz to 75 GHz. The antenna offers 20 dBi nominal gain and a typical half power beamwidth of 14 degrees on the E-plane and 15 degrees on the H-plane. The antenna supports linear polarized waveforms. The input of this antenna is a WR-15 waveguide with UG-385/U anti-cocking flange.



#### Electrical Specifications:

Parameter	Minimum	Typical	Maximum
Frequency	50 GHz		75 GHz
Gain		20 dBi	
Polarization		Linear	
3 dB Beamwidth, E-Plane		14°	
3 dB Beamwidth, H-Plane		15°	
Sidelobes, E-Plane		-14 dB	
Sidelobes, H-Plane		-30 dB	
Return Loss		23 dB	
Specification Temperature		+25 °C	
Operation Temperature	-40 °C		+85 °C

#### Mechanical Specifications:

Item	Specification
Antenna Port	WR-15 Waveguide
Flange Type	UG-385/U Anti-Cocking Flange
Size	1.20" (L) X 0.93" (W) X 0.75" (H)
Material	Brass
Finish	Gold Plated
Weight	0.80 Oz
Outline	AR-V1-A

#### ECCN

EAR99

#### FEATURES

- Rectangular Waveguide Interface
- Precisely Machined and Gold Plated
- Linear Polarization
- High Return Loss

#### APPLICATIONS

- Antenna Ranges
- Antenna Gain Measurements
- System Setups

#### SUPPLEMENTAL DETAILS



Simulated Antenna Patterns @ 50 GHz

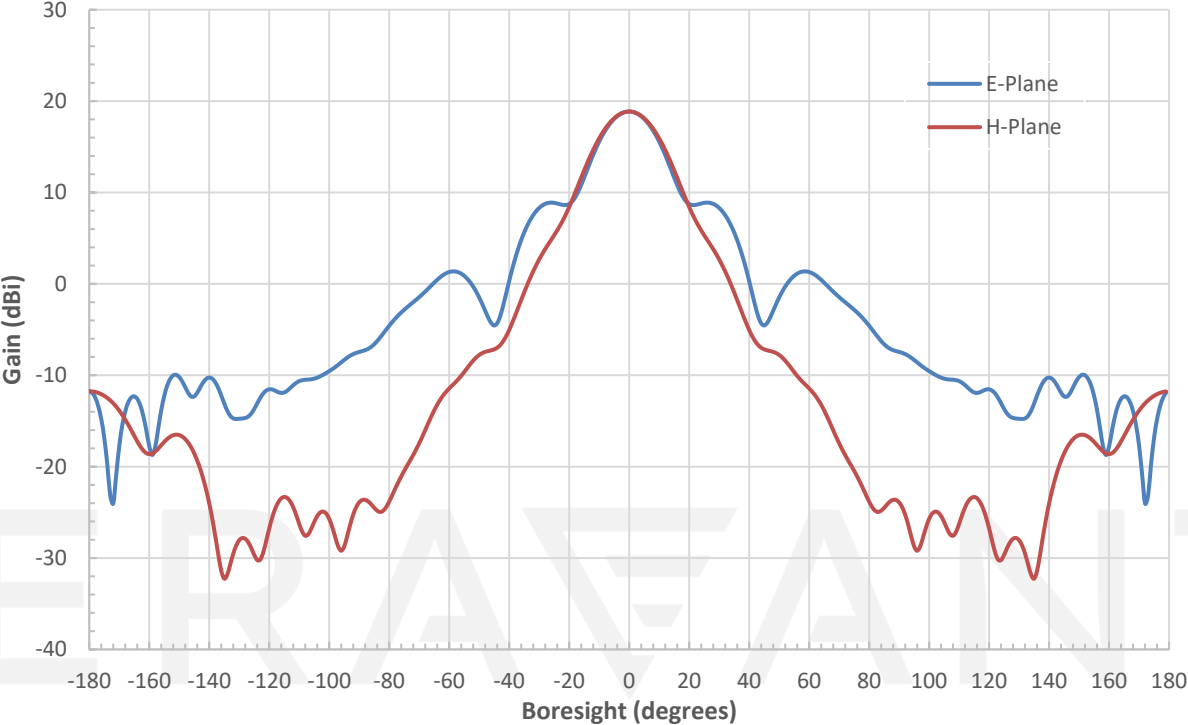

Simulated Antenna Patterns @ 62.5 GHz

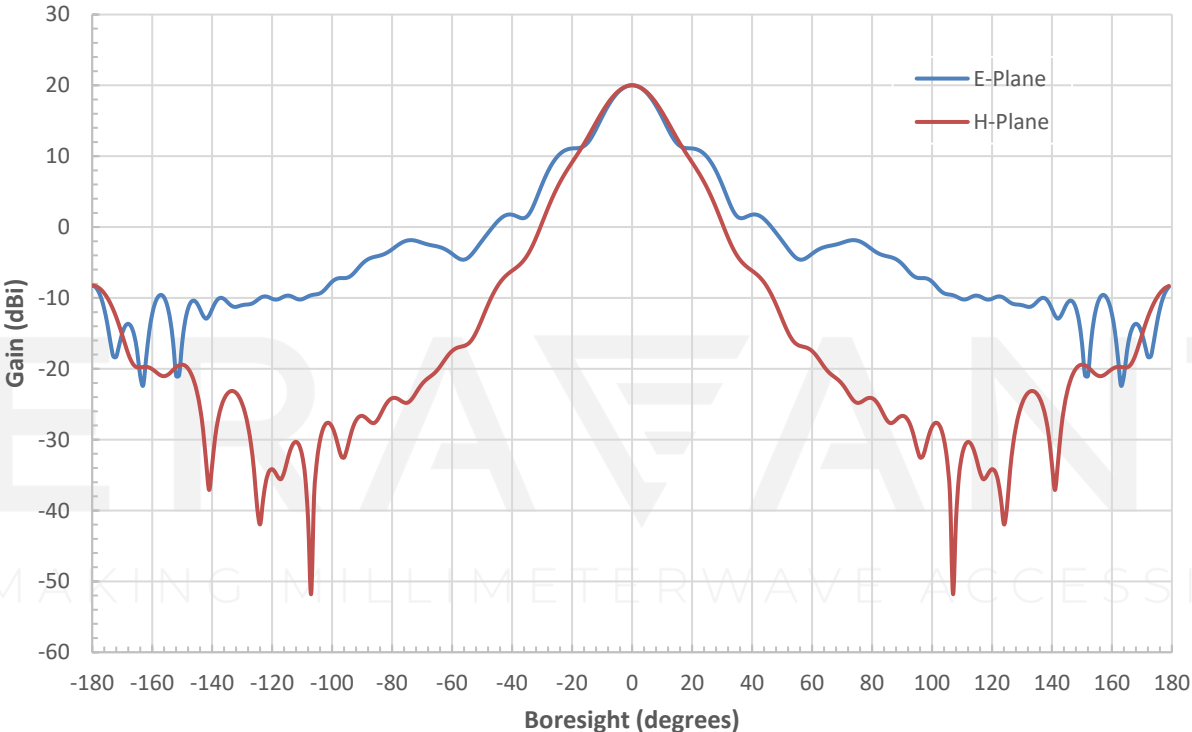

Simulated Antenna Patterns @ 75 GHz

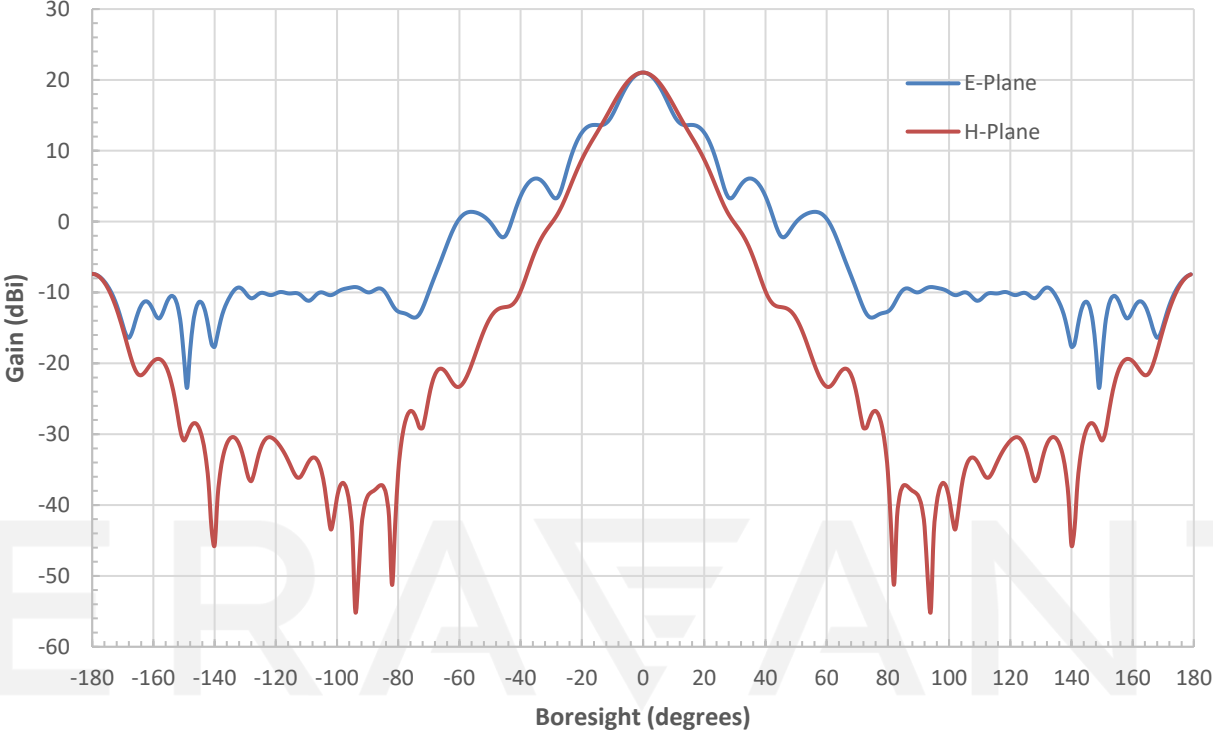

Measured Return Loss vs. Frequency

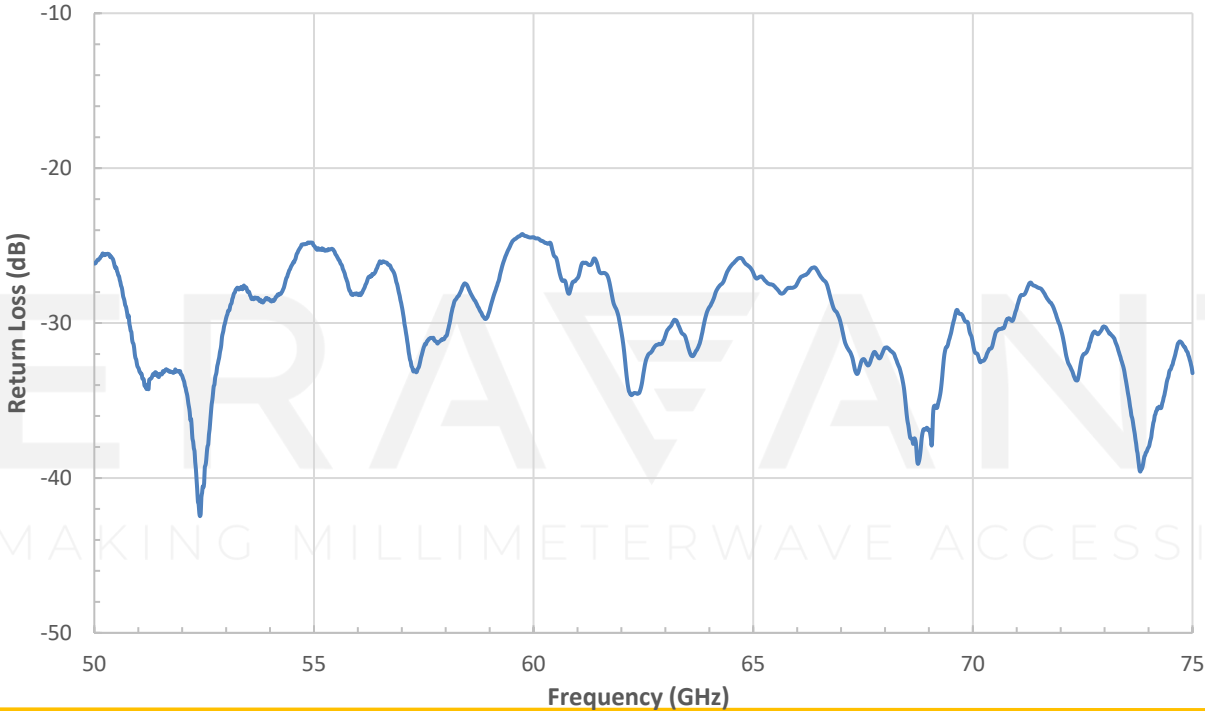

Simulated Gain vs. Frequency

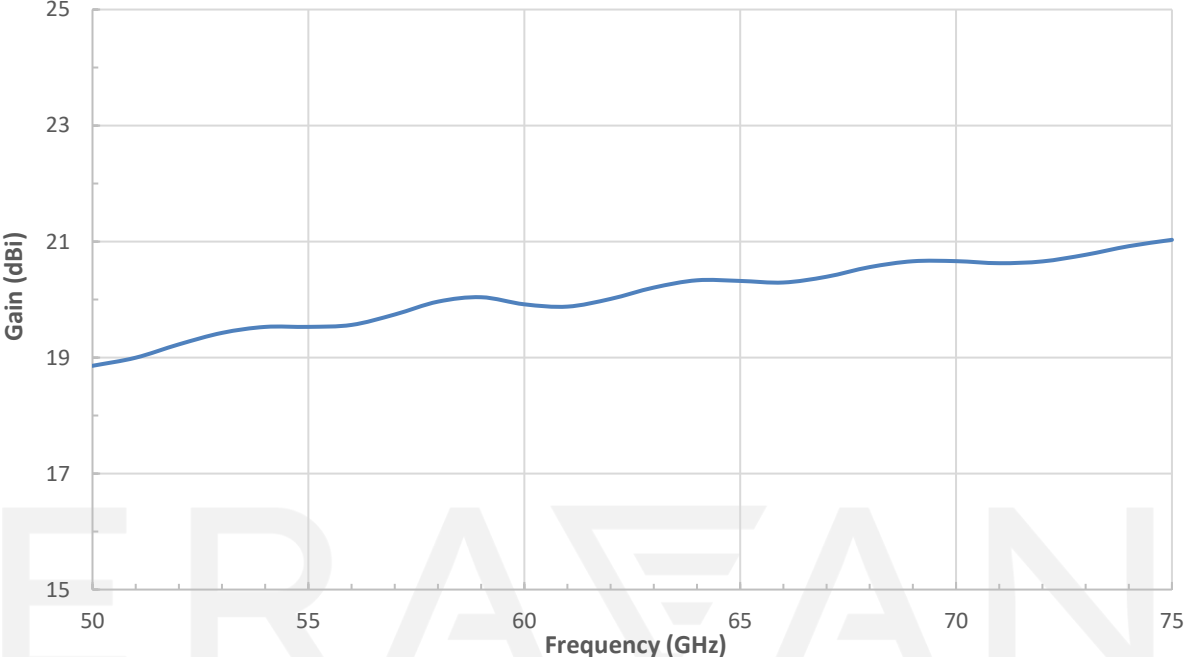

**Mechanical Outline:**

Unless otherwise specified, all dimensions are in inches [millimeters]

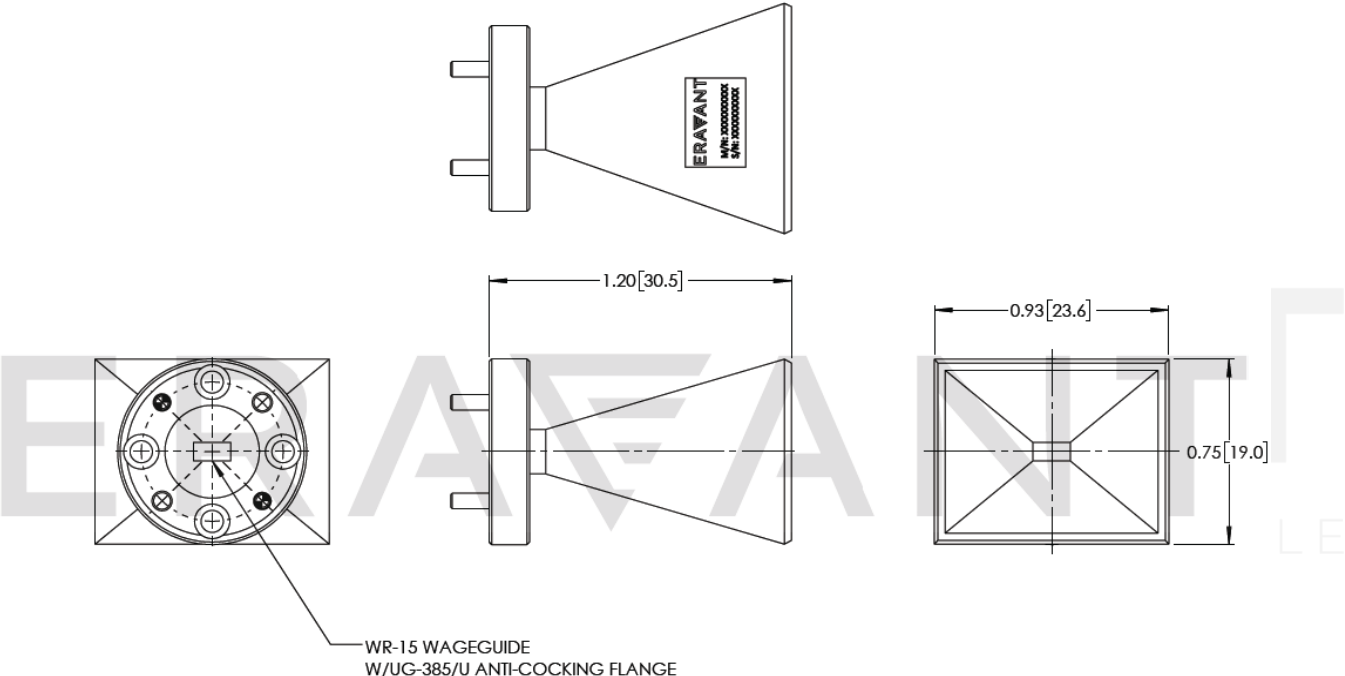

---

**NOTE:**

- This antenna is a mature product. The reasons for only providing simulated data can be found in the following blog [here](#).
- Eravant reserves the right to change the information presented without notice.

**CAUTION:**

- Any foreign objects in the waveguide will cause performance degradation and possible device damage.

ERAVANT  
MAKING MILLIMETERWAVE ACCESSIBLE

ERAVANT  
MAKING MILLIMETERWAVE ACCESSIBLE