

## SAR-2013-10-S2

### WR-10 Pyramidal Horn Antenna, 20 dBi Gain

**SAR-2013-10-S2** is a W-band pyramidal horn antenna that operates from 75 GHz to 110 GHz. The antenna offers 20 dBi nominal gain and a typical half power beamwidth of 16 degrees on the E-plane and 18 degrees on the H-plane. The antenna supports linear polarized waveforms. The input of this antenna is a WR-10 waveguide with UG-387/U-M anti-cocking flange.



#### Electrical Specifications:

Parameter	Minimum	Typical	Maximum
Frequency	75 GHz		110 GHz
Gain		20 dBi	
Polarization		Linear	
3 dB Beamwidth, E-Plane		16°	
3 dB Beamwidth, H-Plane		18°	
Sidelobes, E-Plane		-14 dB	
Sidelobes, H-Plane		-30 dB	
Return Loss		23	
Specification Temperature		+25°C	
Operating Temperature	-40°C		+85°C

#### Mechanical Specifications:

Item	Specification
Antenna Port	WR-10 Waveguide with UG-387/U-M Anti-Cocking Flange
Material	Brass
Finish	Gold Plated
Weight	3.5 Oz
Outline	TA-MD-A-1.2

#### ECCN

EAR99

#### FEATURES

- Full Band Coverage
- Compact Size
- High Resolution Micrometer
- Low Insertion Loss

#### APPLICATIONS

- Test Lab
- Instrumentations
- System Integration

#### SUPPLEMENTAL DETAILS



Simulated Antenna Patterns @ 75 GHz

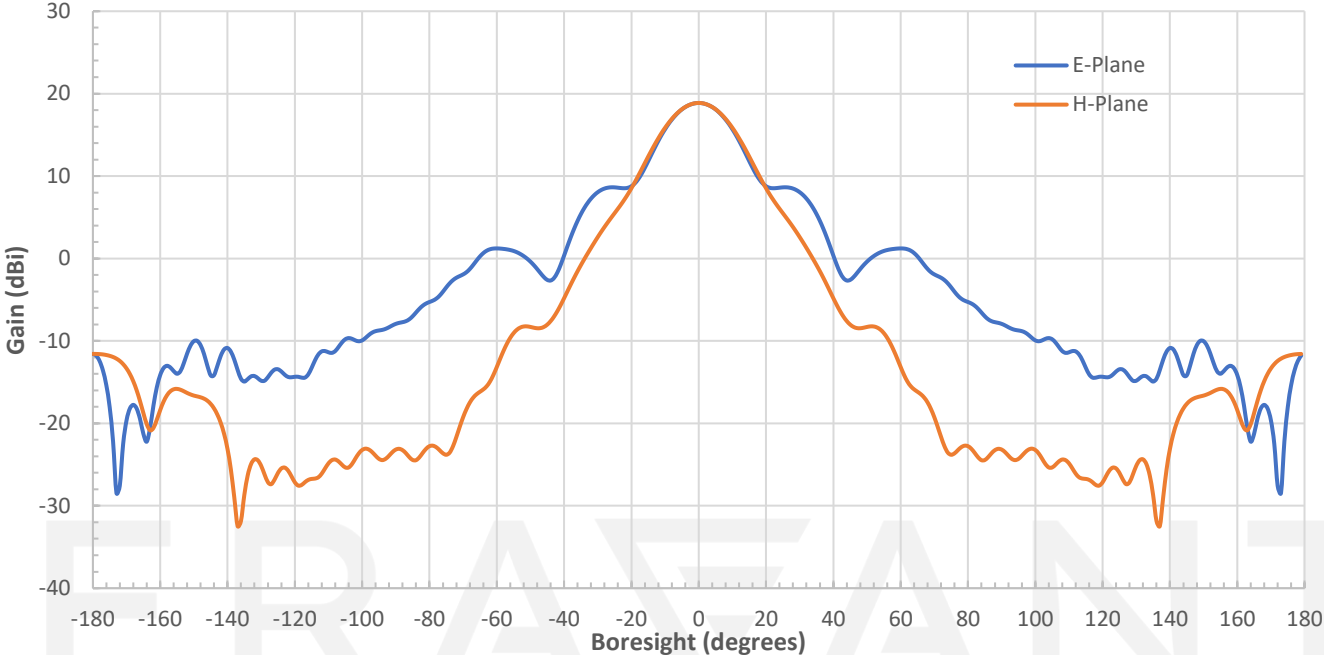

Simulated Antenna Patterns @ 92.5 GHz

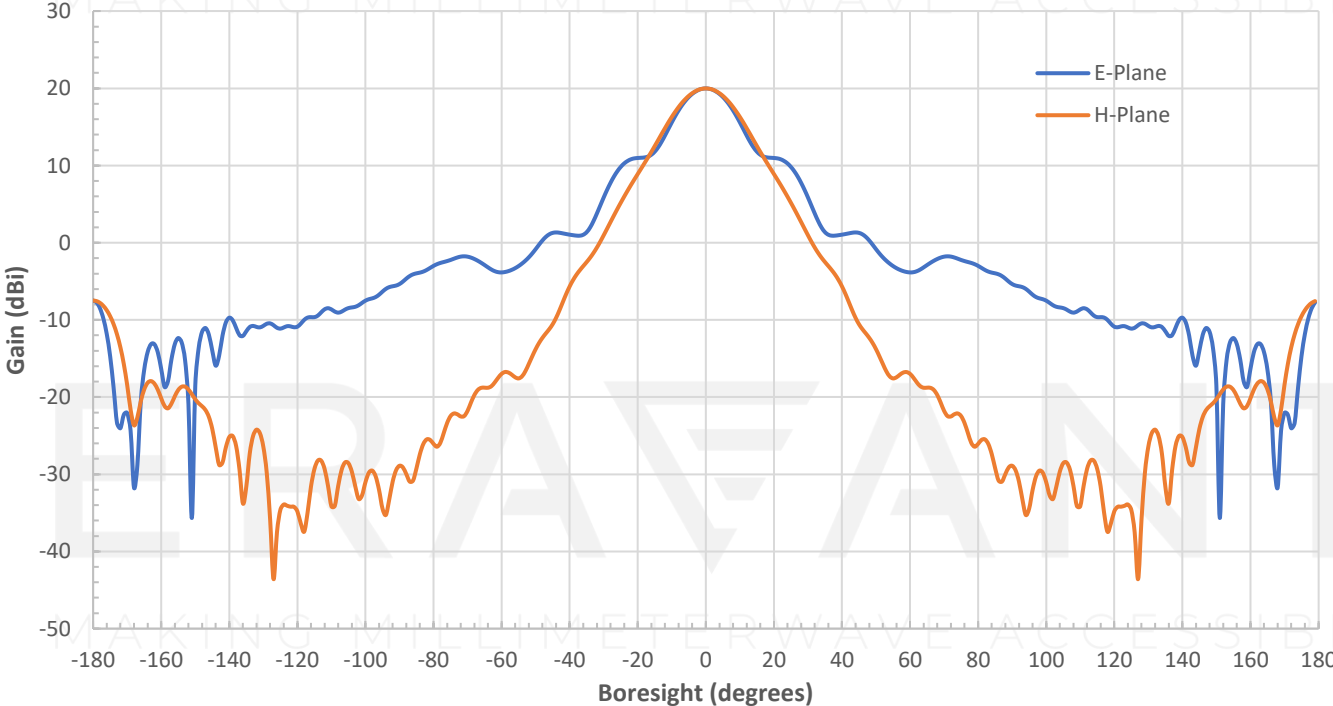

### Simulated Antenna Patterns @ 110 GHz

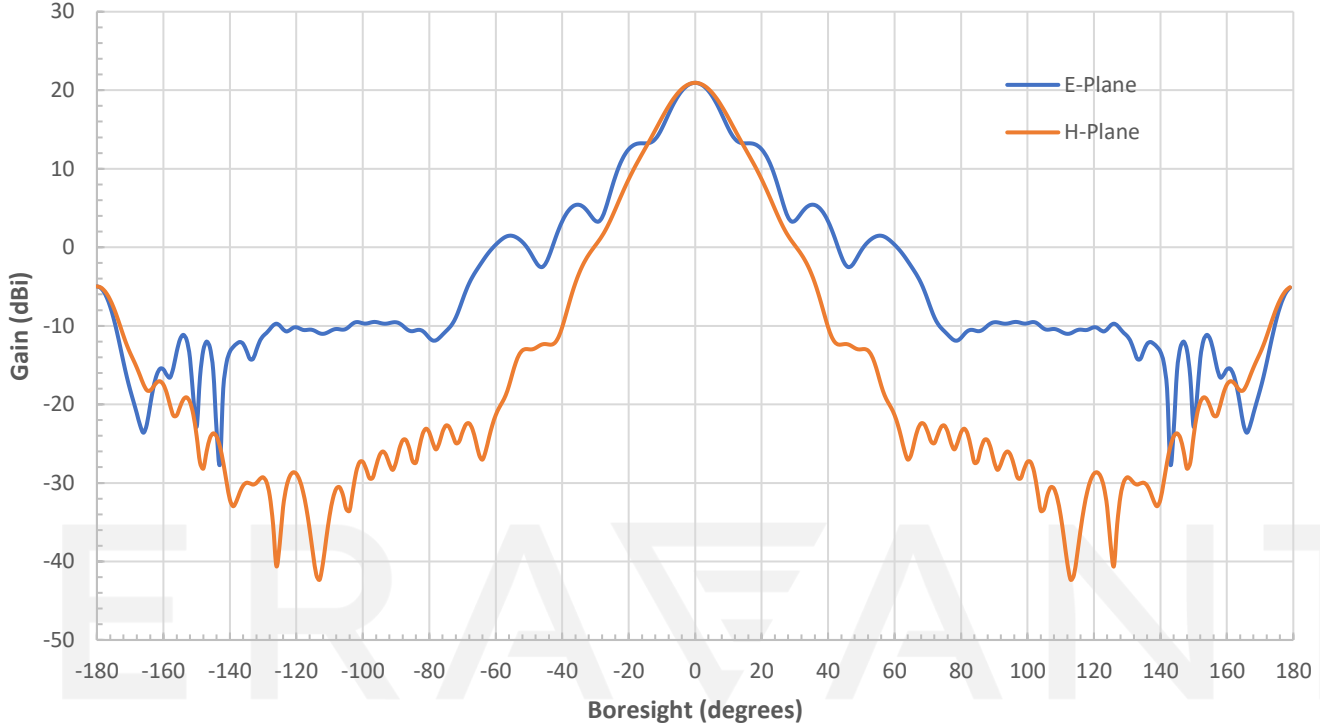

MAKING MILLIMETERWAVE ACCESSIBLE

### Simulated Gain vs. Frequency

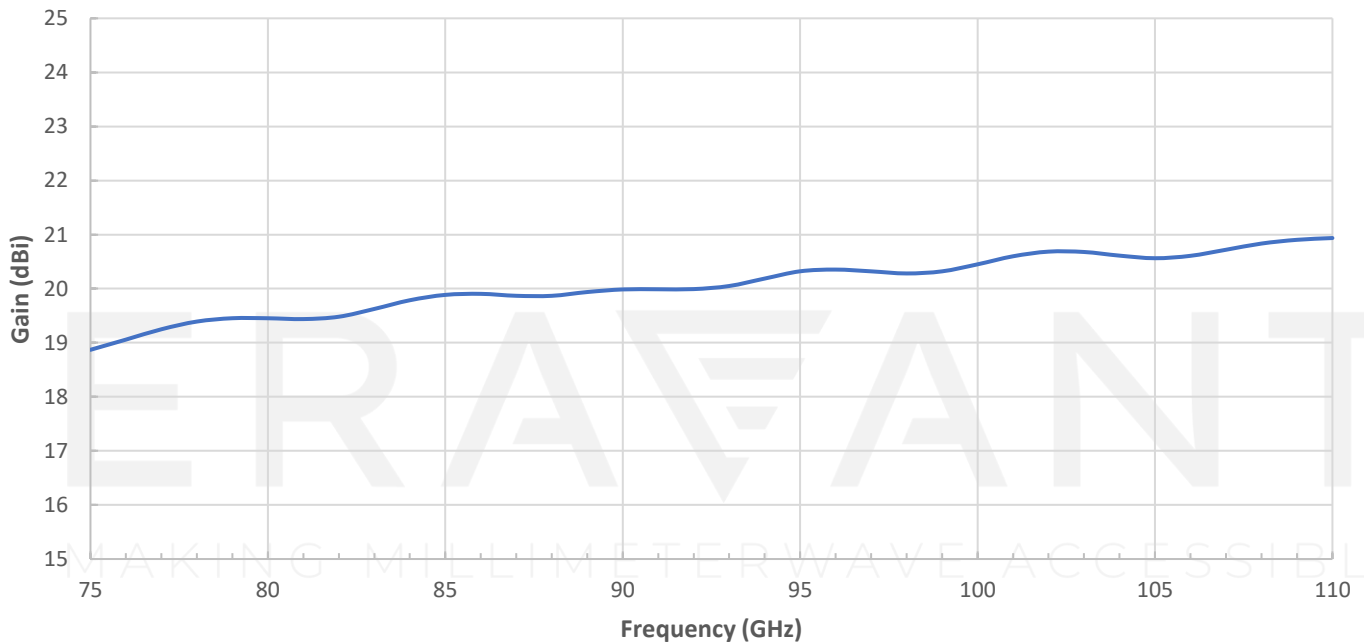

MAKING MILLIMETERWAVE ACCESSIBLE

### Simulated Return Loss vs. Frequency

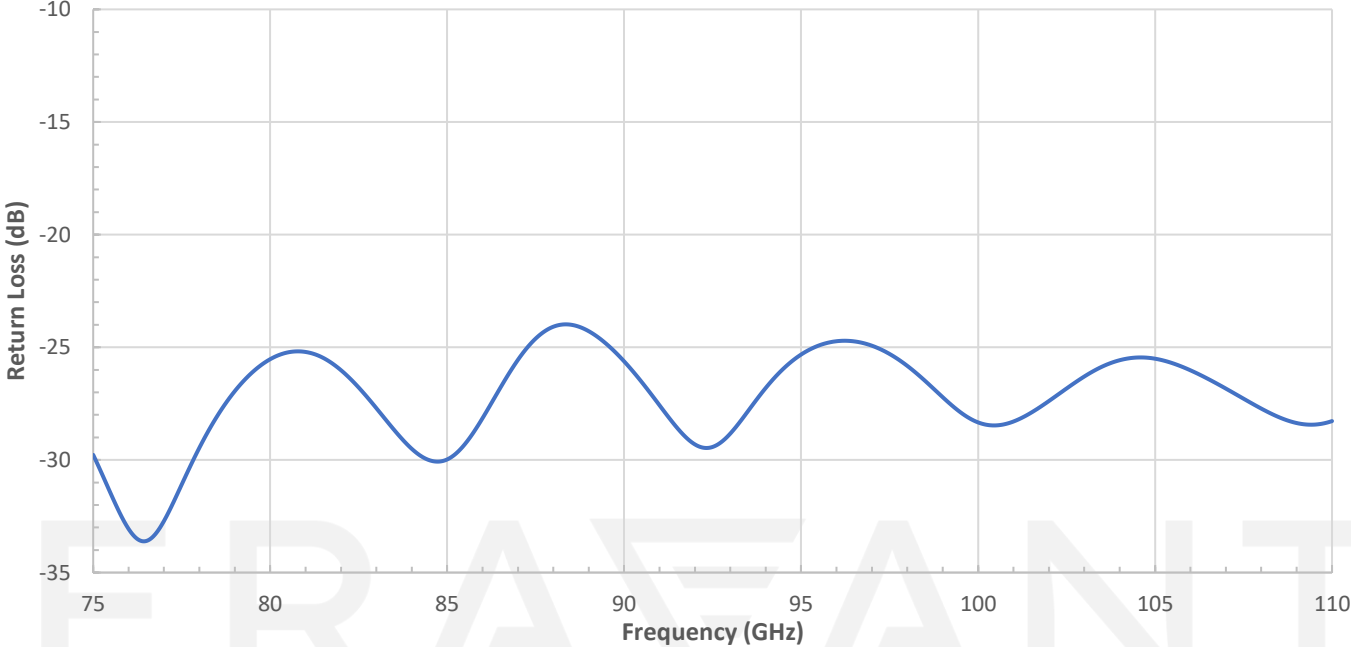

**Mechanical Outline:** (Unless otherwise specified, all dimensions are in inches [millimeters])

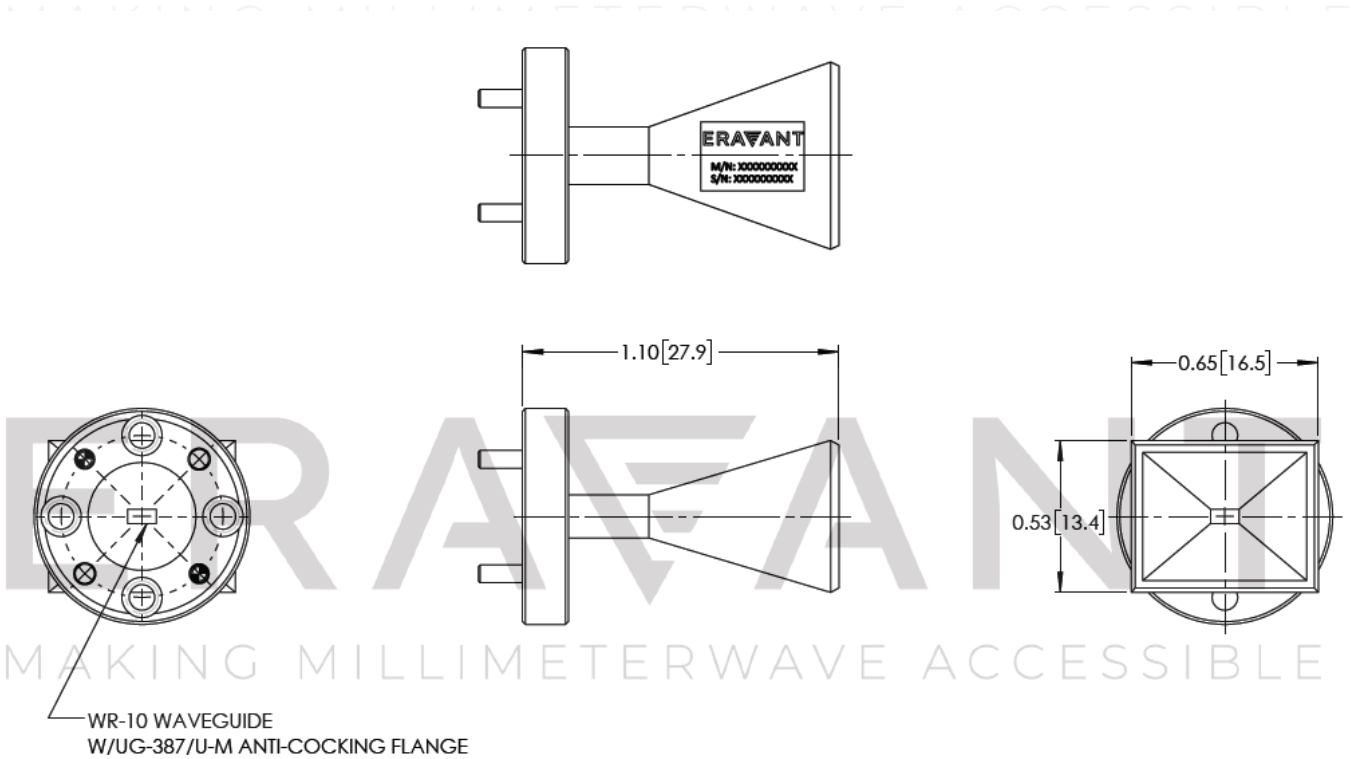

**NOTE:**

- This antenna is a mature product. The reason for only providing simulated data can be found in the following blog [here](#).
- Eravant reserves the right to change the information presented without notice.

**CAUTION:**

- Any foreign objects in the antenna will cause performance degradation and possible device damage.

ERAVANT  
MAKING MILLIMETERWAVE ACCESSIBLE

ERAVANT  
MAKING MILLIMETERWAVE ACCESSIBLE