

SAR-1725-34-S2

WR-34 Pyramidal Horn Antenna, 17 dBi Gain

SAR-1725-34-S2 is a pyramidal horn antenna that operates from 22 GHz to 33 GHz. The antenna offers 17 dBi typical gain and a typical half power beamwidth of 26 degrees on the E-plane and 24 degrees on the H-plane. The antenna supports linear polarized waveforms. The input of this antenna is a WR-34 waveguide with UG-1530/U flange.



Electrical Specifications:

| Parameter | Minimum | Typical | Maximum |
|---------------------------|---------|---------|---------|
| Frequency Range | 22 GHz | | 33 GHz |
| Gain | | 17 dBi | |
| Polarization | | Linear | |
| 3 dB Beamwidth, E-Plane | | 26° | |
| 3 dB Beamwidth, H-Plane | | 24° | |
| Sidelobes, E-Plane | | -14 dB | |
| Sidelobes, H-Plane | | -36 dB | |
| Return Loss | | 23 dB | |
| Specification Temperature | | +25°C | |
| Operating Temperature | -40°C | | +85°C |

Mechanical Specifications:

| Item | Specification |
|--------------|-----------------------------------|
| Antenna Port | WR-34 Waveguide |
| Flange Type | UG-1530/U Flange |
| Material | Aluminum |
| Finish | Gold Plated |
| Weight | 0.5 Oz |
| Size | 2.10" (L) X 1.30" (W) X 0.95" (H) |
| Outline | AR-317 |

ECCN

EAR99

FEATURES

- Rectangular Waveguide Interface
- Precisely Machined and Gold Plated
- Linear Polarization
- High Return Loss

APPLICATIONS

- Antenna Ranges
- Antenna Gain Measurements
- System Setups

SUPPLEMENTAL DETAILS



SAR-1725-34-S2

Simulated Antenna Patterns @ 22 GHz

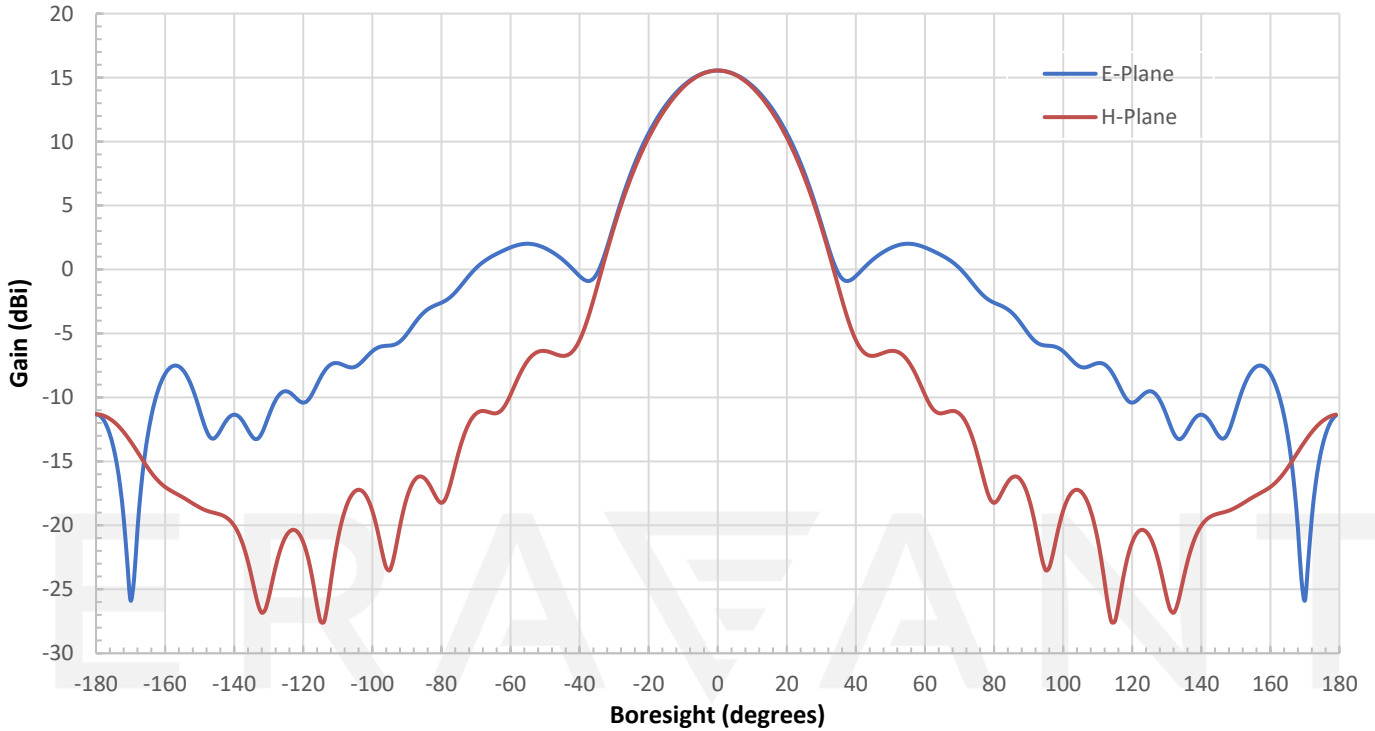

Simulated Antenna Patterns @ 27.5 GHz

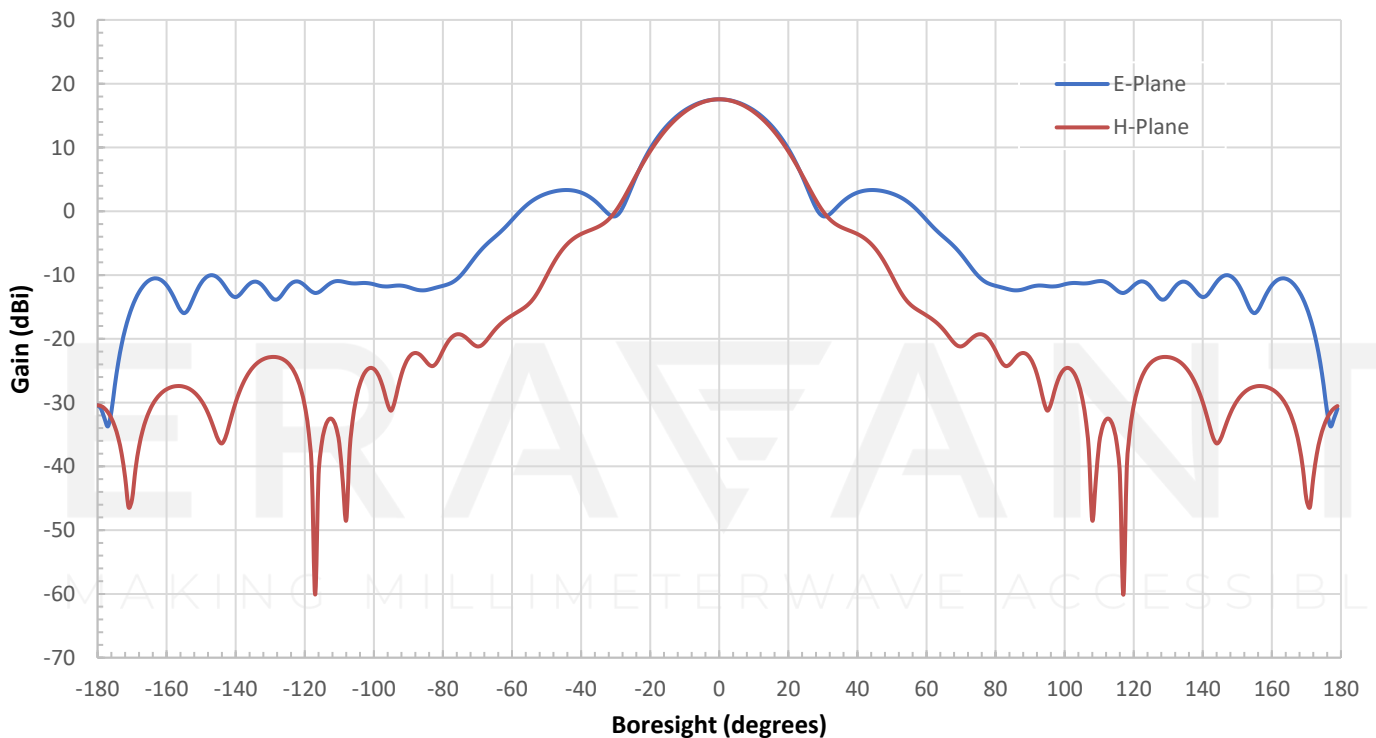

Simulated Antenna Patterns @ 33 GHz

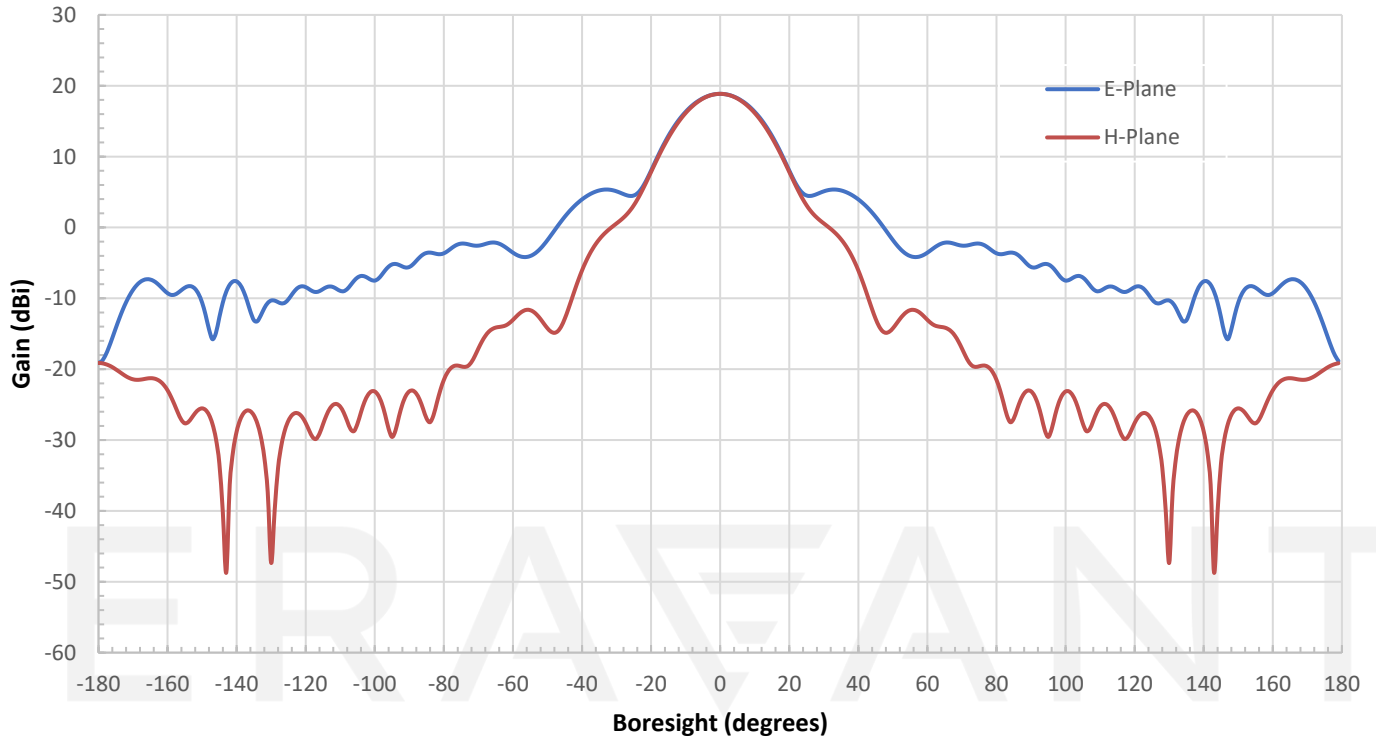

Simulated Return Loss vs. Frequency

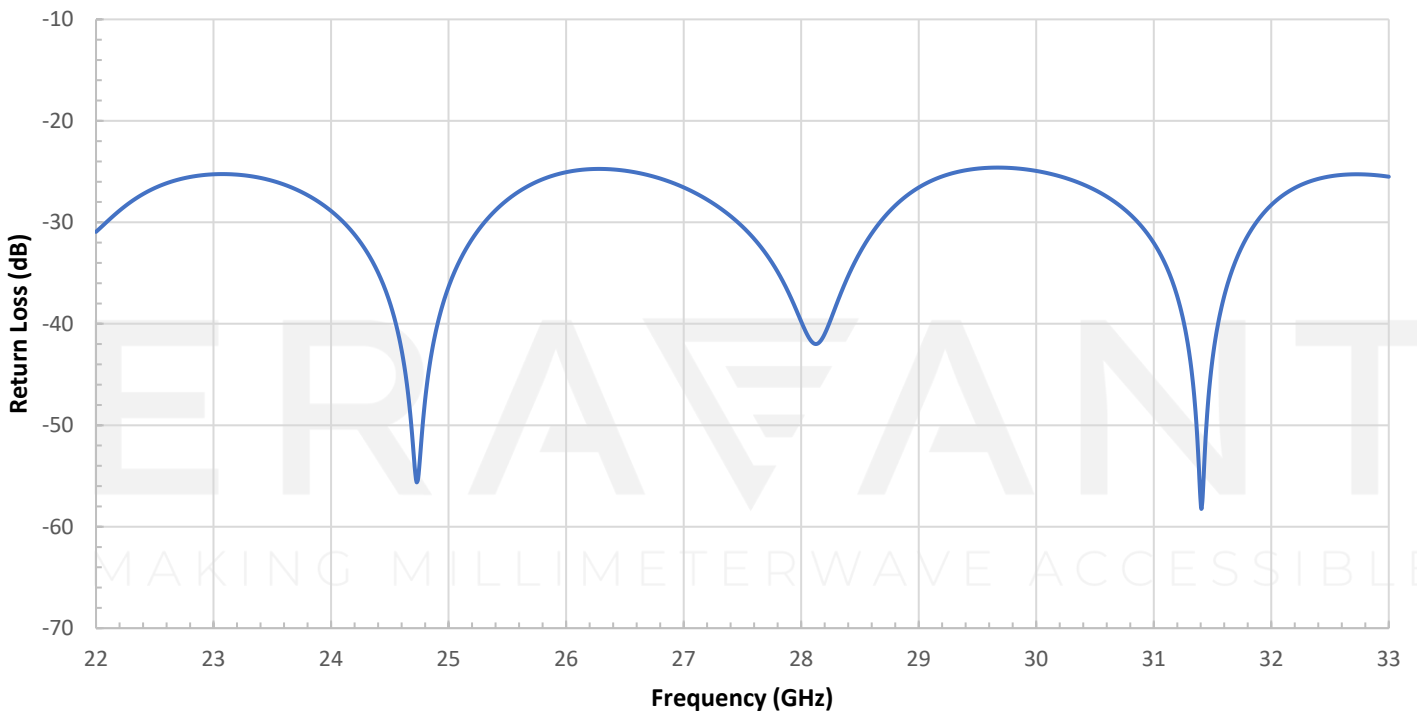

SAR-1725-34-S2

Simulated Gain vs. Frequency

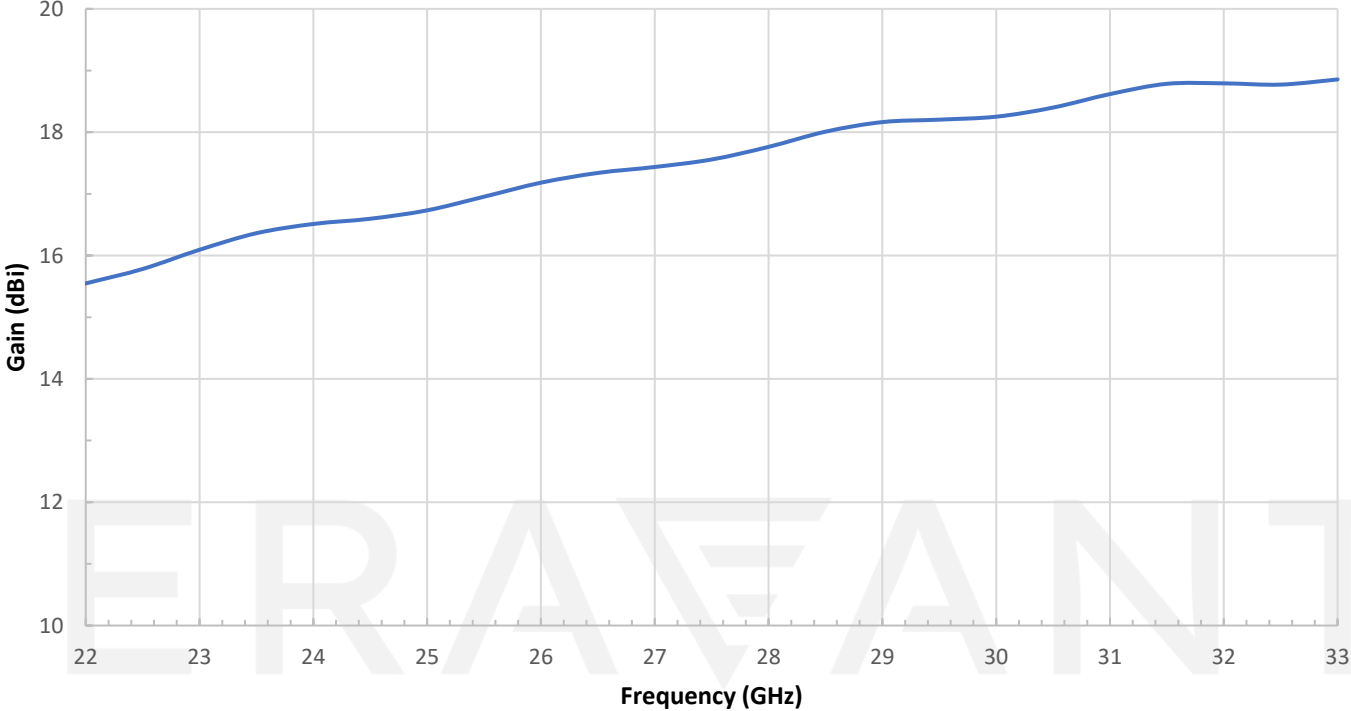

Mechanical Outline: Unless otherwise specified, all dimensions are in inches [millimeters]

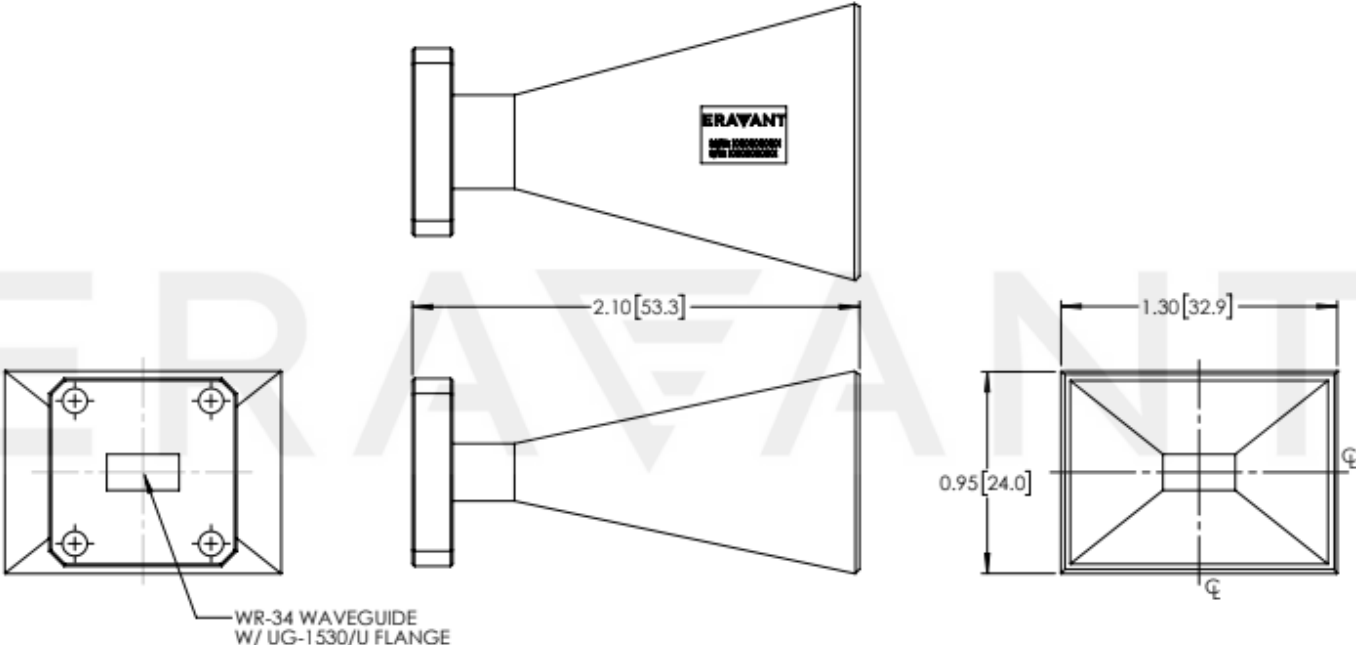

NOTE:

- This antenna is a mature product. The reasons for only providing simulated data can be found in the following blog [here](#).
- Eravant reserves the right to change the information presented without notice.

CAUTION:

- If a waveguide is present, any foreign objects in the waveguide will cause performance degradation and may damage or destroy the unit.
- Any foreign objects in the antenna will cause performance degradation and possible device damage.

ERAVANT
MAKING MILLIMETERWAVE ACCESSIBLE

ERAVANT
MAKING MILLIMETERWAVE ACCESSIBLE