



WR-15 Pyramidal Horn Antenna, 17 dBi Gain with 1.85 mm (V) Coax Input

Description:

Models SAR-1725-15VF-E2 and SAR-1725-15VM-E2 are V-band pyramidal horn antennas equipped with end launch (180°) 1.85 mm coax connectors to cover the frequency range of 50 GHz to 70 GHz. The antennas offer 17 dBi nominal gain and a typical half power beamwidth of 26 degrees on the E-plane and 25 degrees on the H-plane. The antennas only support linear polarized waveforms. Right angle (90°) 1.85 mm coax connector configurations are available under the models **SAR-1725-15VF-R2 and SAR-1725-15VM-R2**.



Features:

- Inline Configuration
- Linear Polarization
- DC Short Circuit at Input

Applications:

- Antenna Ranges
- Antenna Gain Measurements
- System Setups

Electrical Specifications:

Parameter	Minimum	Typical	Maximum
Frequency	50 GHz		70 GHz
Gain		17 dBi	
Polarization		Linear	
3 dB Beamwidth, E-Plane		26°	
3 dB Beamwidth, H-Plane		25°	
Sidelobes, E-Plane		-13 dB	
Sidelobes, H-Plane		-20 dB	
Return Loss		15 dB	
Power Handling			30 W (CW)
Specification Temperature		+25 °C	
Operating Temperature	-40 °C		+85 °C

Mechanical Specifications:

Item	Specification
Antenna Port	1.85 mm Female for Model Number: SAR-1725-15VF-E2
	1.85 mm Male for Model Number: SAR-1725-15VM-E2
Material	Brass
Finish	Gold Plated
Weight	0.9 Oz
Size	1.45" (L) X 0.59" (W) X 0.47" (H)
Outline	AR-VC17-E





WR-15 Pyramidal Horn Antenna, 17 dBi Gain with 1.85 mm (V) Coax Input

Simulated Antenna Patterns @ 50 GHz

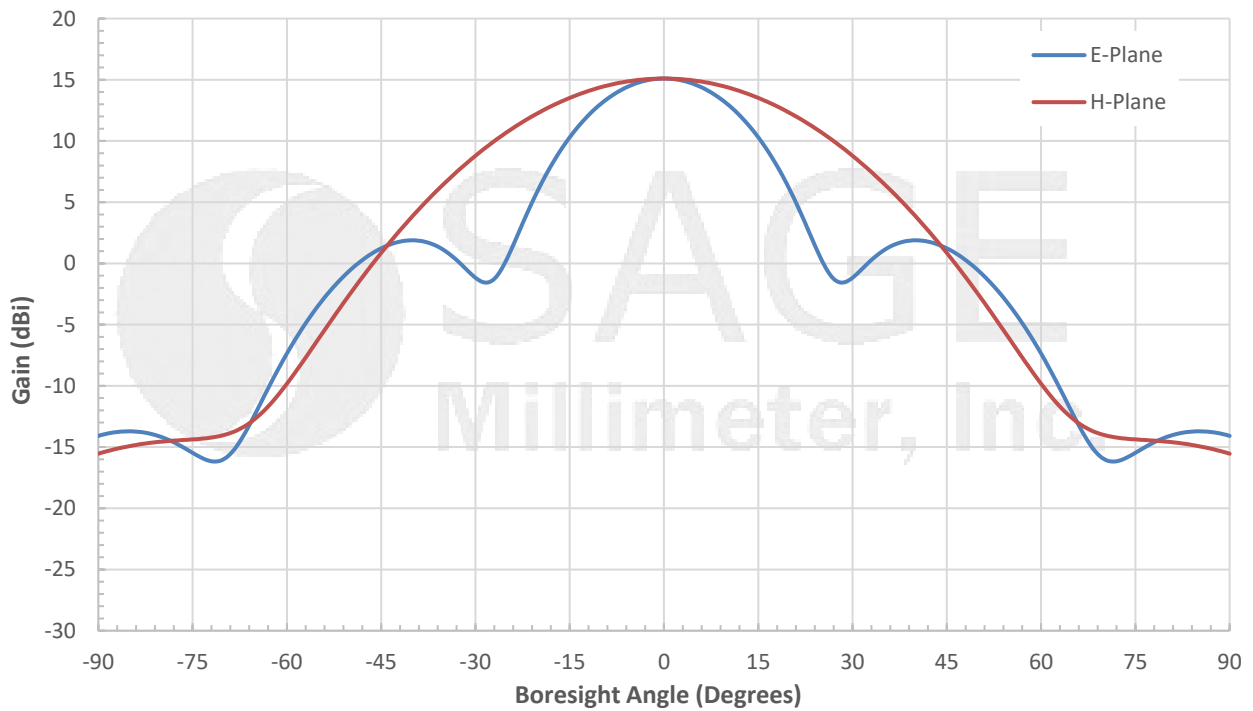

Simulated Antenna Patterns @ 60 GHz

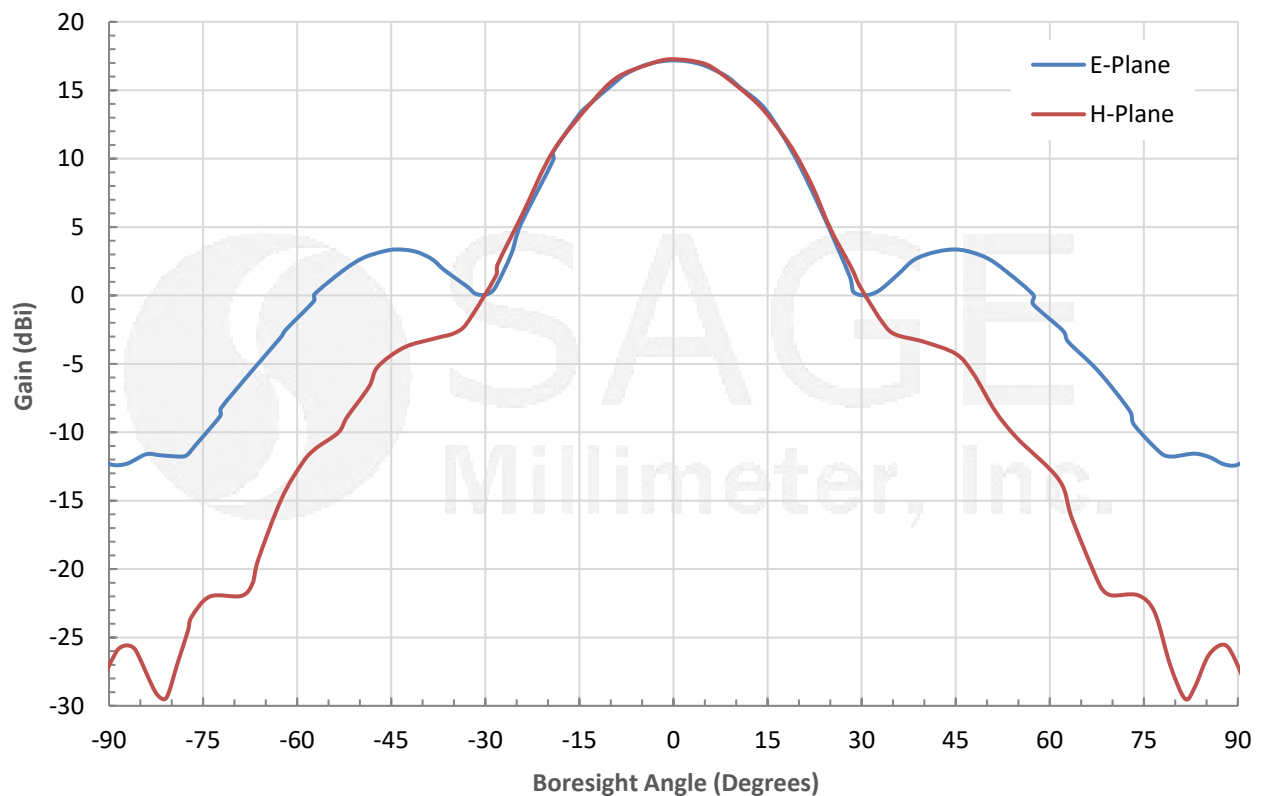



WR-15 Pyramidal Horn Antenna, 17 dBi Gain with 1.85 mm (V) Coax Input

Simulated Antenna Pattern @ 70 GHz

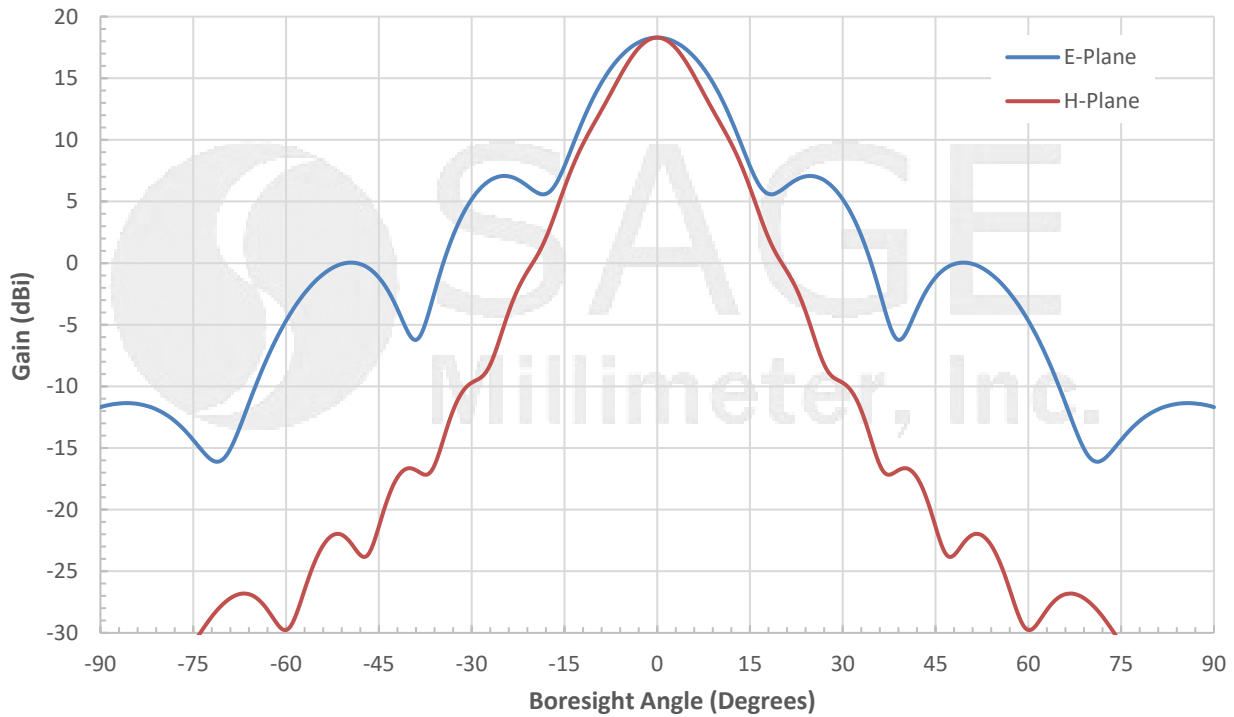

Simulated Gain vs. Frequency

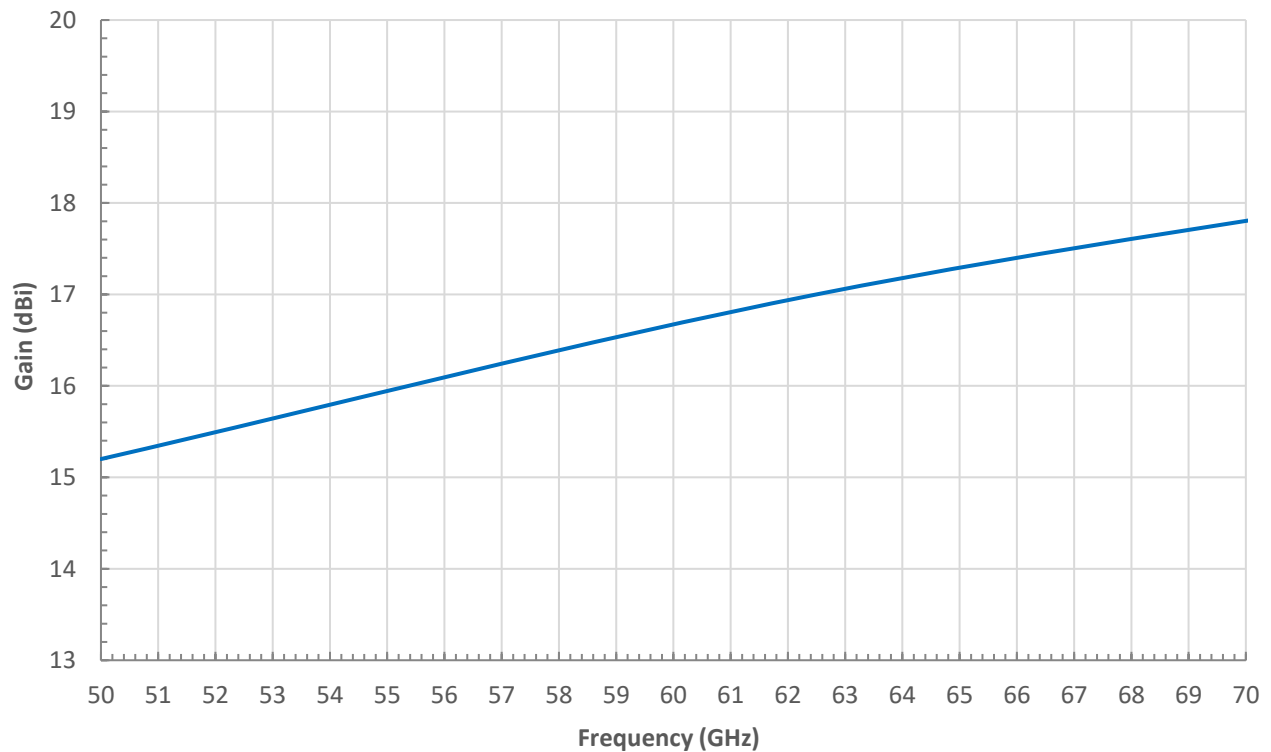



WR-15 Pyramidal Horn Antenna, 17 dBi Gain with 1.85 mm (V) Coax Input

Typical Return Loss vs Frequency

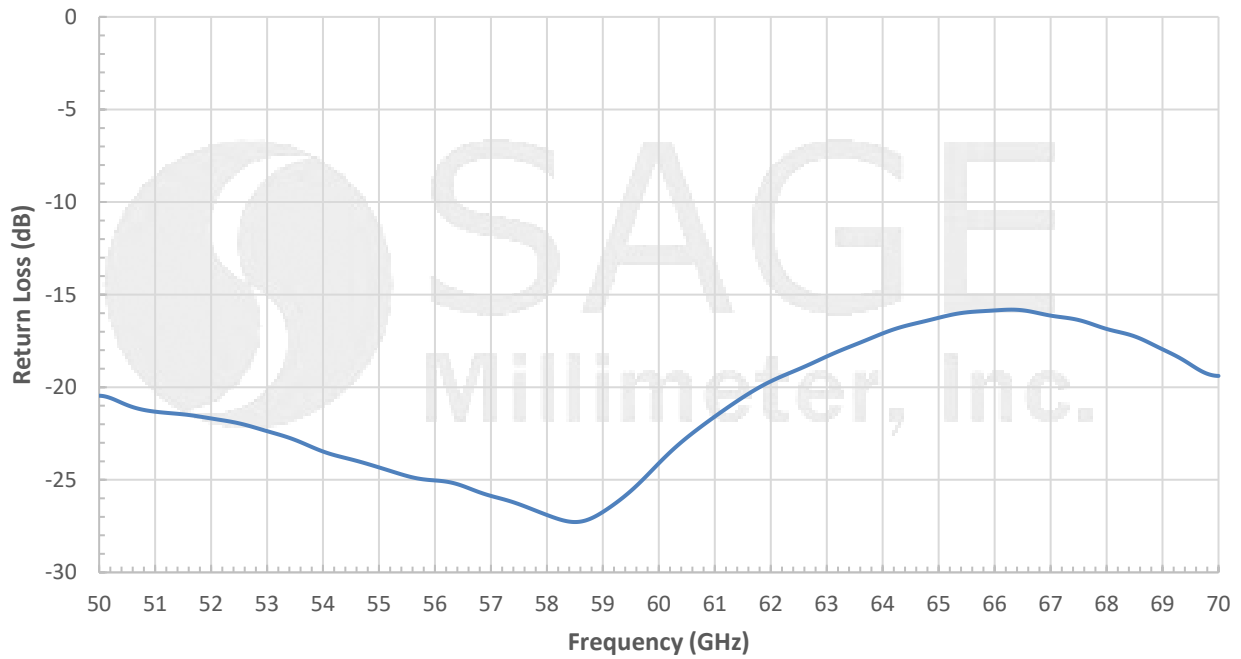

Mechanical Outline: (Unless otherwise specified, all dimensions are in inches [millimeters])

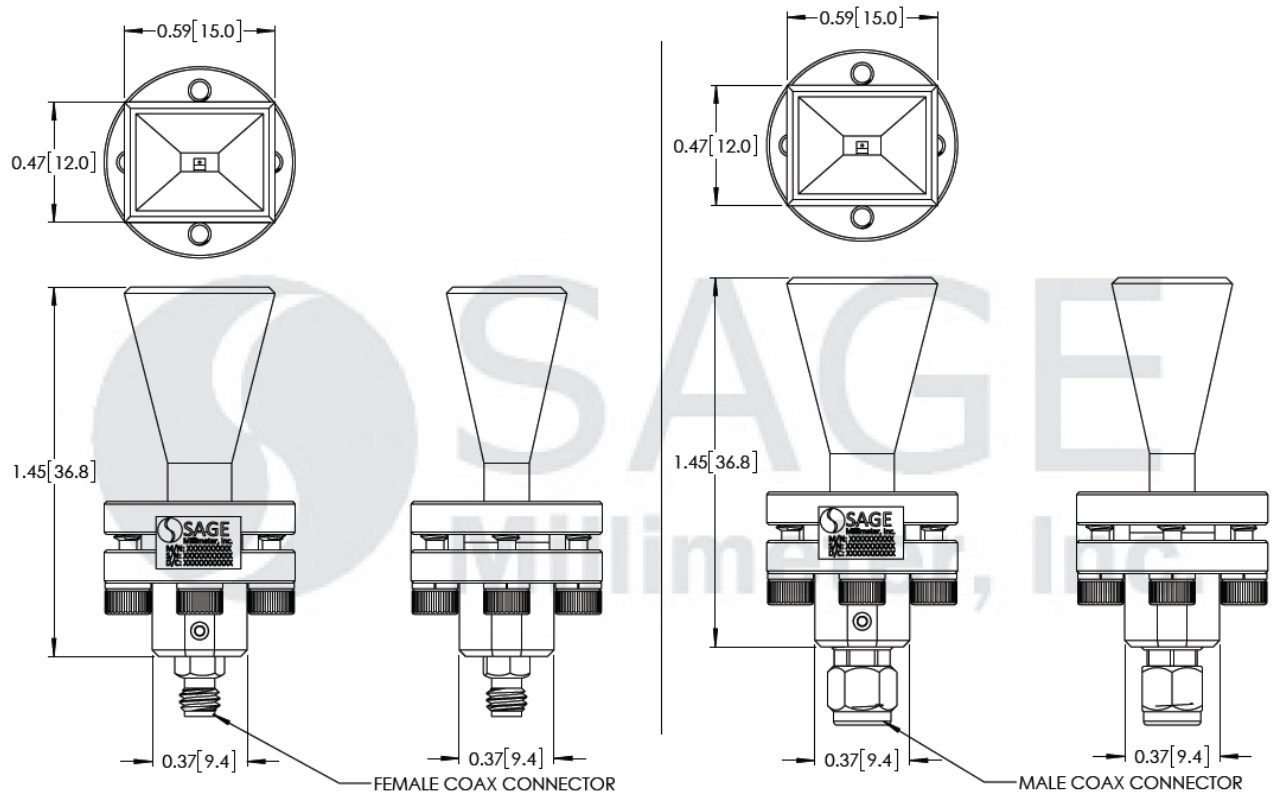



WR-15 Pyramidal Horn Antenna, 17 dBi Gain with 1.85 mm (V) Coax Input

Note:

- This antenna is a mature product. The reasons for only providing simulated data can be found in the following blog [here](#).
- All testing was performed under +25 °C room temperature.
- Eravant reserves the right to change the information presented without notice.

Caution:

- Any foreign objects in the antenna will cause performance degradation and possible device damage.
- Proper torque, 8.0 ± 0.15 inch-pounds (0.90 ± 0.02 Nm), should be applied. **Eravant torque wrench, model SCH-08008-S1, is highly recommended.**

