



WR-15 Pyramidal Horn Antenna, 17 dBi Gain

Description:

Model SAR-1725-15-S2 is a V-band pyramidal horn antenna that operates from 50 GHz to 75 GHz. The antenna offers 15 dBi nominal gain and a typical half power beamwidth of 26 degrees on the E-plane and 25 degrees on the H-plane. The antenna supports linear polarized waveforms. The input of this antenna is a WR-15 waveguide with UG-385/U flange.



Features:

- Rectangular Waveguide Interface
- Precisely Machined and Gold Plated
- Linear Polarization
- High Return Loss

Applications:

- Antenna Ranges
- Antenna Gain Measurements
- System Setups

Electrical Specifications:

Parameter	Minimum	Typical	Maximum
Frequency	50 GHz		75 GHz
Gain		17 dBi	
Polarization		Linear	
3 dB Beamwidth, E-Plane		26°	
3 dB Beamwidth, H-Plane		25°	
Sidelobes, E-Plane		-13 dB	
Sidelobes, H-Plane		-36 dB	
Return Loss		23 dB	
Specification Temperature		+25 °C	
Operation Temperature	-40 °C		+85 °C

Mechanical Specifications:

Item	Specification
Antenna Port	WR-15 Waveguide
Flange Type	UG-385/U Flange
Size	1.00" (L) X 0.59" (W) X 0.47" (H)
Material	Brass
Finish	Gold Plated
Weight	0.6 Oz
Outline	AR-V17





WR-15 Pyramidal Horn Antenna, 17 dBi Gain

Simulated Antenna Patterns @ 50 GHz

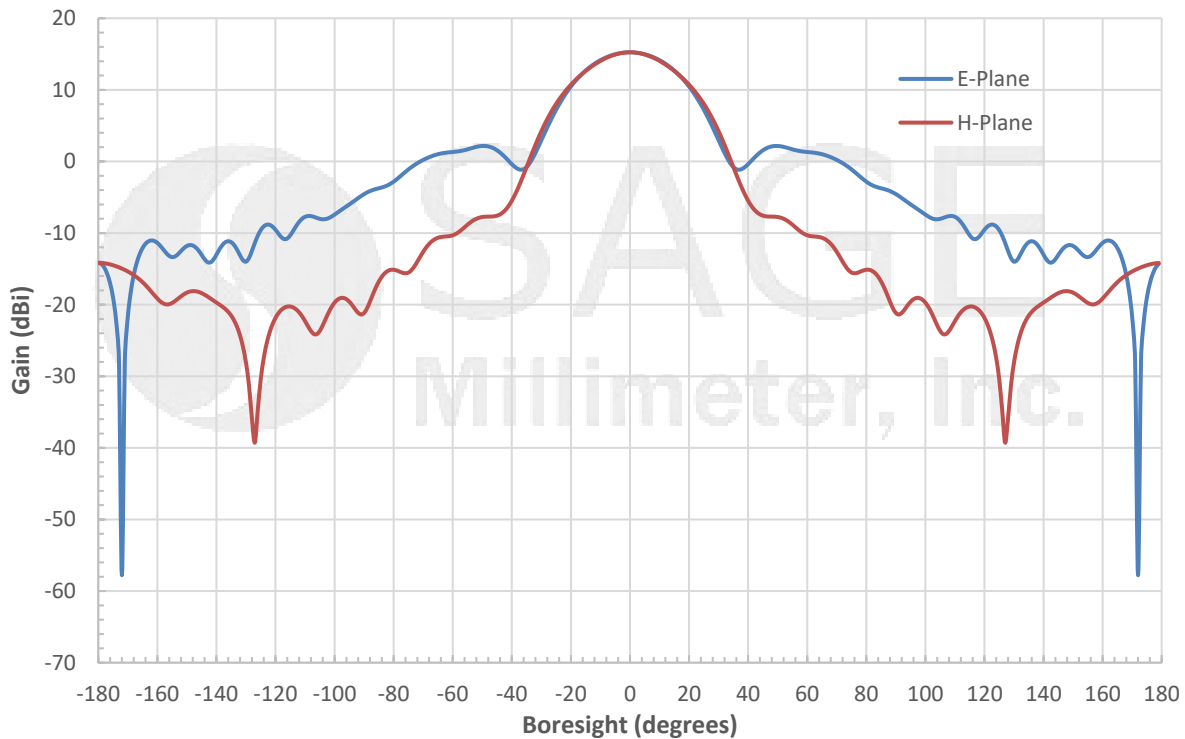

Simulated Antenna Patterns @ 62.5 GHz

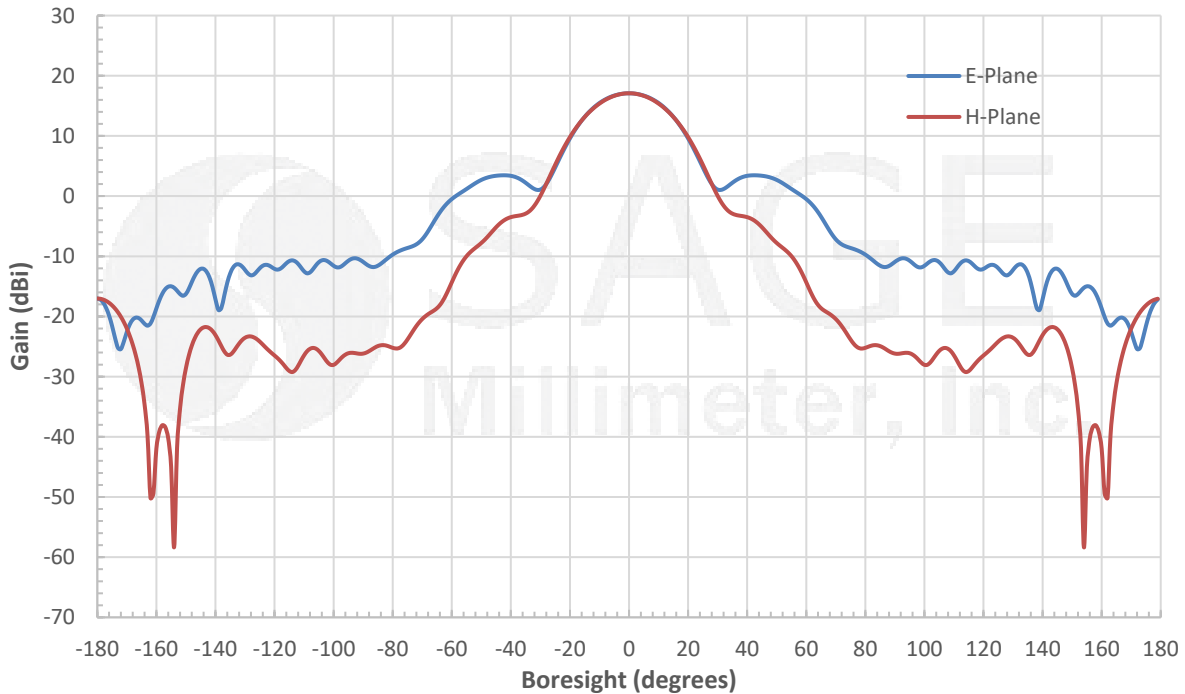



WR-15 Pyramidal Horn Antenna, 17 dBi Gain

Simulated Antenna Patterns @ 75 GHz

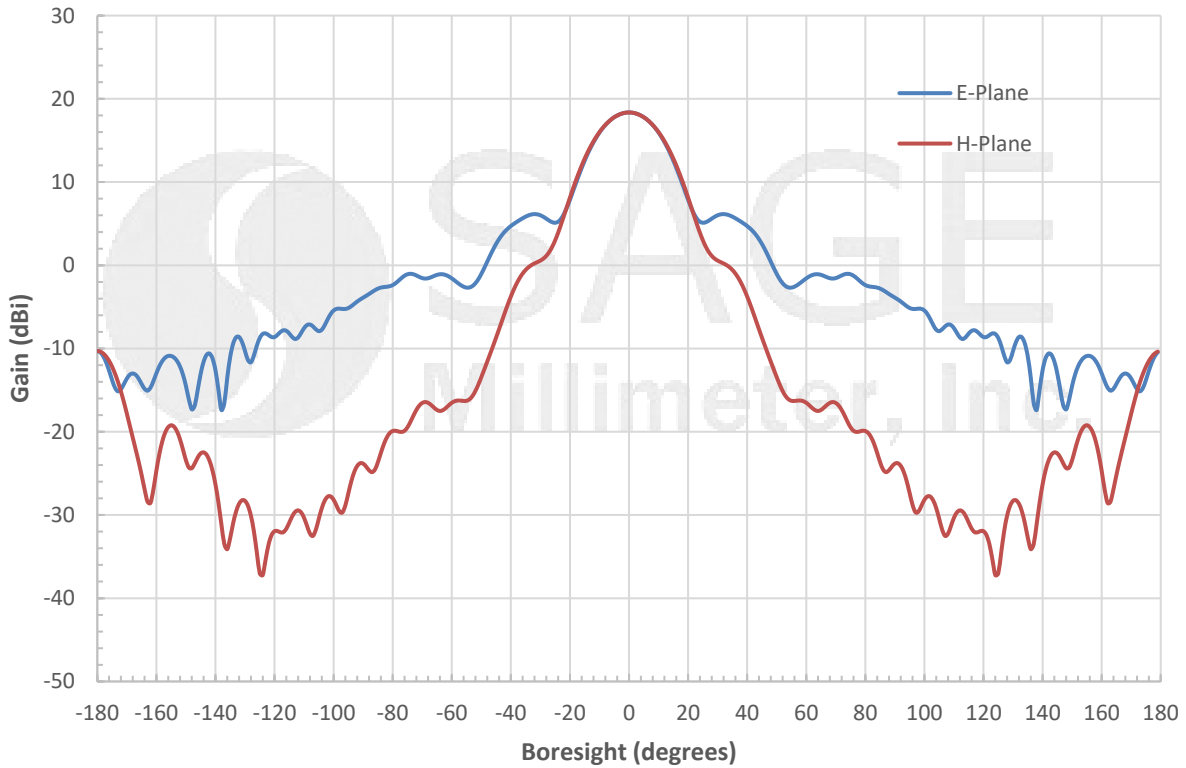

Simulated Gain vs. Frequency

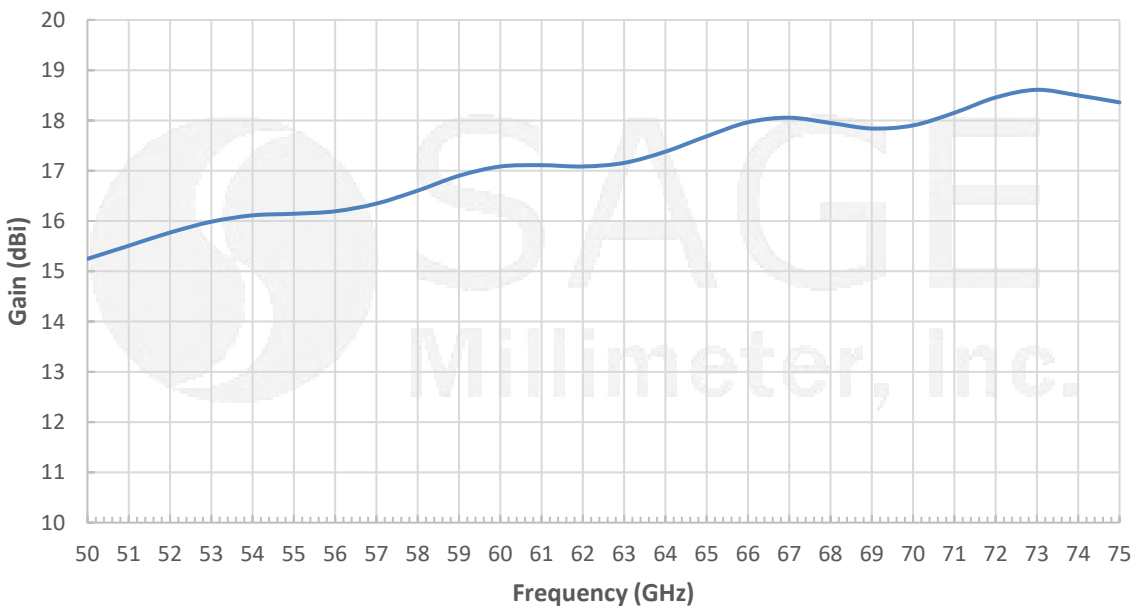



WR-15 Pyramidal Horn Antenna, 17 dBi Gain

Simulated Return Loss vs. Frequency

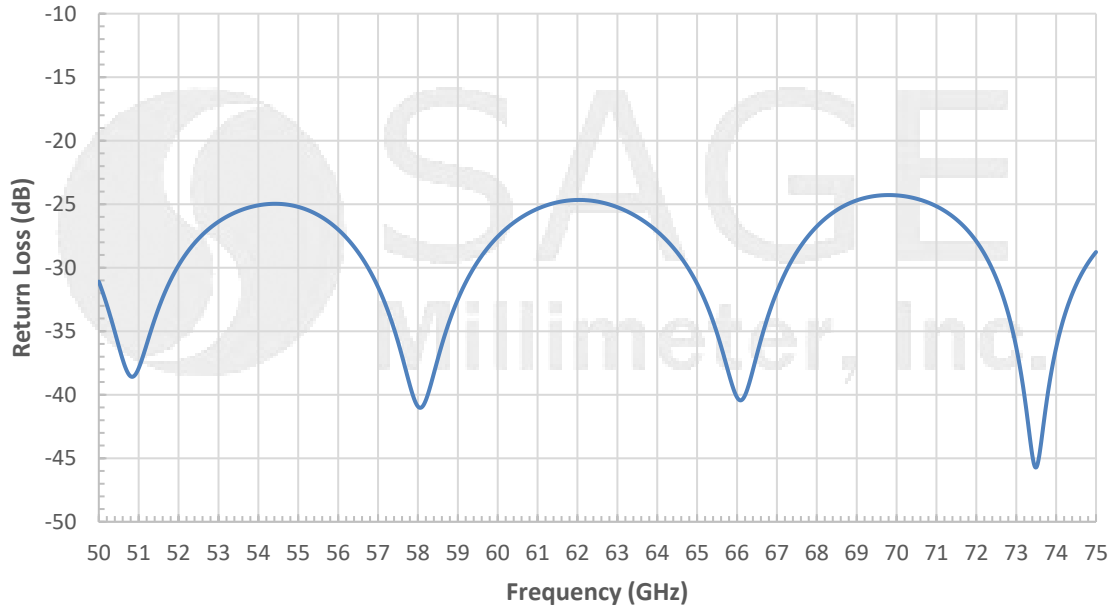

Mechanical Outline: (Unless otherwise specified, all dimensions are in inches [millimeters])

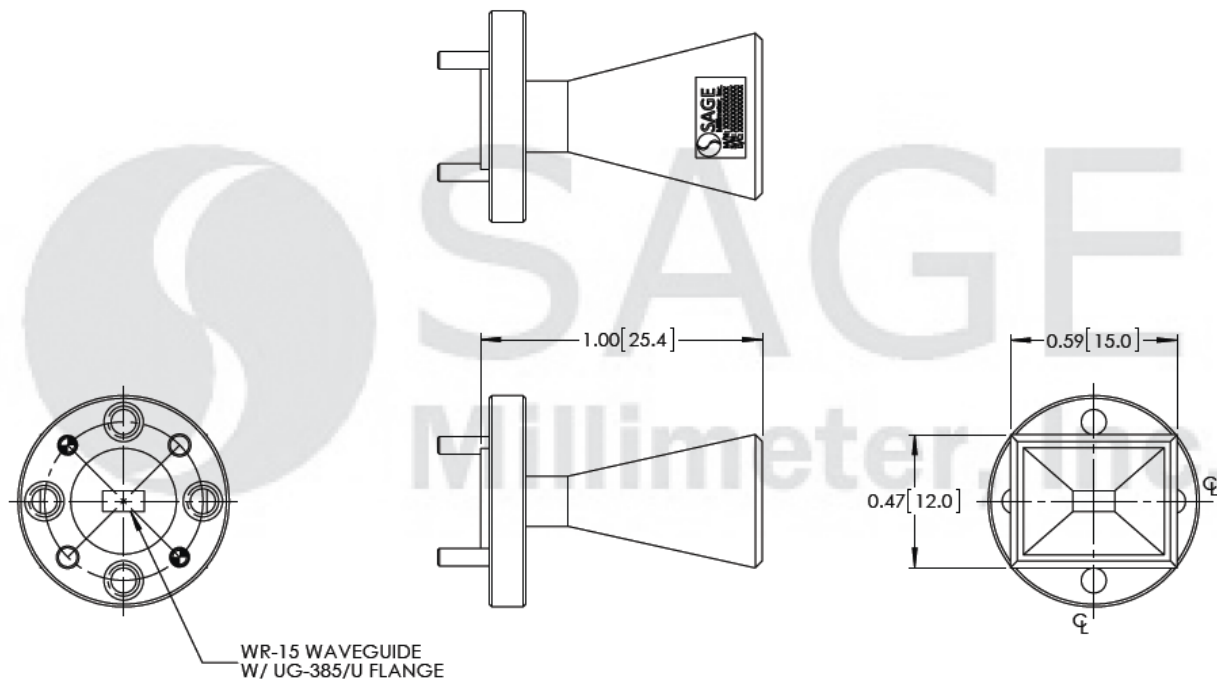

WR-15 Pyramidal Horn Antenna, 17 dBi Gain

Note:

- This antenna is a mature product. The reasons for only providing simulated data can be found in the following blog [here](#).
- Eravant reserves the right to change the information presented without notice.

Caution:

- Any foreign objects in the waveguide will cause performance degradation and possible device damage.

