

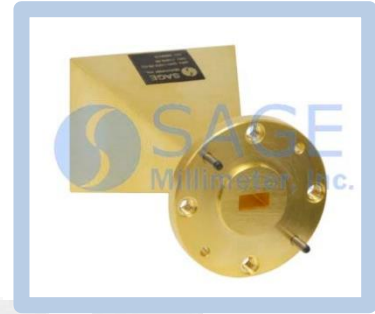

WR-19 Pyramidal Horn Antenna, 15 dBi Gain

Description:

Model SAR-1532-19-S2 is a U-band pyramidal horn antenna that operates from 40 GHz to 60 GHz. The antenna offers 15 dBi nominal gain and a typical half power beamwidth of 32 degrees on the E-plane and 32 degrees on the H-plane. The antenna supports linear polarized waveforms. The input of this antenna is a WR-19 waveguide with UG-383/U-M flange.



Features:

- Rectangular Waveguide Interface
- Precisely Machined and Gold Plated
- Linear Polarization
- High Return Loss

Applications:

- Antenna Ranges
- Antenna Gain Measurements
- System Setups

Electrical Specifications:

Parameter	Minimum	Typical	Maximum
Frequency	40 GHz		60 GHz
Gain		15 dBi	
Polarization	Linear		
3 dB Beamwidth, E-Plane		32°	
3 dB Beamwidth, H-Plane		32°	
Sidelobes, E-Plane		-14 dB	
Sidelobes, H-Plane		-20 dB	
Return Loss		20 dB	
Specification Temperature		+25 °C	
Operation Temperature	-40 °C		+85 °C

Mechanical Specifications:

Item	Specification
Antenna Port	WR-19 Waveguide
Flange Type	UG-383/U-M Flange
Material	Brass
Finish	Gold Plated
Weight	1.4 Oz
Size	1.0" (L) X 1.125" (Ø)
Outline	AR-U15





WR-19 Pyramidal Horn Antenna, 15 dBi Gain

Simulated Antenna Patterns @ 40 GHz

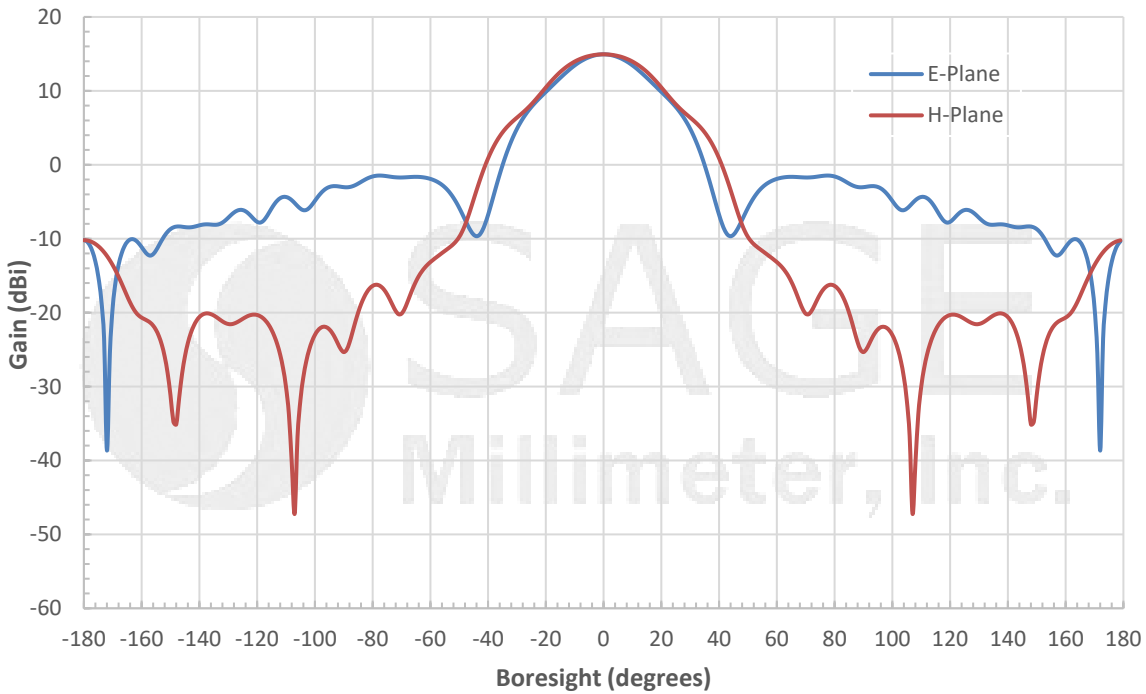

Simulated Antenna Patterns @ 50 GHz

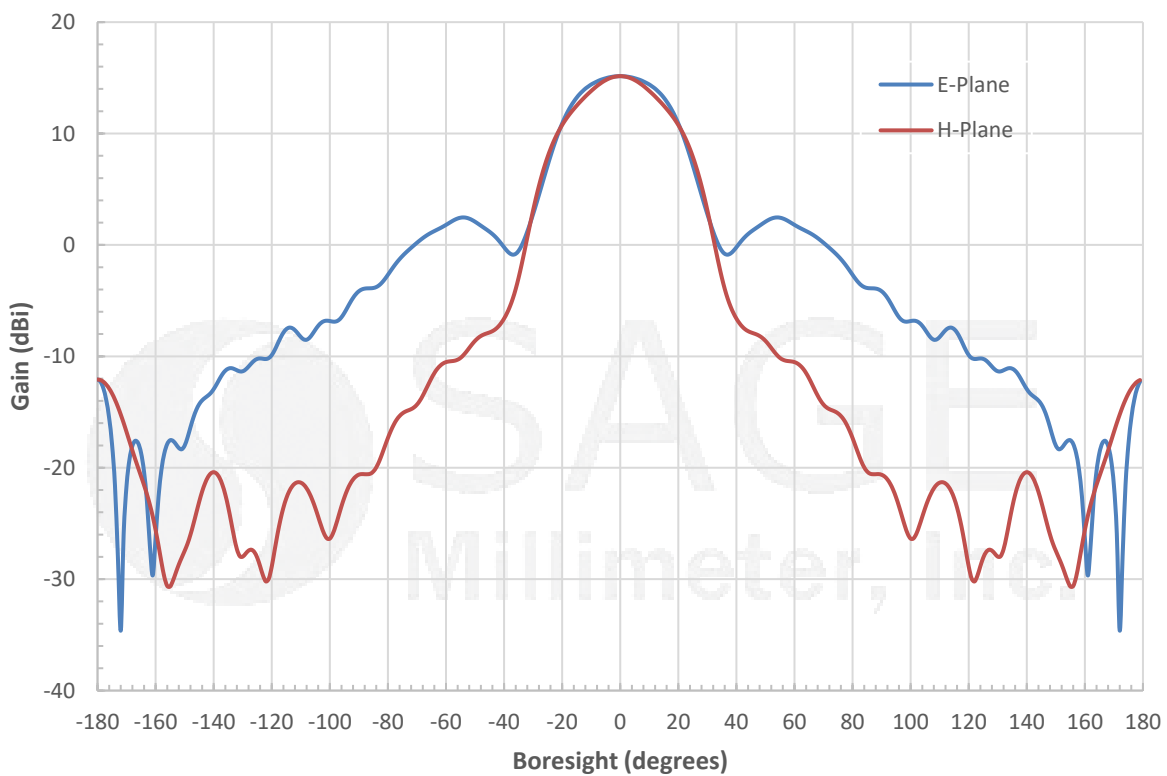



WR-19 Pyramidal Horn Antenna, 15 dBi Gain

Simulated Antenna Patterns @ 60 GHz

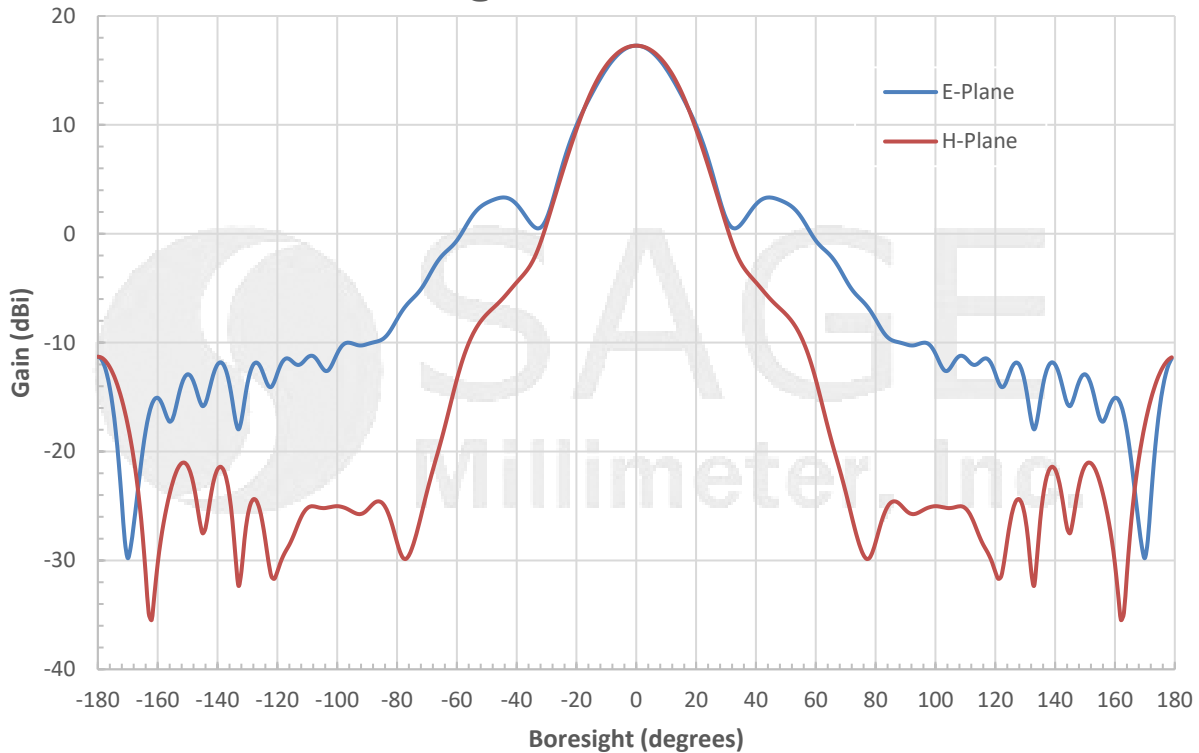

Simulated Return Loss vs. Frequency

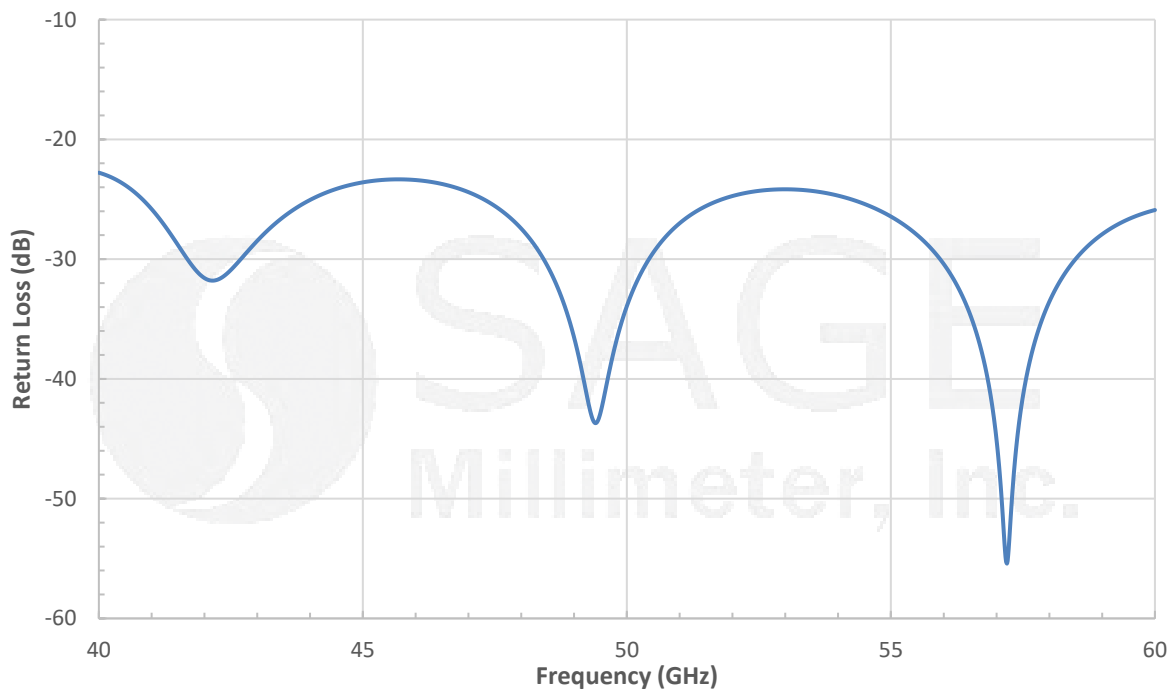



WR-19 Pyramidal Horn Antenna, 15 dBi Gain

Simulated Gain vs. Frequency

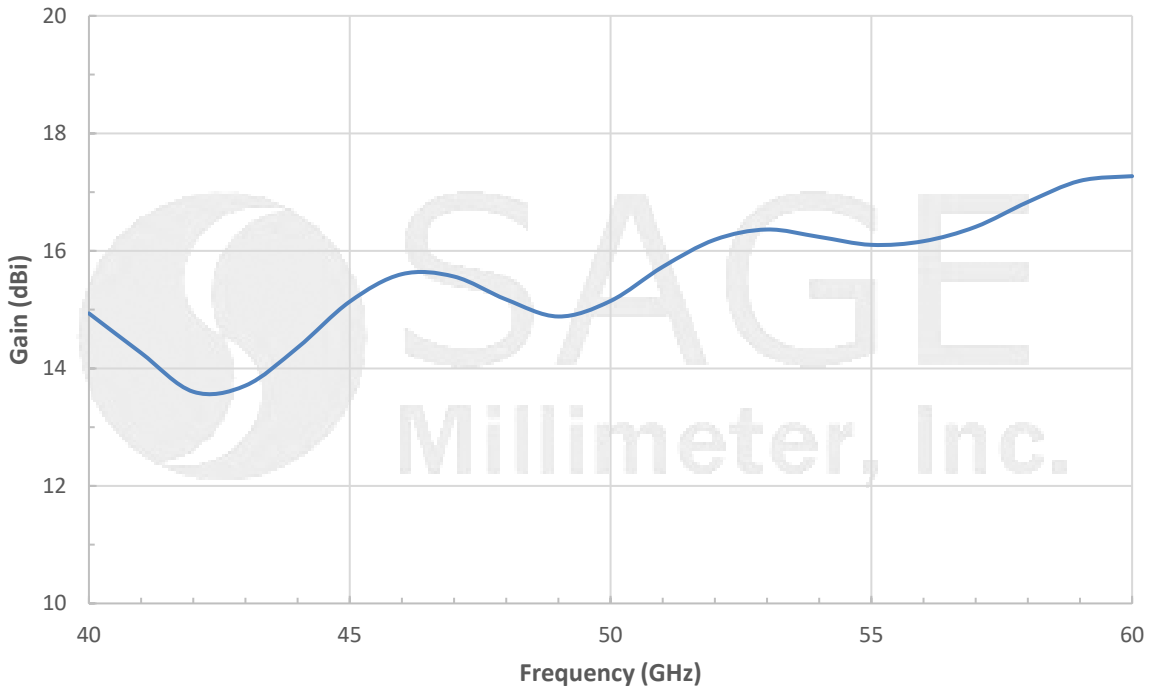

Mechanical Outline: (Unless otherwise specified, all dimensions are in inches [millimeters])

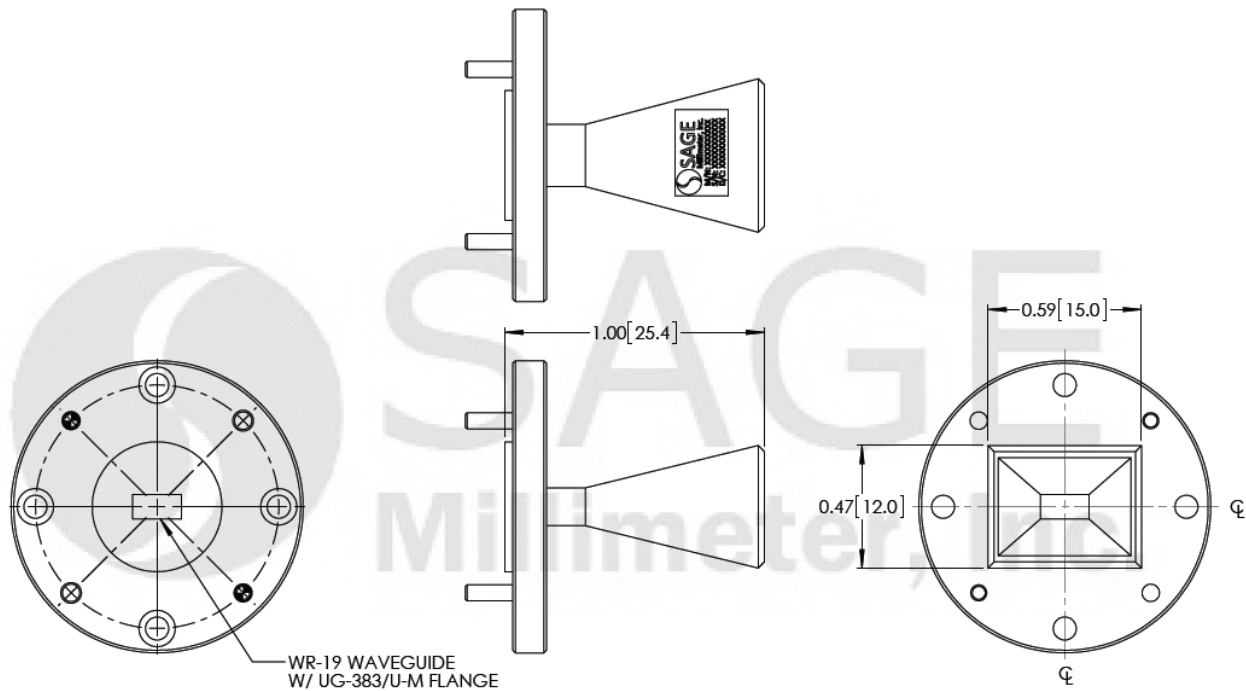



WR-19 Pyramidal Horn Antenna, 15 dBi Gain

Note:

- This antenna is a mature product. The reasons for only providing simulated data can be found in the following blog [here](#).
- Eravant reserves the right to change the information presented without notice.

Caution:

- Any foreign objects in the waveguide will cause performance degradation and possible device damage.

