



U-Band Omnidirectional Antenna, 360 Degree, 4.0 dBi Gain

Description:

Model SAO-4036030415-19-S1 is a full band, WR-19 omnidirectional antenna that operates between 40 and 60 GHz. This vertically polarized antenna offers 360 degrees azimuth coverage with a 4 dBi typical gain and ± 2 dB nominal gain flatness. The antenna features a half power beamwidth of 15 degrees in the vertical direction.



Features:

- 360° Azimuth Coverage
- 15° Vertical 3 dB Beamwidth
- Vertically Polarized
- Full Band Operation

Applications:

- Communication Links
- EW Systems
- Indoor Local Area Networks

Electrical Specifications:

Parameter	Minimum	Typical	Maximum
Frequency	40 GHz		60 GHz
Gain		4 dBi	
Azimuth Gain Variation		± 2 dBi	
Azimuth Beamwidth		360°	
3 dB Vertical Beamwidth		15°	
Return Loss		10 dB	
Power Handling		150 W (CW)	
Specification Temperature		+25 °C	
Operating Temperature	-40 °C		+85 °C

Mechanical Specifications:

Item	Specification
RF Port	WR-19 Waveguide with UG-383/U-M Flange
Body Material	Aluminum
Lens Material	HDPE
Finish	Gold Plated
Weight	0.8 Oz
Size	1.27" (H) x 2.58" (ϕ)
Outline	AO-U04-015





U-Band Omnidirectional Antenna, 360 Degree, 4.0 dBi Gain

Simulated E-Plane Antenna Pattern @ 40 GHz

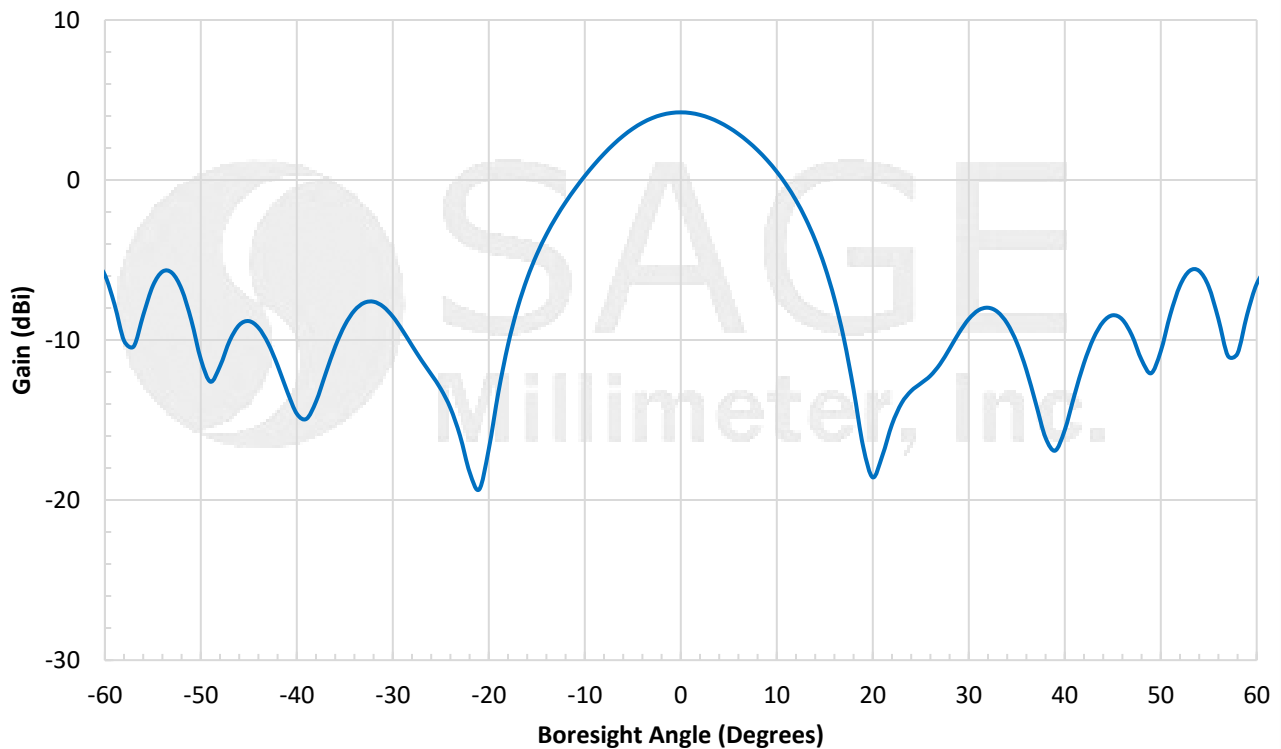

Simulated E-Plane Antenna Pattern @ 50 GHz

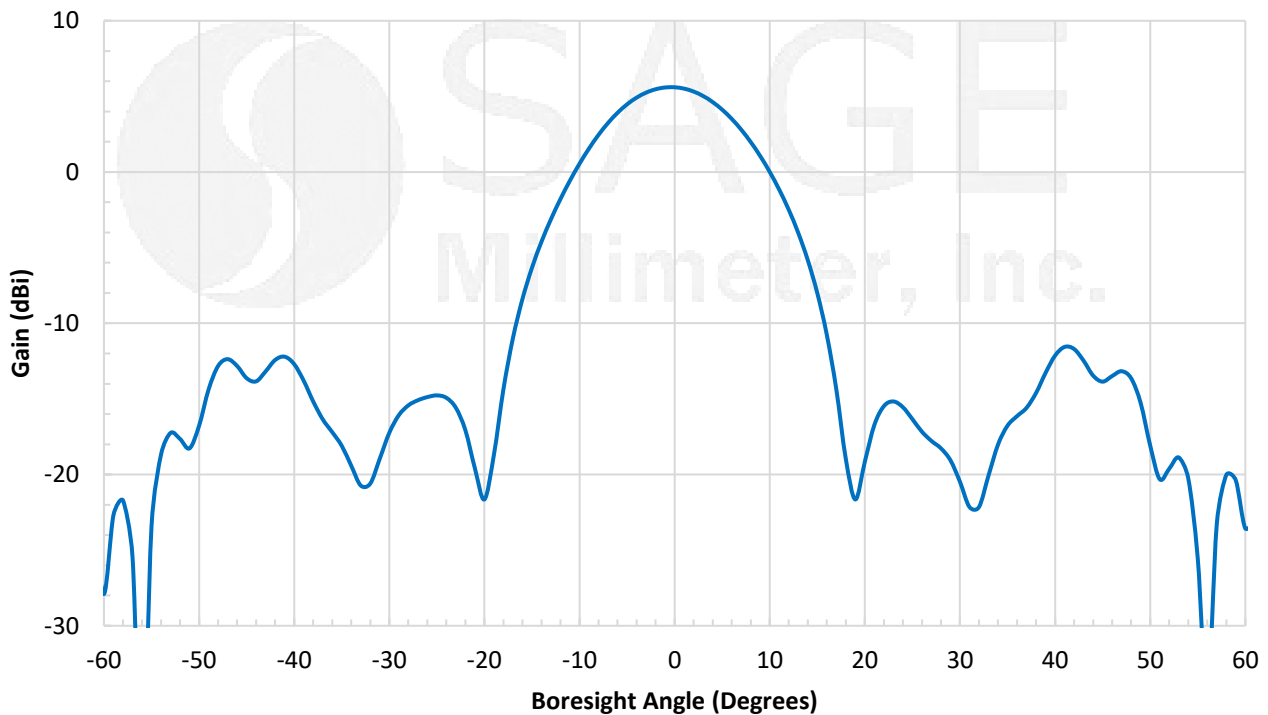



U-Band Omnidirectional Antenna, 360 Degree, 4.0 dBi Gain

Simulated E-Plane Antenna Pattern @ 60 GHz

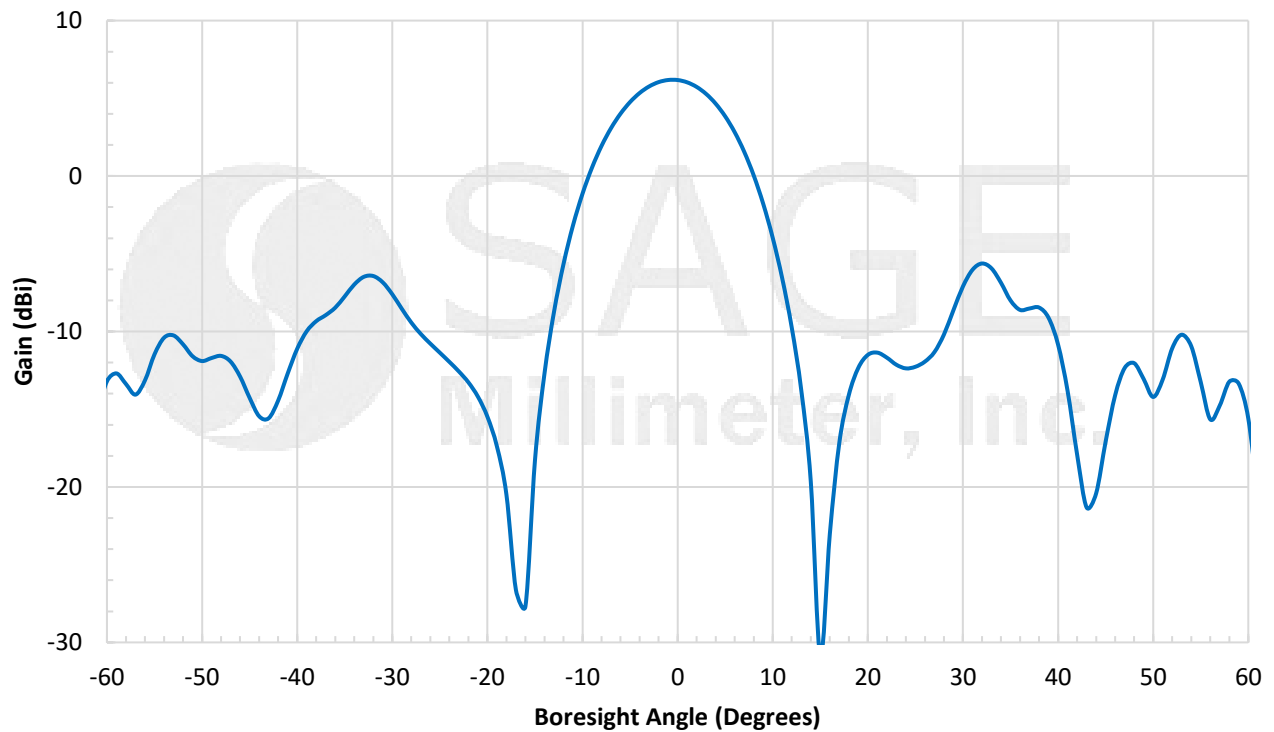

Simulated Gain vs. Frequency

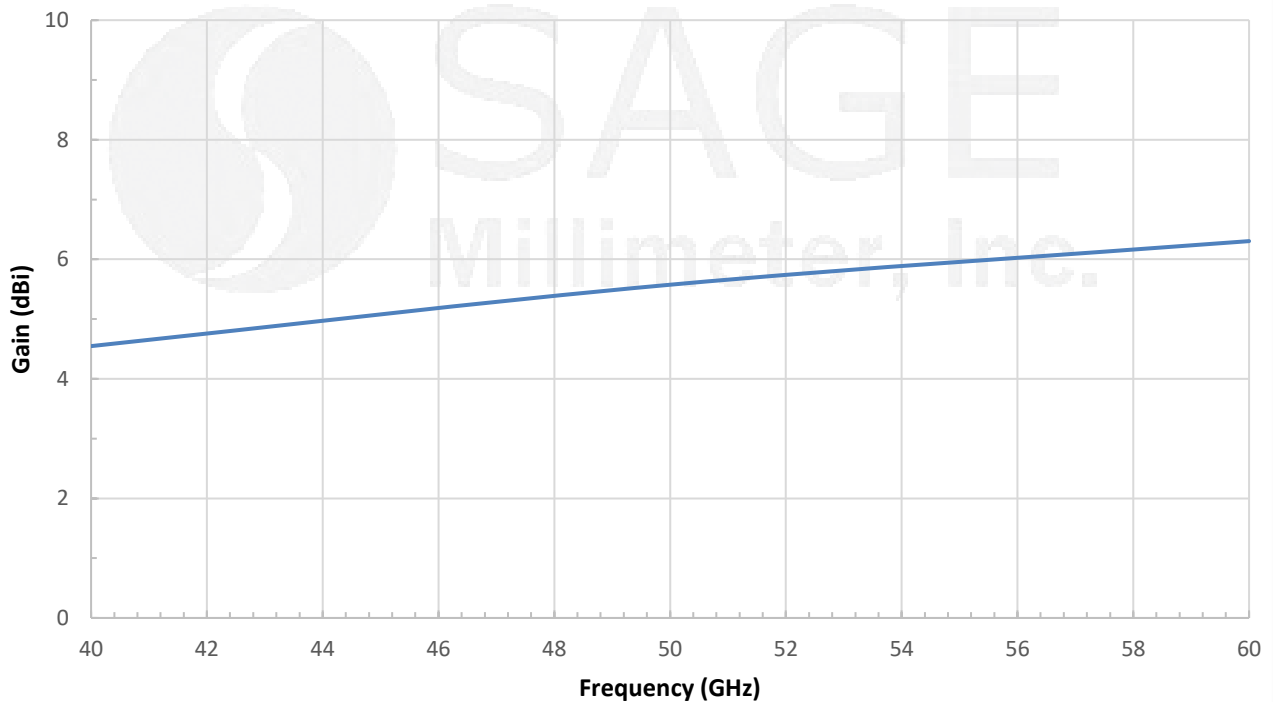



U-Band Omnidirectional Antenna, 360 Degree, 4.0 dBi Gain

Measured Return Loss vs. Frequency

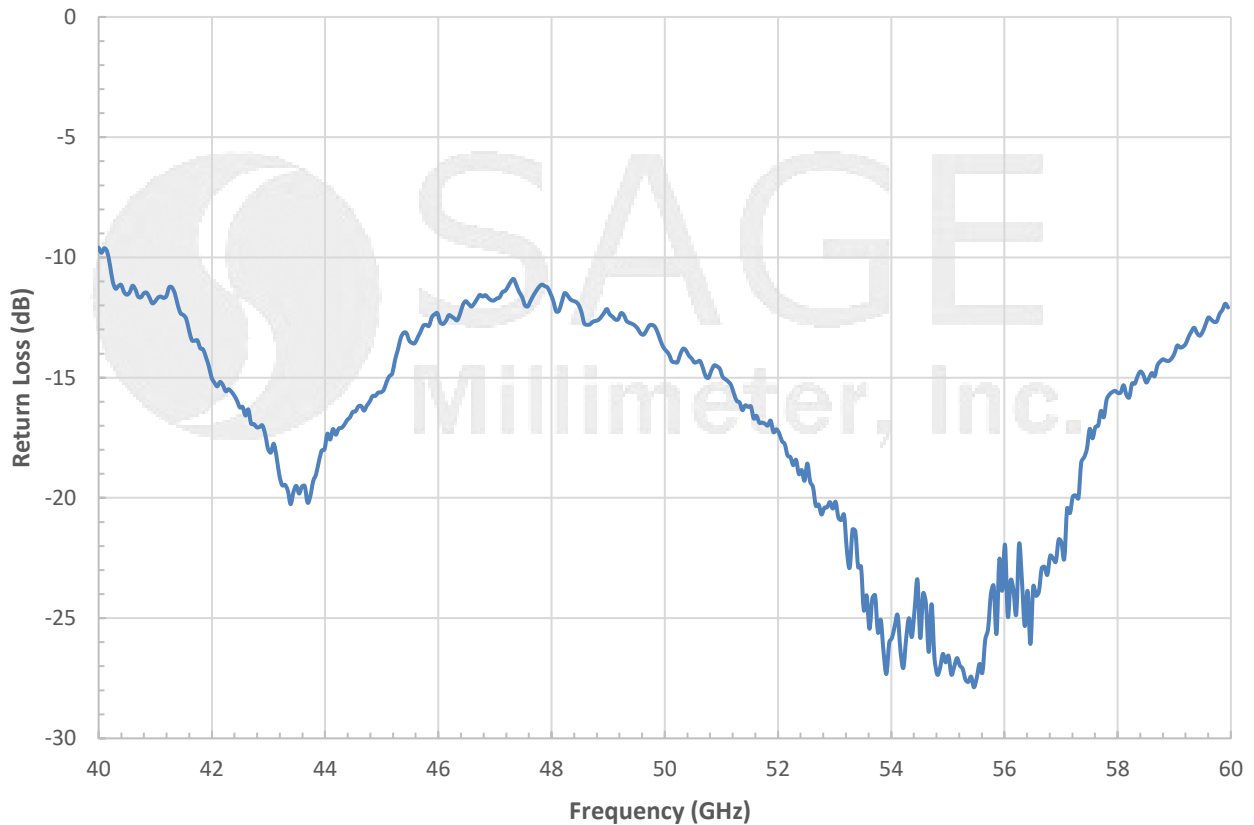

Mechanical Outline: (Unless otherwise specified, all dimensions are in inches [millimeters])

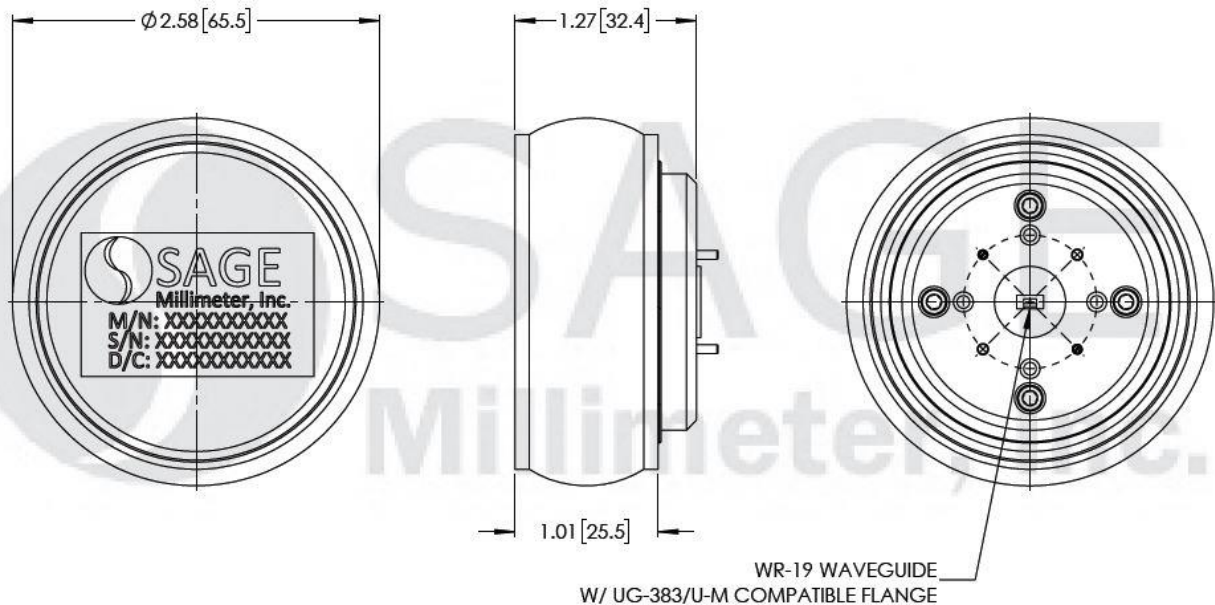



U-Band Omnidirectional Antenna, 360 Degree, 4.0 dBi Gain

Note:

- Return Loss data presented is collected from a sample lot. Actual data may vary unit to unit, slightly.
- All testing was performed under +25°C room temperature.
- Antenna Pattern and Gain data presented are simulated. Actual data may vary unit to unit, slightly.
- SAGE Millimeter, Inc. reserves the right to change the information presented without notice.

Caution:

- Any foreign objects in the antenna will cause performance degradation and possible device damage.

