



## Ka-Band Omnidirectional Antenna, 45 Degree, 3 dBi Gain

### Description:

**Model SAO-2734030345-KF-S1** is a full band, Ka band omnidirectional antenna that covers the frequency range of 26.5 and 40 GHz. This vertically polarized antenna offers 360 degrees azimuth coverage with a 3 dBi typical gain and  $\pm 1$  dB nominal gain flatness. The antenna features a half power beamwidth of 45 degrees in its vertical direction. The RF port of the antenna is equipped with K(F) coaxial connector. The version with WR-28 waveguide interface is offered under model number, **SAO-2734030345-28-S1**.



### Features:

- 360° Azimuth Coverage
- 45° Vertical 3 dB Beamwidth
- Vertically Polarized
- Full Band Operation

### Applications:

- 5G Systems
- Communication Links
- EW Systems
- Indoor Local Area Networks

### Electrical Specifications:

Parameter	Minimum	Typical	Maximum
Frequency Range	26.5 GHz		40.0 GHz
Gain		3 dBi	
Azimuth Gain Variation		$\pm 1$ dB	
Azimuth Beamwidth		360°	
3 dB Vertical Beamwidth		45°	
Return Loss		8 dB	
Power Handling		50 W (CW)	75 W (CW)
Specification Temperature		+25 °C	
Operating Temperature	-40 °C		+85 °C

### Mechanical Specifications:

Item	Specification
Input	2.92 mm (K) Female Connector
Size	1.36" (H) x 1.79" ( $\phi$ )
Body Material	Aluminum
Radome Material	HDPE
Finish	Gold Plating
Weight	1.90 Oz
Outline	AO-AC03-045-E





## Ka-Band Omnidirectional Antenna, 45 Degree, 3 dBi Gain

### Simulated E-Plane Patterns

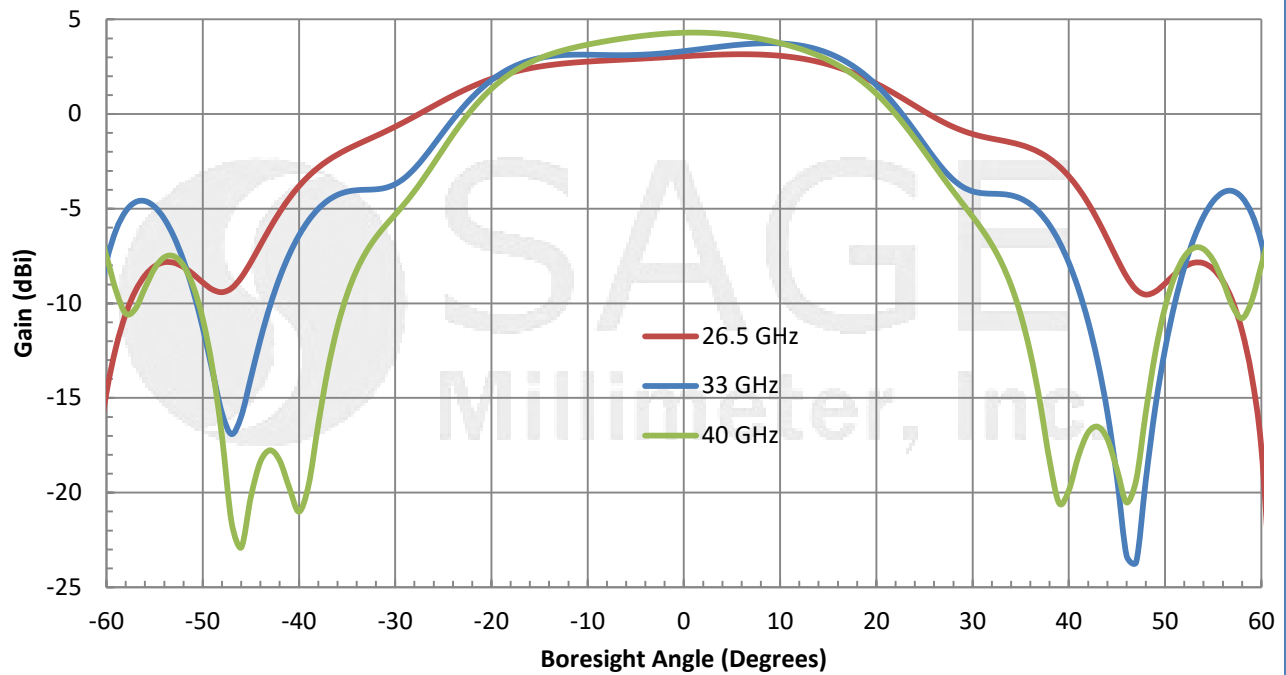

### Simulated H-Plane Patterns

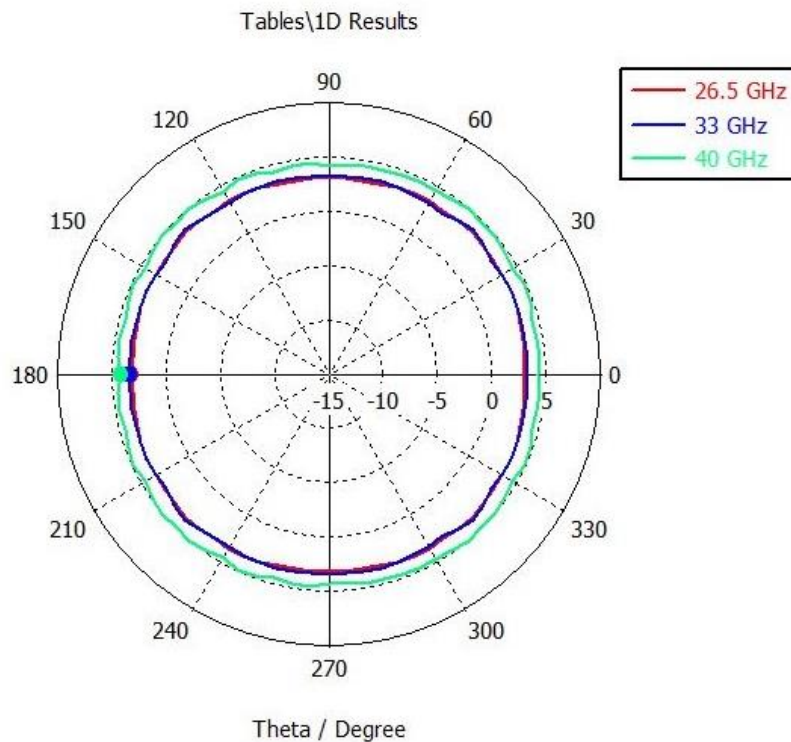



## Ka-Band Omnidirectional Antenna, 45 Degree, 3 dBi Gain

### Typical Gain and Return Loss vs. Frequency

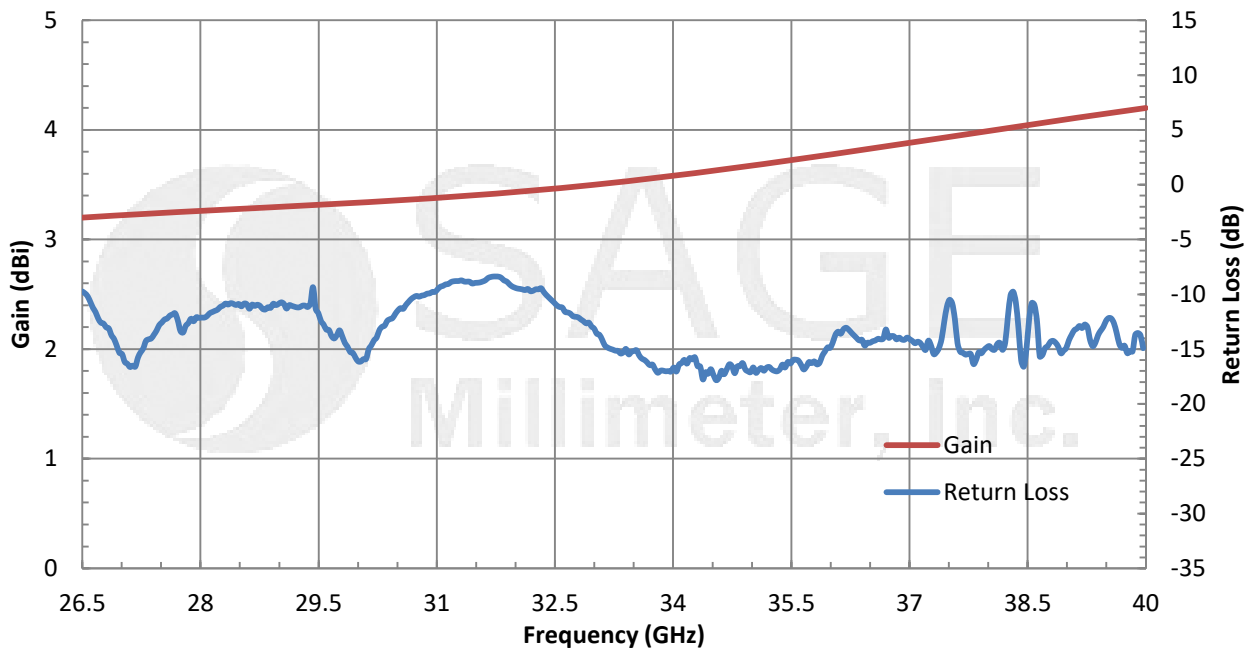

### Mechanical Outline: (Unless otherwise specified, all dimensions are in inches [millimeters])

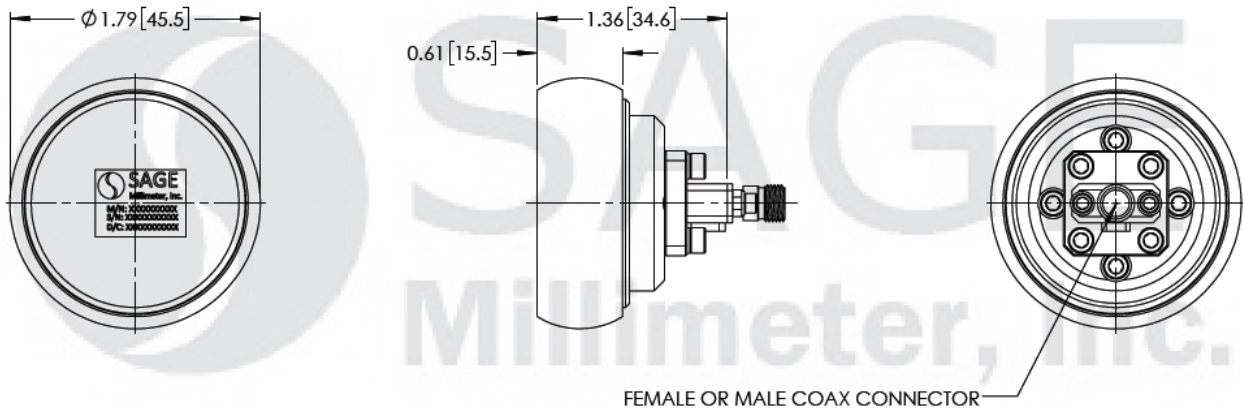

#### Note:

- Return Loss data presented is collected from a sample lot. Actual data may vary unit to unit, slightly.
- Antenna Pattern and Gain data presented is simulated. Actual data may vary, slightly.
- SAGE Millimeter, Inc. reserves the right to change the information presented without notice.

#### Caution:

- Proper torque,  $8.0 \pm 0.15$  inch-pounds ( $0.92 \pm 0.05$  Nm), should be applied. **SAGE Millimeter torque wrench, model SCH-08008-S1, is highly recommended.**

