



W-Band Lens Corrected Antenna

Description:

Model SAL-7531142805-10-S1 is a W-band lens corrected antenna that operates from 75 to 110 GHz. At a center frequency of 94 GHz, the antenna delivers 28 dBi nominal gain, 5.3 degrees typical half power beamwidth on the E-plane, and 6.5 degrees typical half power beamwidth on the H-plane. The antenna employs a low loss lens to offer excellent aperture efficiency and low sidelobe levels. The lens corrected antenna is equipped with a standard WR-10 waveguide and UG-387/U-M flange as its input port. It supports linear polarized waveforms.



Features:

- Center Fed
- Low Sidelobes
- Low Cross Polarization

Applications:

- Radar Systems
- Communication Systems
- Sensor Systems

Electrical Specifications:

Parameter	Minimum	Typical	Maximum
Frequency	75 GHz	94 GHz	110 GHz
Gain		28 dBi	
3 dB Beamwidth, E-Plane		5.3°	
3 dB Beamwidth, H-Plane		6.5°	
Sidelobes, E-Plane		-17 dB	
Sidelobes, H-Plane		-25 dB	
Polarization	Linear		
Return Loss		25 dB	
Specification Temperature		+25 °C	
Operating Temperature	-45 °C		+85 °C

Mechanical Specifications:

Item	Specification
Antenna Port	WR-10 Waveguide with UG-387/U-M Flange
Lens Diameter	1.54"
Dimensions	1.64" (Ø) x 2.84" (L)
Horn Material	Aluminum
Finish	Gold Plated
Weight	2.3 Oz
Outline	AL-RW28





W-Band Lens Corrected Antenna

Simulated Gain vs. Frequency

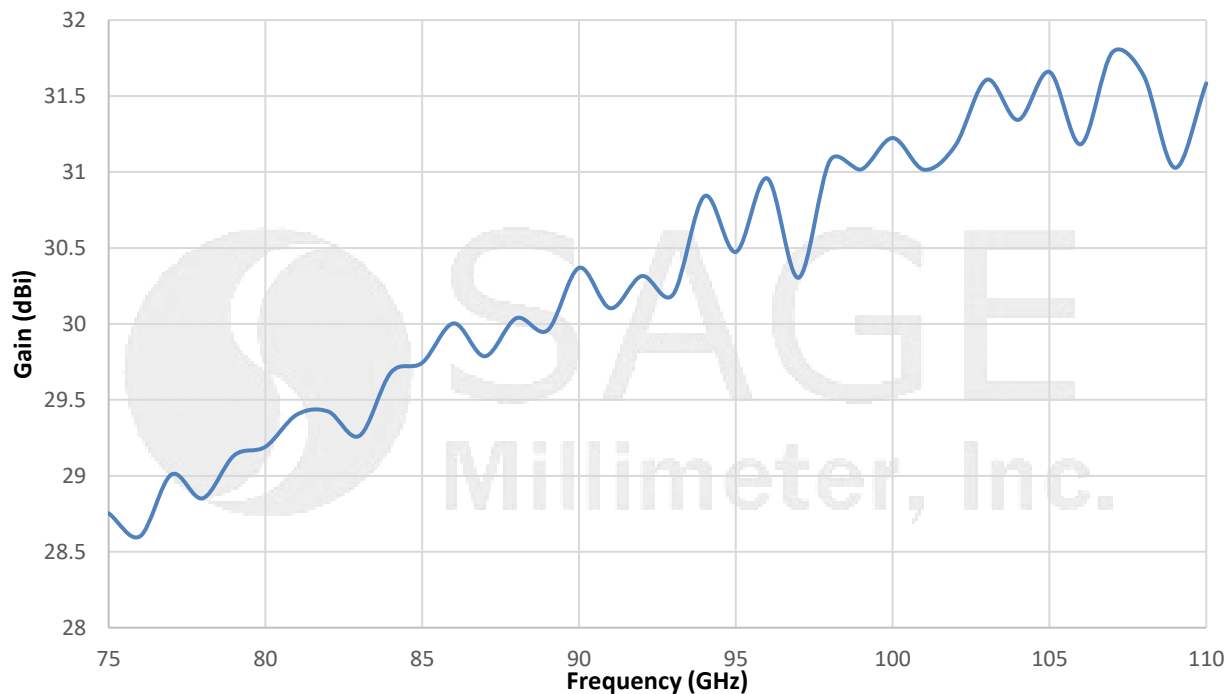

Simulated Antenna Pattern @ 75 GHz

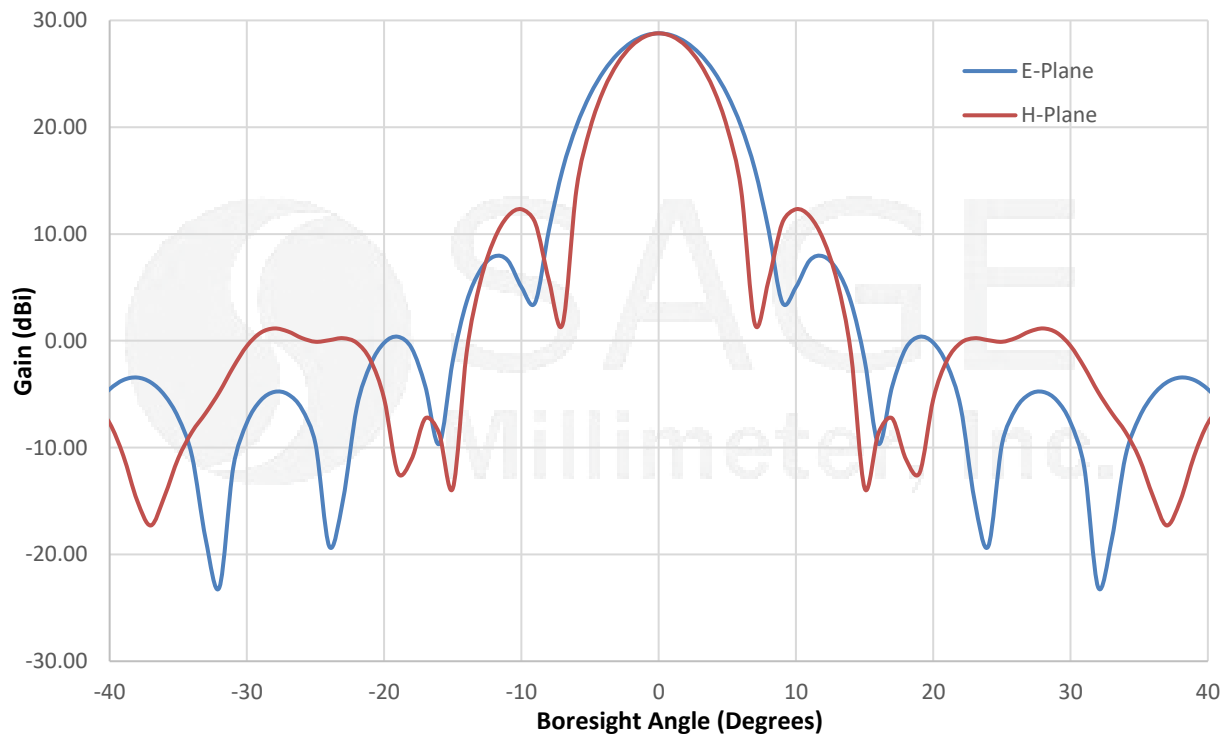



W-Band Lens Corrected Antenna

Simulated Antenna Pattern @ 93 GHz

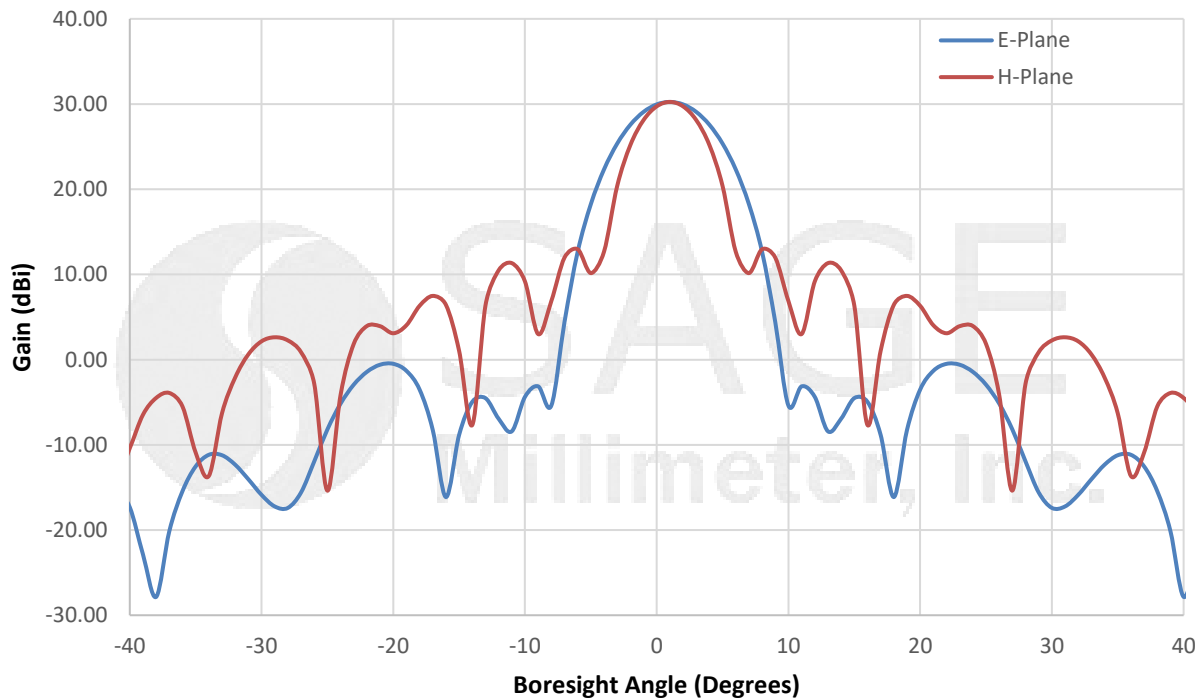

Simulated Antenna Pattern @ 110 GHz

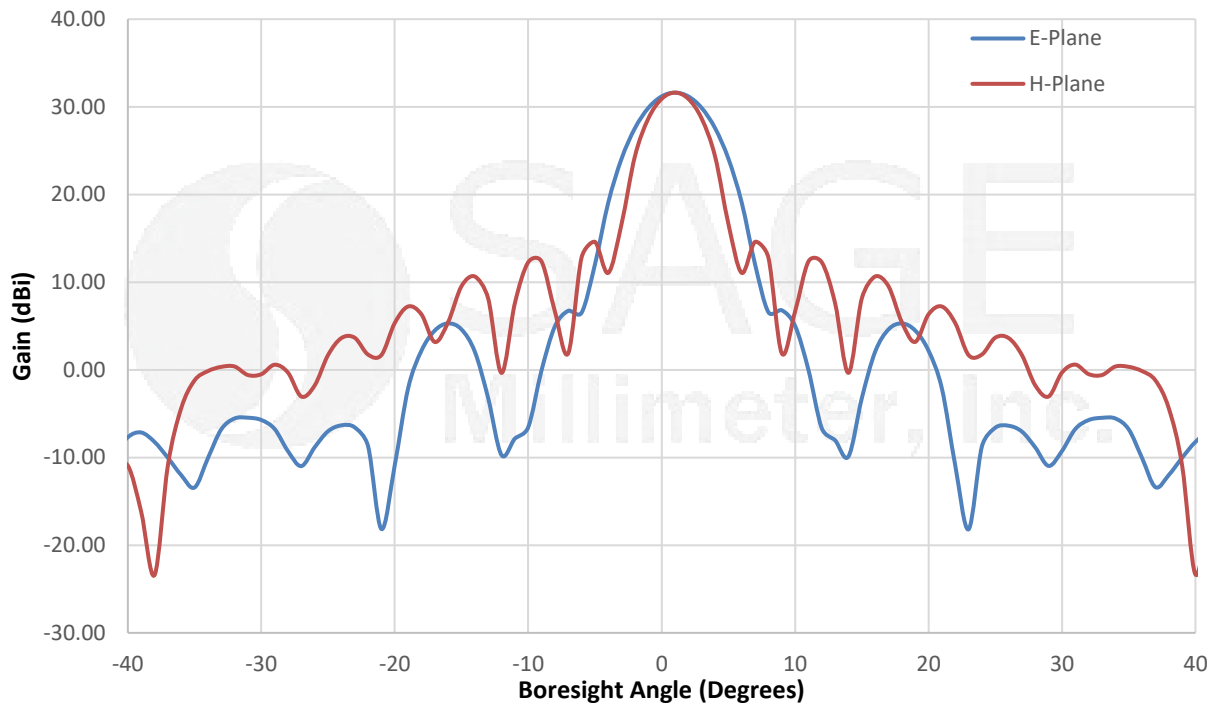



W-Band Lens Corrected Antenna

Simulated Return Loss vs. Frequency

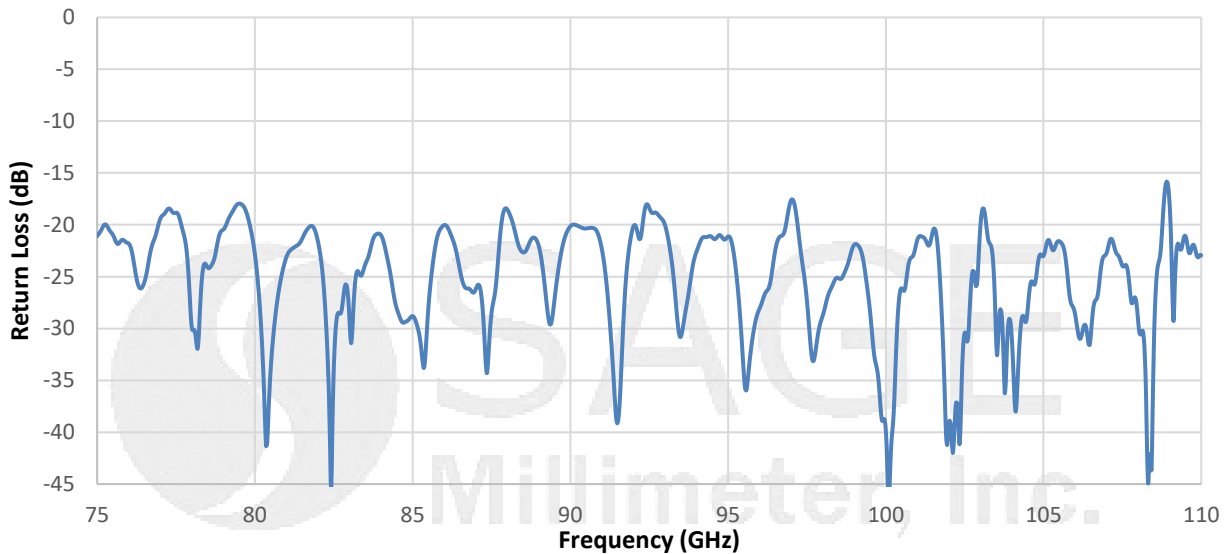

Mechanical Outline: (Unless otherwise specified, all dimensions are in inches)

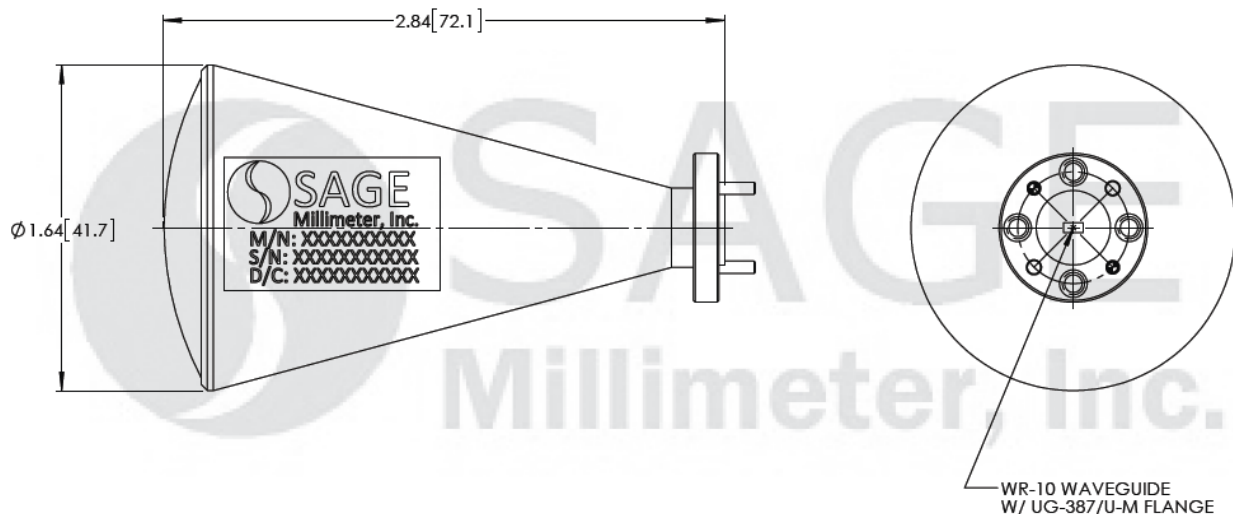

Note:

- All data presented is simulated. Actual data may vary, slightly.
- SAGE Millimeter, Inc. reserves the right to change the information presented without notice.

Caution:

- Foreign objects in the waveguide will affect the antenna performance and may damage the antenna.

