



W Band Gaussian Optics Antenna

Description:

Model SAG-8831044801-094-S1 is a 12" W-band Gaussian antenna that operates from 88 to 100 GHz. The Gaussian antenna delivers a 48 dBi nominal gain and 0.8 degree half power beamwidth. The antenna supports both linear and circular polarized waveforms and employs a corrugated feed horn to offer excellent aperture efficiency, high cross polarization rejections, and low sidelobe levels. This model is equipped with a 0.094" diameter circular waveguide and UG-387/U-M anti-cocking flange as its input port. By adding a mode transition, Eravant model number SWT-10094-SB, the input port becomes a standard WR-10 waveguide, which can only support linear polarized waveforms.



Features:

- Center Fed
- Low Sidelobes
- Low Cross Polarization

Applications:

- Radar Systems
- Communication Systems
- Plasma Systems

Electrical Specifications:

Parameter	Minimum	Typical	Maximum
Frequency	88 GHz	94 GHz	100 GHz
Gain		48 dBi	
3 dB Beamwidth		0.8°	
Sidelobes		-25 dB	
Polarization	Linear and Circular		
Return Loss		15 dB	
Specification Temperature		+25 °C	
Operating Temperature	-40°C		+85 °C

Mechanical Specifications:

Item	Specification
Antenna Port	0.094" Dia Circular Waveguide with UG-387/U-M Flange
Lens Diameter	12.0"
Dimensions	13.00" (Ø) x 16.29" (L)
Material	Aluminum
Finish	Black Anodized
Weight	19.5 lb
Outline	AG-CW48-094-A





W Band Gaussian Optics Antenna

Simulated Antenna Patterns @ 88 GHz

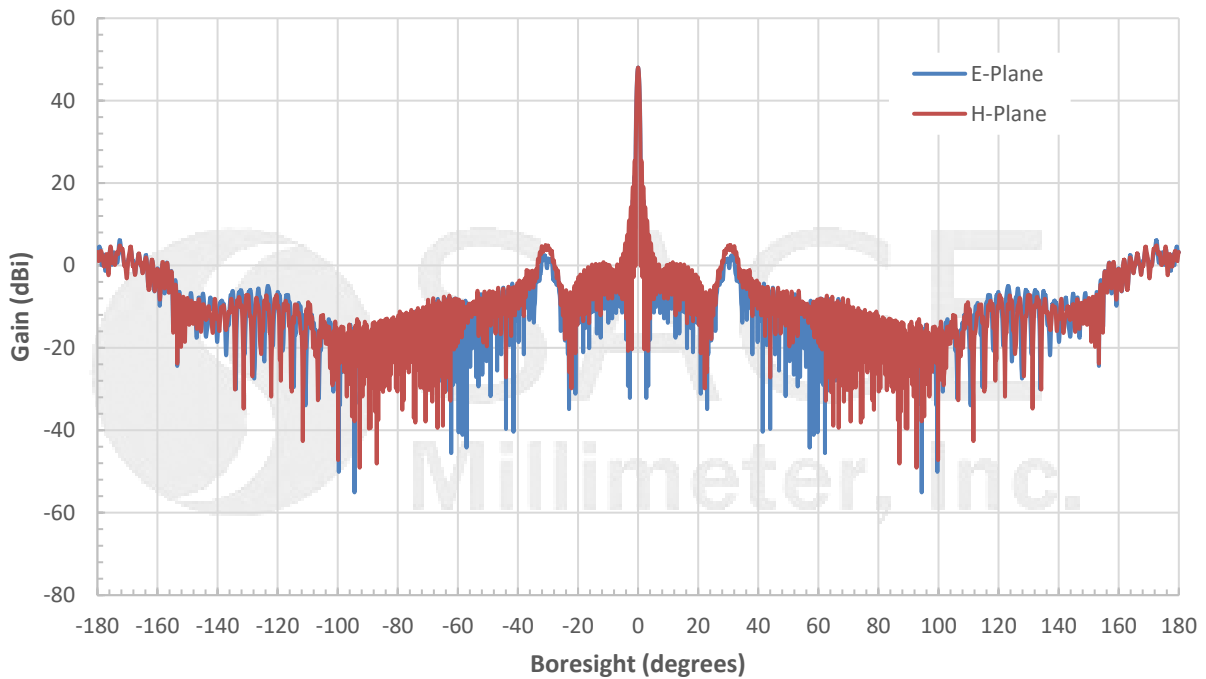

Simulated Antenna Patterns @ 94 GHz

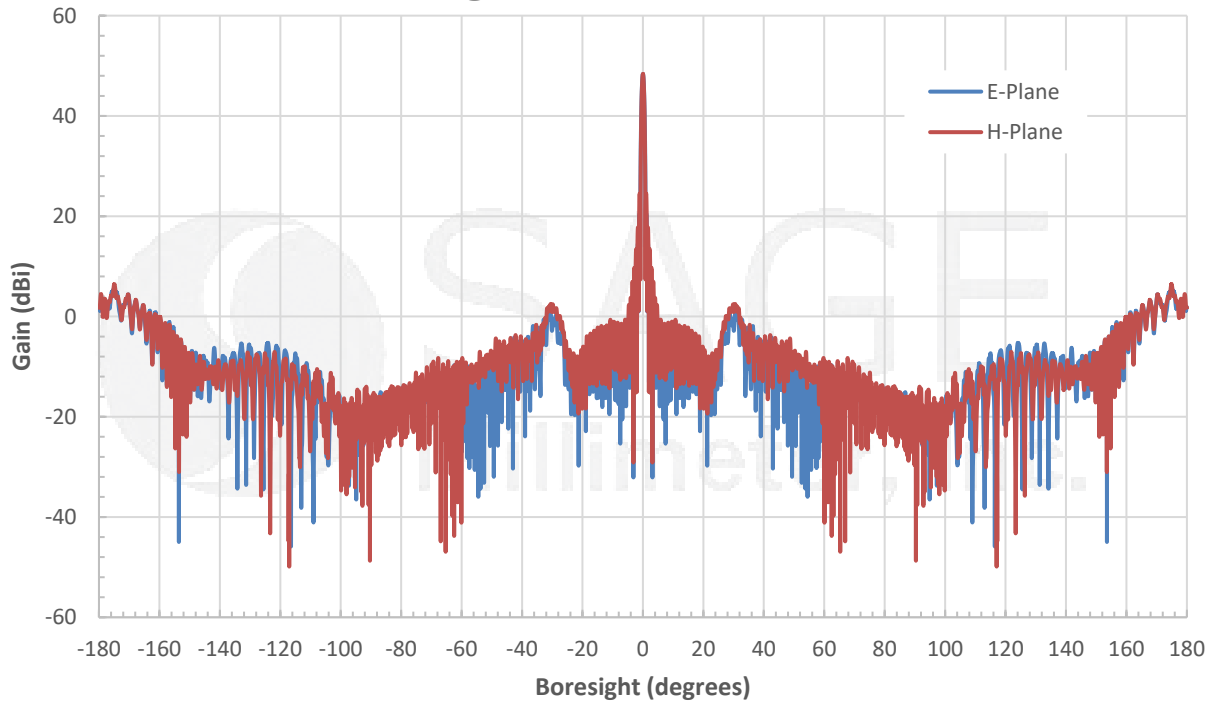



W Band Gaussian Optics Antenna

Simulated Antenna Patterns @ 100 GHz

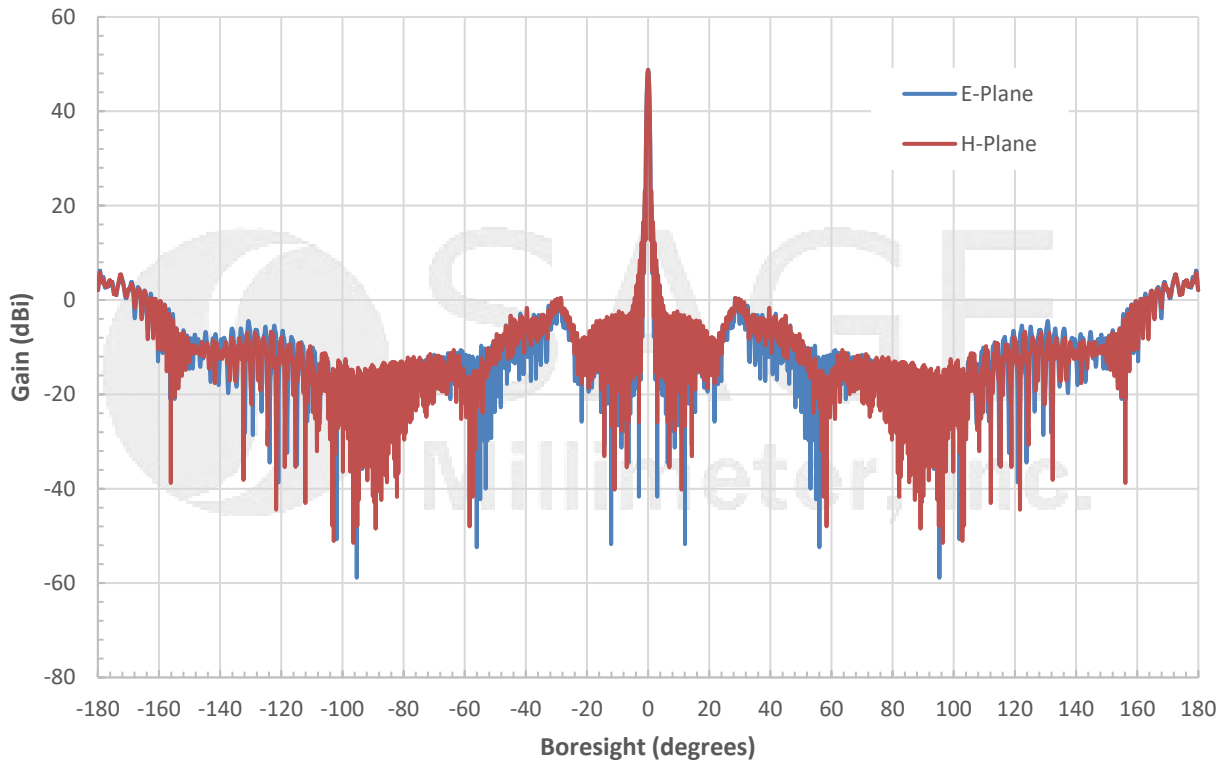

Simulated Gain vs. Frequency

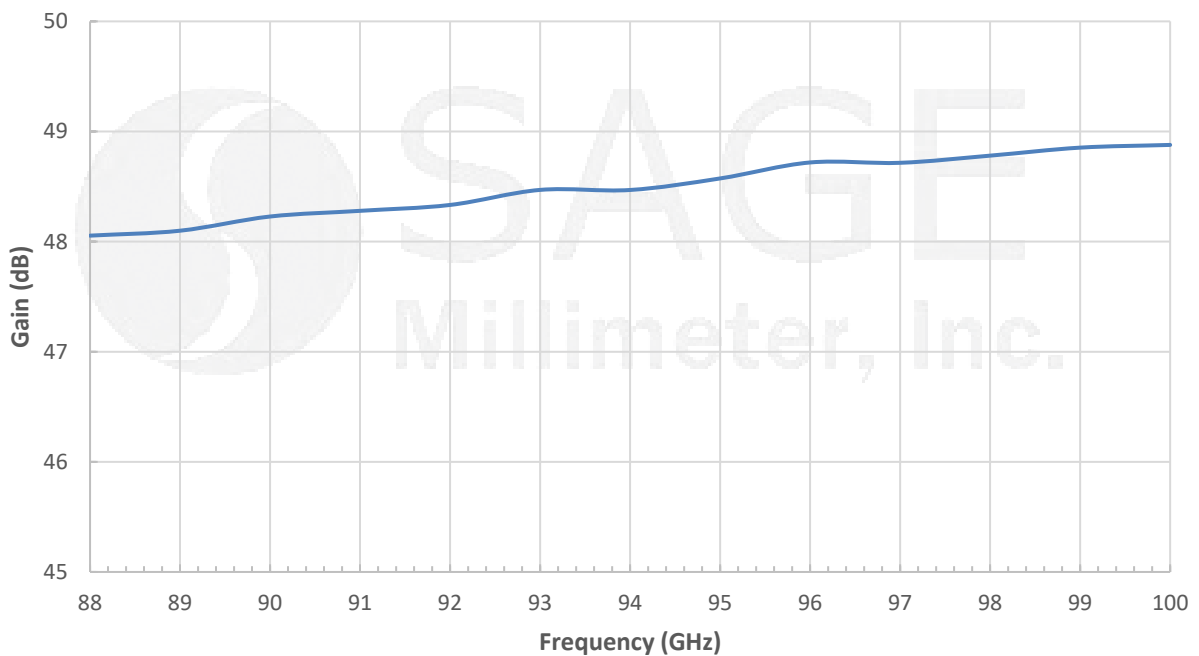



W Band Gaussian Optics Antenna

Simulated Return Loss vs. Frequency

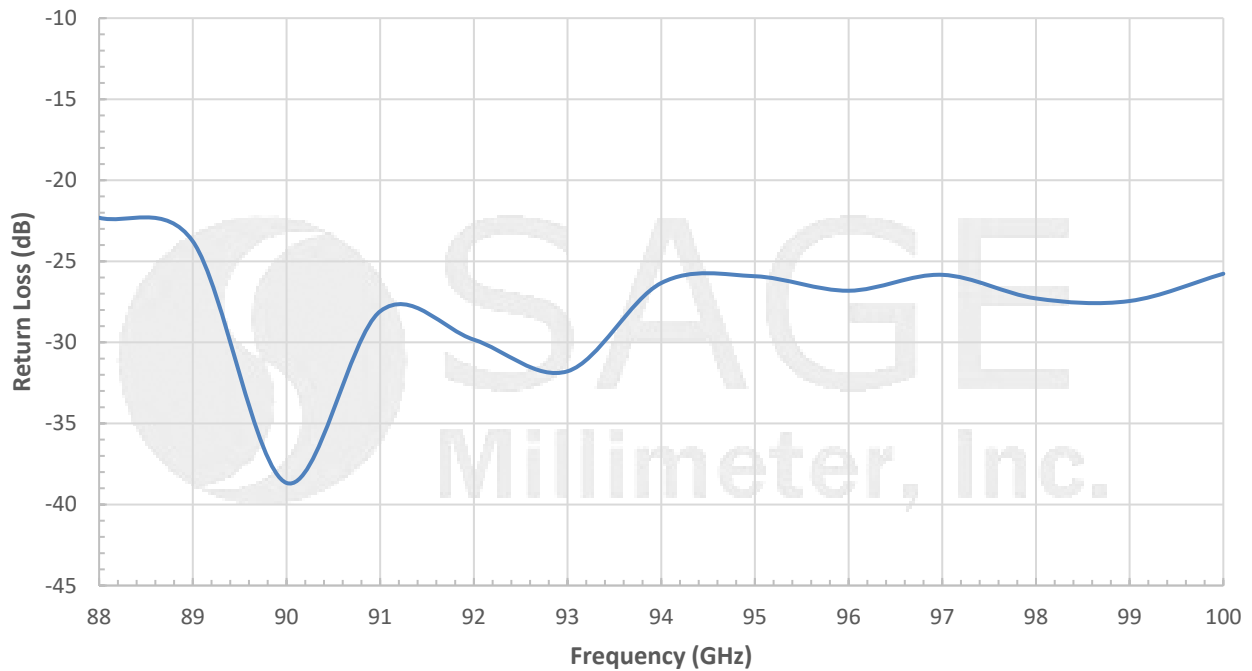

Mechanical Outline: (Unless otherwise specified, all dimensions are in inches)

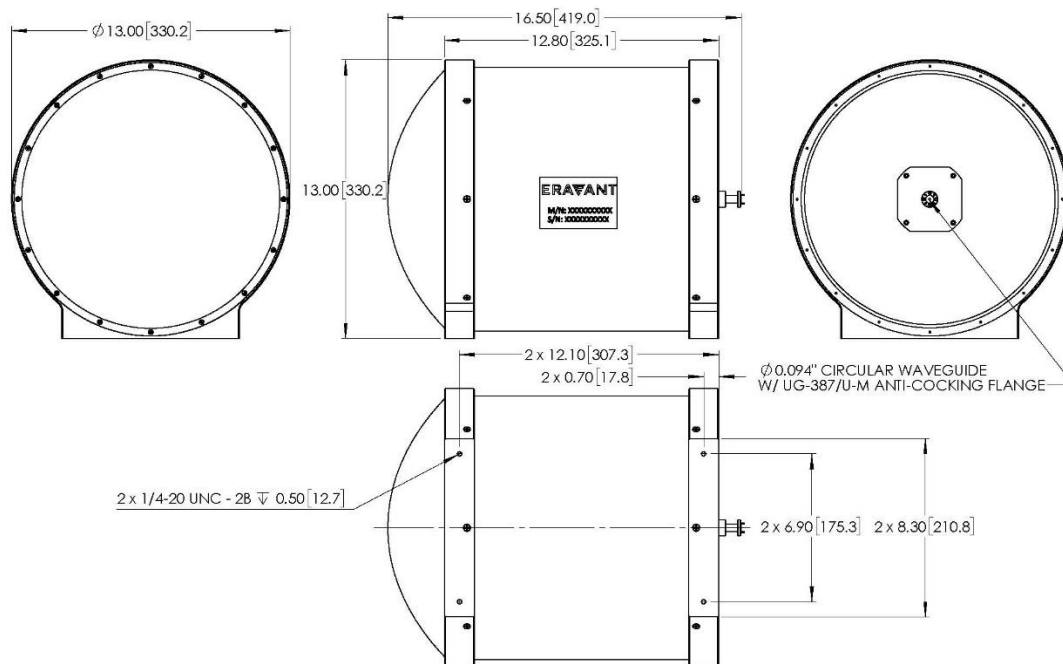

www.eravant.com | 501 Amapola Ave, Torrance, CA 90501
 Phone: 424-757-0168 | Fax: 424-757-0188 | Email: support@eravant.com



W Band Gaussian Optics Antenna

Note:

- Eravant reserves the right to change the information presented without notice.
- The operation frequency of the antenna can be extended to a wider range with small performance degradation at the edges of the band.

Caution:

- Foreign objects in the waveguide will affect the antenna performance and may damage the antenna.

