

SAC-2507-039-S2

WR-03 Conical Horn Antenna, 25 dBi Gain

SAC-2507-039-S2 is a WR-03 conical horn antenna that operates from 220 to 325 GHz. The antenna offers 25 dBi nominal gain and a typical half power beamwidth of 7.5 degrees on the E-plane and 8.5 degrees on the H-plane. The horn also offers typical sidelobes of -16 dB on the E-plane and -28 dB on the H-plane. The conical horn can support linear and circular polarization. The input of this antenna is a 0.039" diameter circular waveguide with UG-387/U-M Anti-Cocking Flange.



Electrical Specifications:

Parameter	Minimum	Typical	Maximum
Frequency	220 GHz		325 GHz
Gain		25 dBi	
3 dB Beamwidth, E-plane		7.5°	
3 dB Beamwidth, H-plane		8.5°	
Sidelobes, E-plane		-16 dB	
Sidelobes, H-plane		-28 dB	
Cross-polarization**		30 dB	
Return Loss		23 dB	
Specification Temperature		+25°C	
Operating Temperature	-45°C		+85°C

****Actual measured cross-polarization level shall be around 40dB TYP, 35 dB min,**

however, our testing service needs to be purchased to guarantee the level.

Contact us for more information.

Mechanical Specifications:

Item	Specification
Antenna Port	0.039" Diameter Circular Waveguide
Flange Type	UG-387/ U-M Anti-Cocking Flange
Material	Brass
Finish	Gold Plated
Weight	1 Oz
Outline	AC-C033-039-A

ECCN

EAR99

FEATURES

- Circular Waveguide Interface
- Precisely Machined and Gold Plated
- High Return Loss
- Linear and Circular Polarization

APPLICATIONS

- Antenna Ranges
- Feed Horns
- System Setups

SUPPLEMENTAL DETAILS



Simulated Antenna Patterns @ 220 GHz

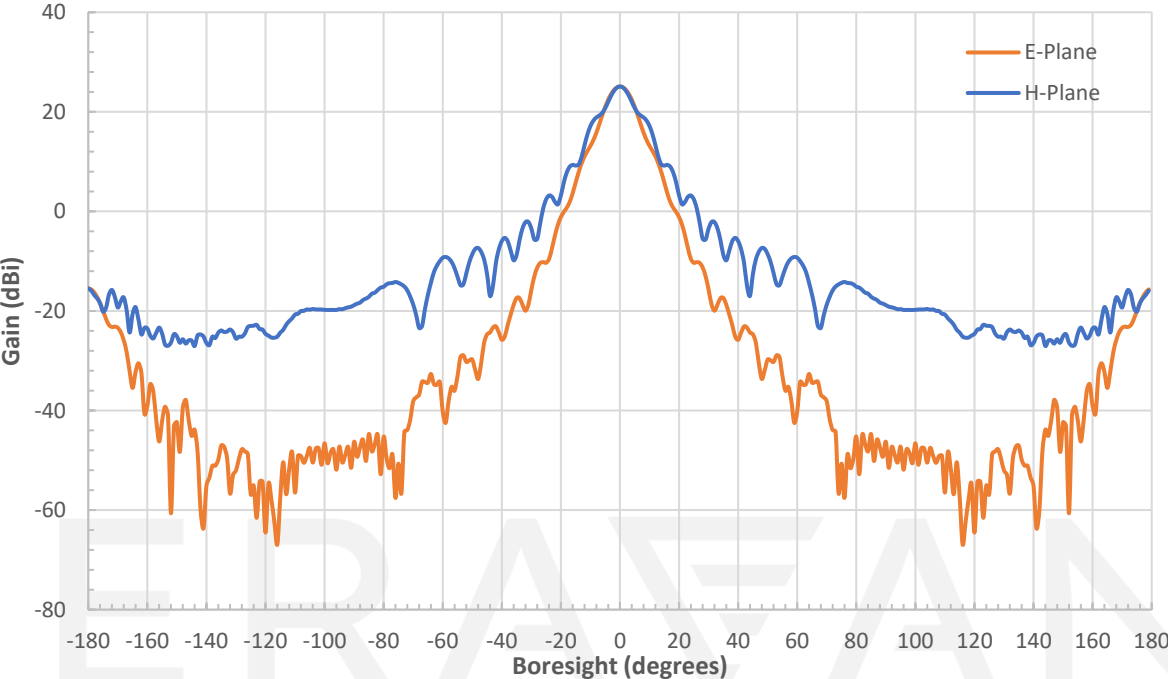

Simulated Antenna Patterns @ 272.5 GHz

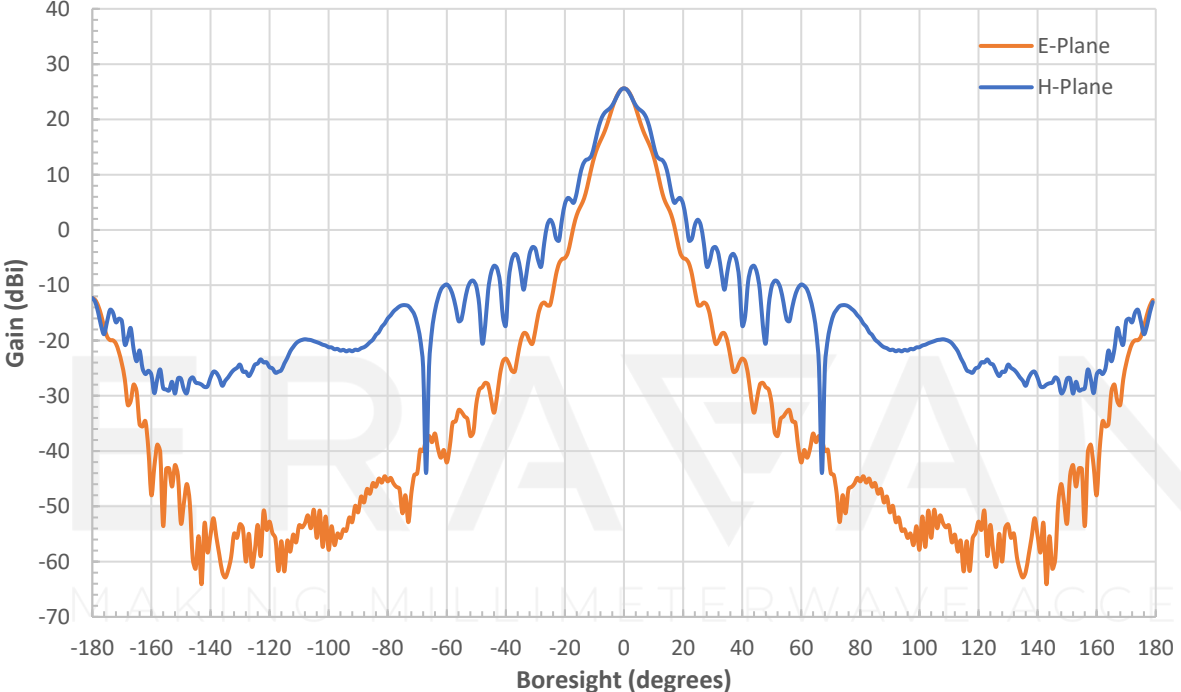

Simulated Antenna Patterns @ 325 GHz

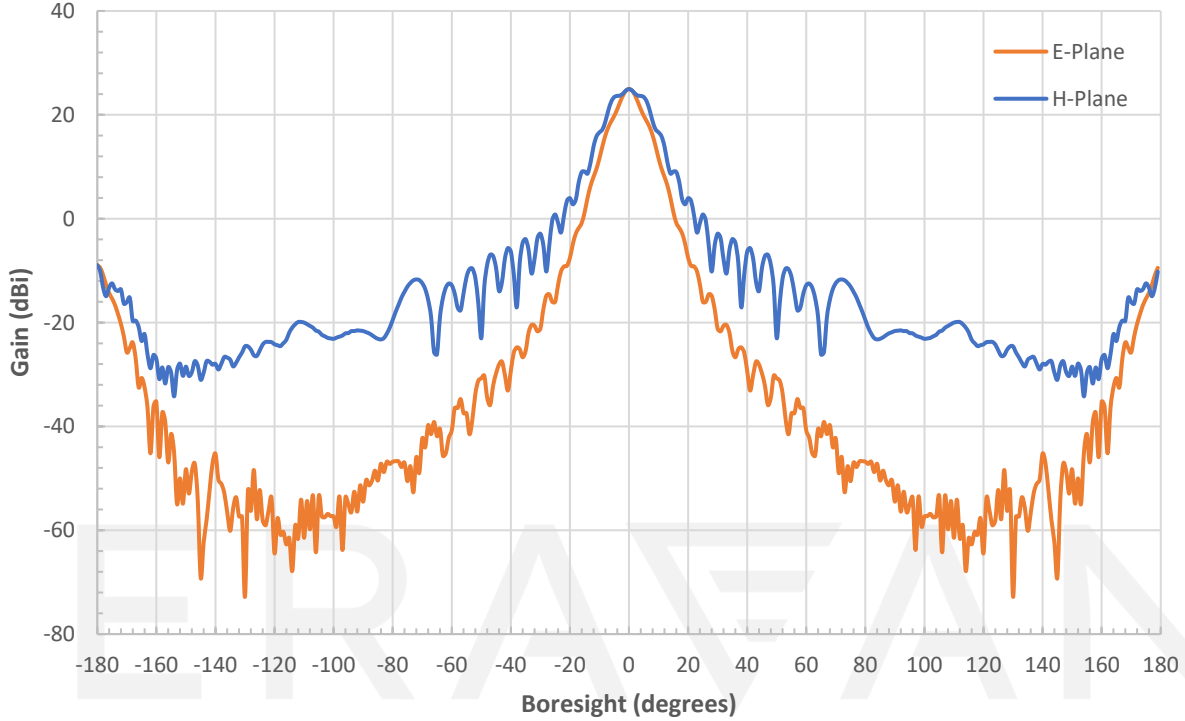

MAKING MILLIMETERWAVE ACCESSIBLE

Simulated Gain vs. Frequency

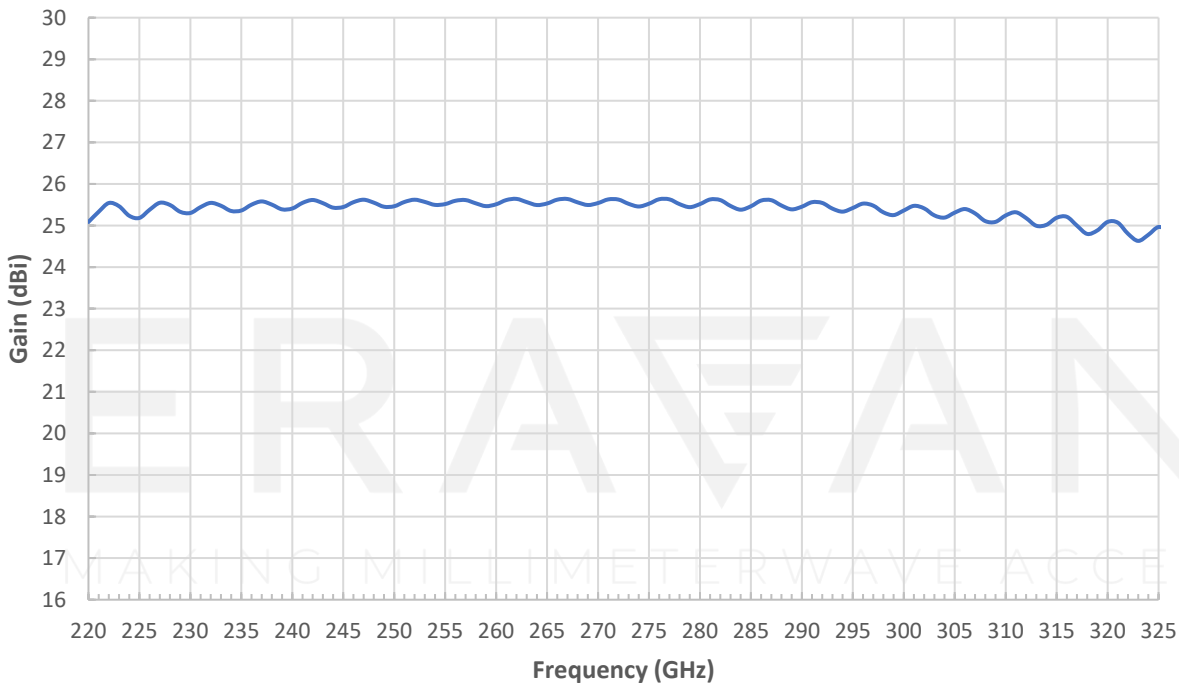

MAKING MILLIMETERWAVE ACCESSIBLE

SAC-2507-039-S2

Mechanical Outline: (Unless otherwise specified, all dimensions are in inches [millimeters])

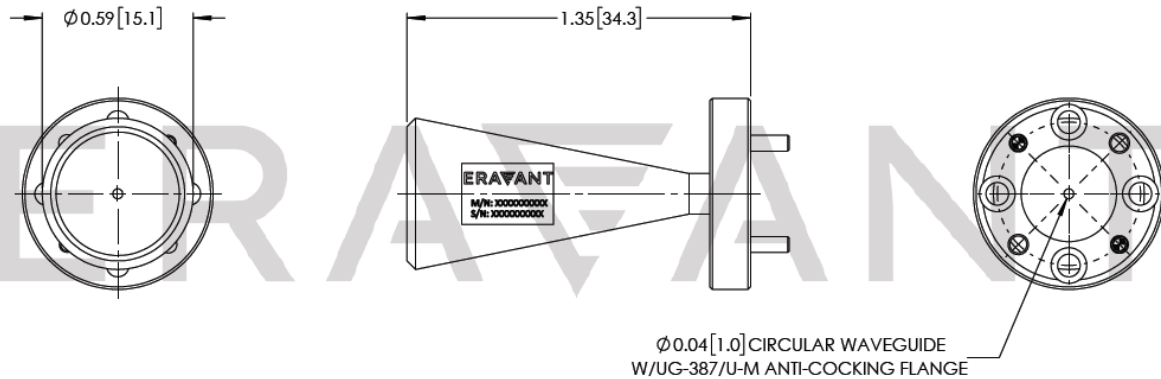

NOTE:

- This antenna is a mature product. The reasons for only providing simulated data can be found in the following [blog here](#).
- Eravant reserves the right to change the information presented without notice.

CAUTION:

- Any foreign objects in the waveguide will cause performance degradation and may damage the device.