



Ku Band, Conical Horn Antenna

Description:

Model SAC-2309-594-M2 is a conical horn antenna that operates from 13.4 GHz to 18 GHz. The antenna offers 23 dBi nominal gain, 9 degrees half power beamwidth and -15 dB typical sidelobe level at center frequency. The conical horn antenna can support linear and circular polarization. The input of this antenna is a 0.594" diameter circular waveguide with UG419/U flange. The antenna features a built-in mounting bracket that is compatible with a standard camera tripod.



Features:

- Circular Waveguide Interface
- Mounting Bracket
- High Return Loss

Applications:

- Antenna Ranges
- Feed Horns
- System Setups

Electrical Specifications:

Parameter	Minimum	Typical	Maximum
Frequency *	13.4 GHz		18.0 GHz
Gain		23 dBi	
3 dB Beamwidth		9°	
Sidelobe Level		-15 dB	
Return Loss		21 dB	
Specification Temperature		+25 °C	
Operating Temperature	-45 °C		+85 °C

*The operating frequency can be stretched to cover 12 to 18 GHz operation.

Mechanical Specifications:

Parameter	Connector
Antenna Port	0.594" Diameter Circular Waveguide
Flange Type	UG419/U Flange
Material	Aluminum
Inner Finish	Silver Plated
Outer Finish	Black Paint
Weight	11.6 Oz
Size	9.0" (L) X 4.5" (Ø)
Outline	AC-C6-594-M





Ku Band, Conical Horn Antenna

Simulated Antenna Patterns @ 13 GHz

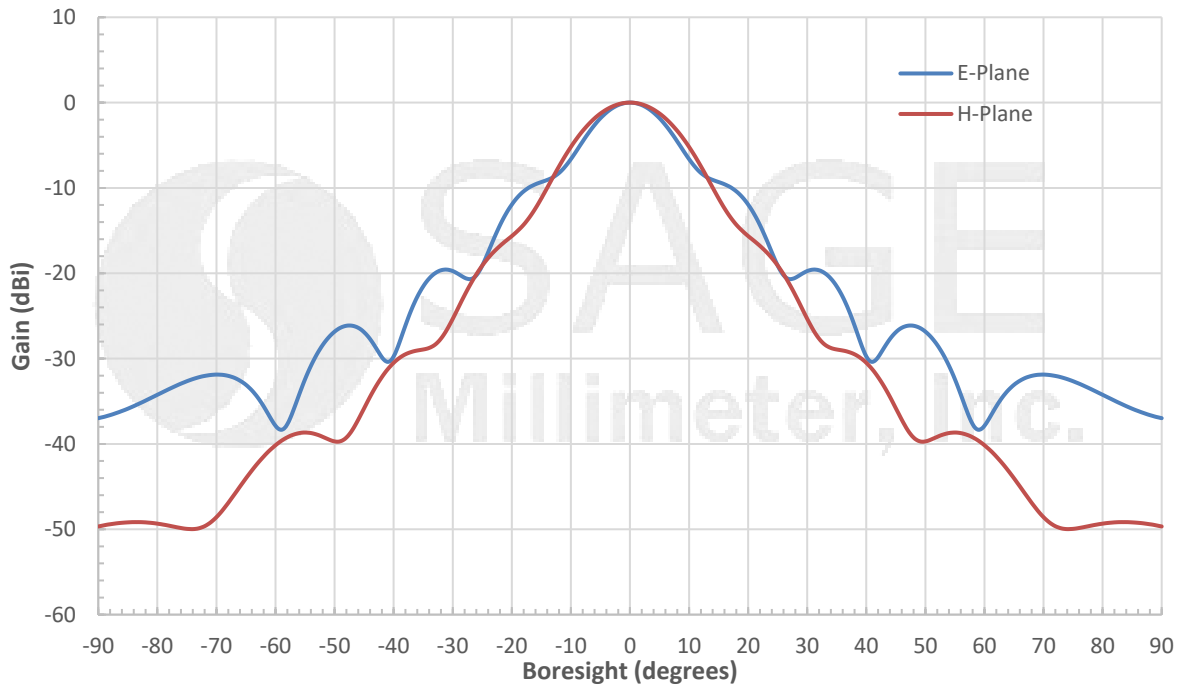

Simulated Antenna Patterns @ 15.5 GHz

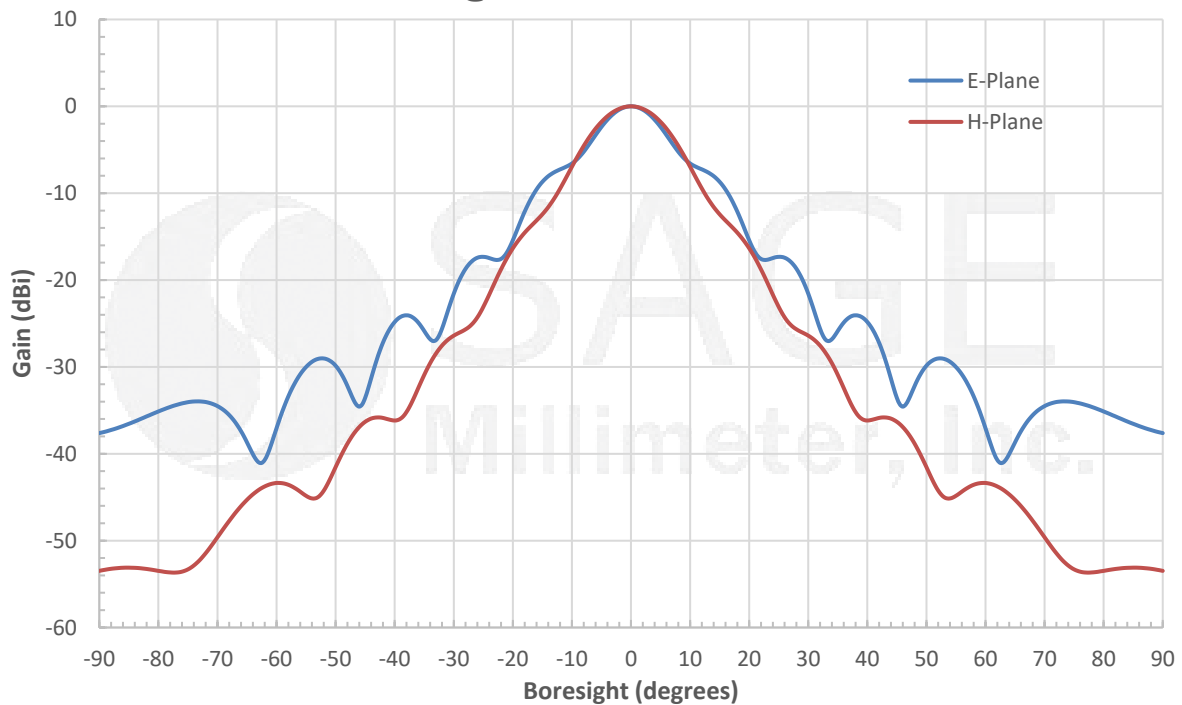



Ku Band, Conical Horn Antenna

Simulated Antenna Patterns @ 18 GHz

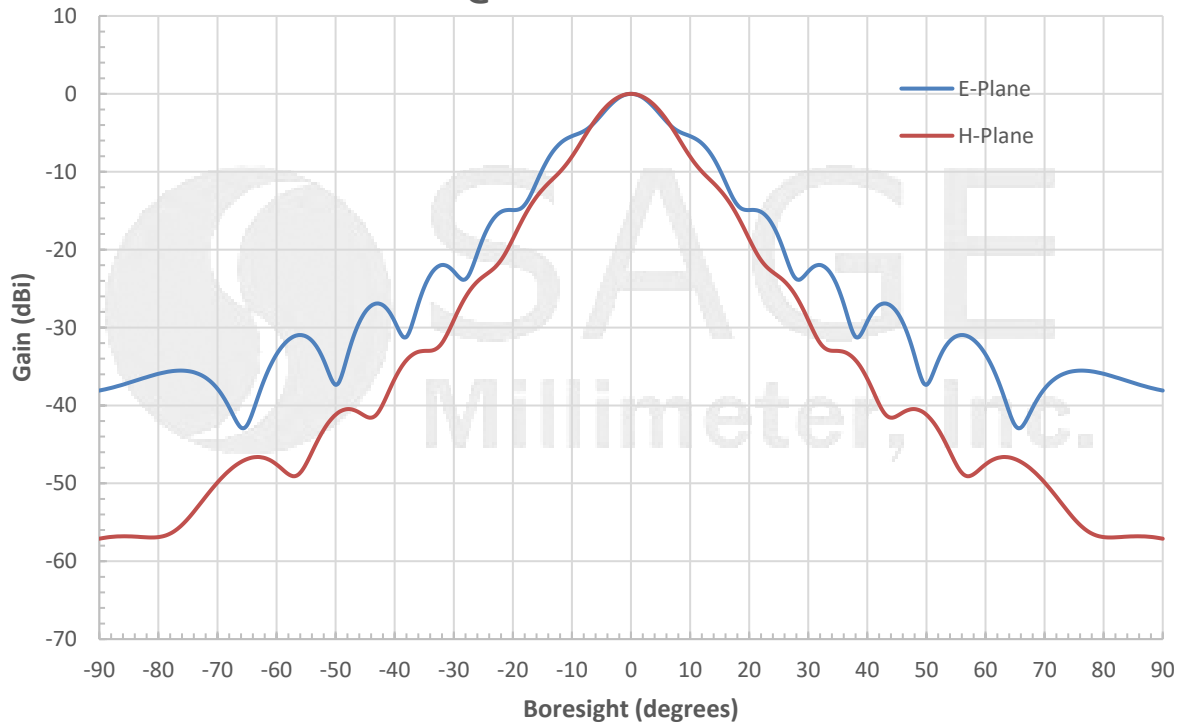

Simulated Gain vs. Frequency

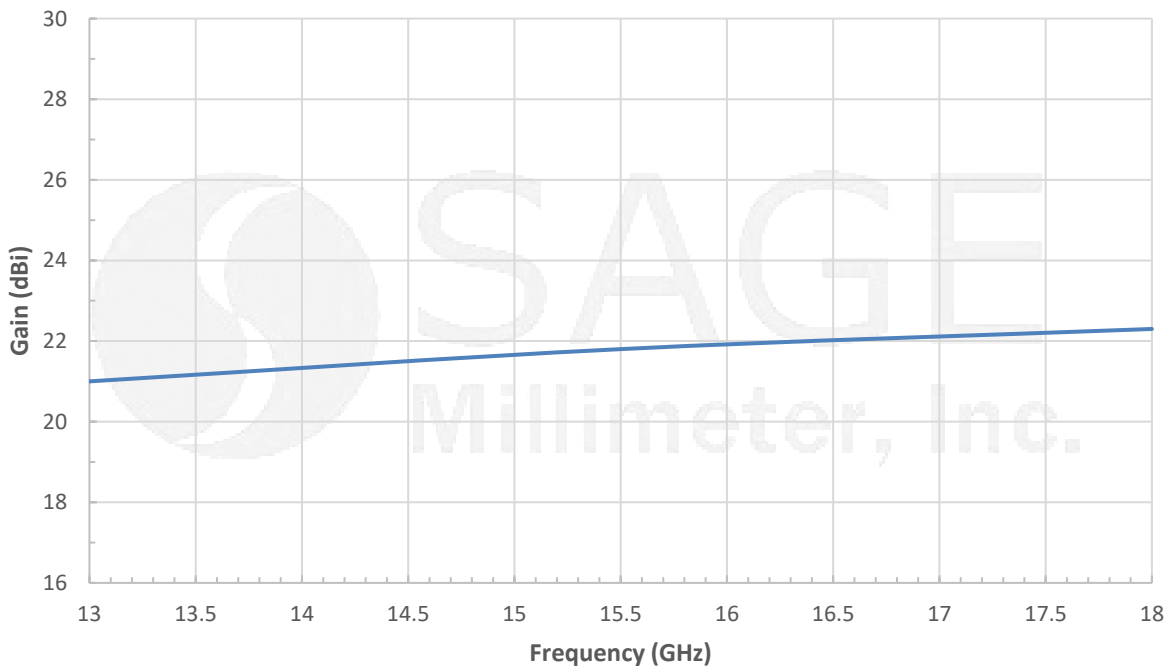



Ku Band, Conical Horn Antenna

Typical Measured Return Loss vs. Frequency

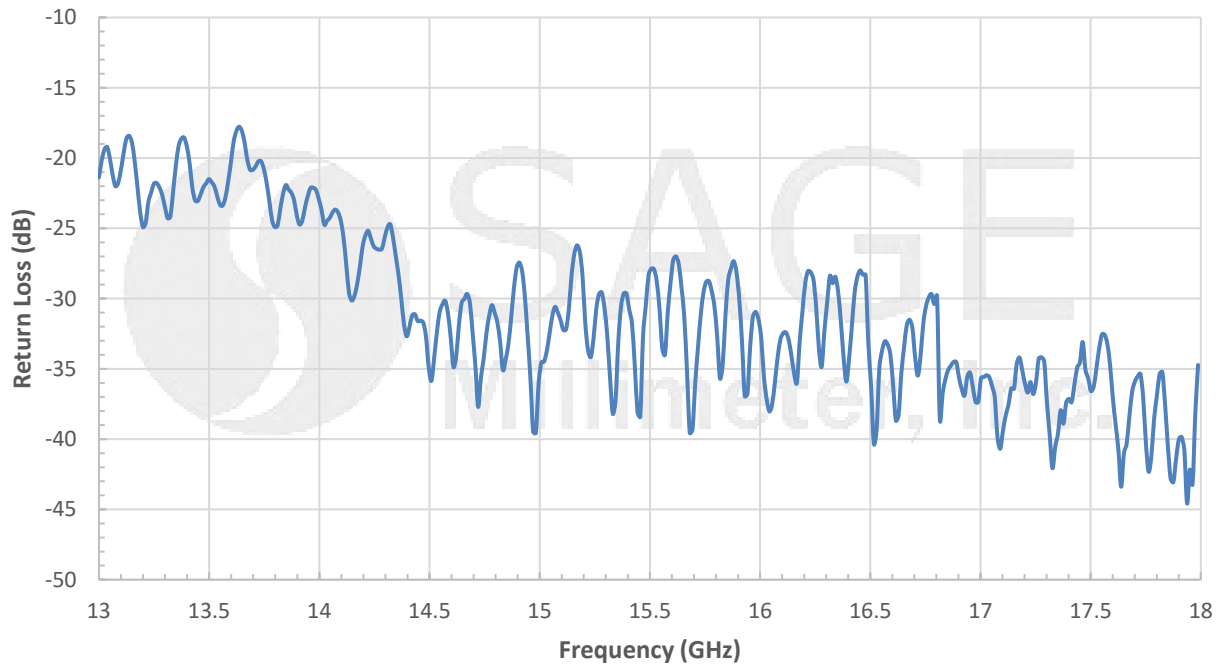

Mechanical Outline: (Unless otherwise specified, all dimensions are in inches[millimeters])

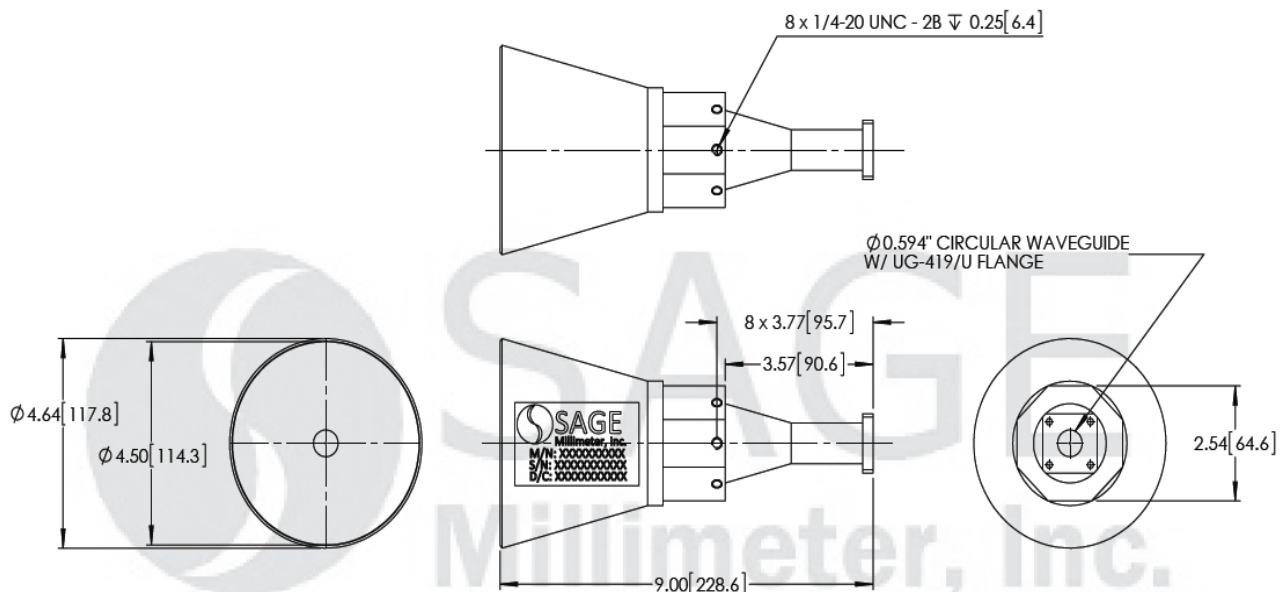



Ku Band, Conical Horn Antenna

Note:

- This antenna is a mature product. The reasons for only providing simulated data can be found in the following blog [here](#).
- All testing was performed under 25°C case temperature.
- Eravant reserves the right to change the information presented without notice.

Caution:

- Any foreign objects in the horn antenna will cause performance degradation and possible device damage.

