

SAC-1533-141-S2

V Band Conical Horn Antenna, 15 dBi Gain

SAC-1533-141-S2 is a V-band conical horn antenna that operates from 58 to 68 GHz. The antenna offers 15 dBi nominal gain and a typical half power beamwidth of 30 degrees on the E-plane and 36 degrees on the H-plane. The horn also offers typical sidelobes of -16 dB on the E-plane and -28 dB on the H-plane. The conical horn can support linear and circular polarization. The input of this antenna is a 0.141" diameter circular waveguide with UG-385/U-M flange.



Electrical Specifications:

Parameter	Minimum	Typical	Maximum
Frequency Range*	58 GHz		68 GHz
Gain		15 dBi	
3 dB Beamwidth, E-Plane		30°	
3 dB Beamwidth, H-Plane		36°	
Sidelobes, E-plane		-16 dB	
Sidelobes, H-plane		-28 dB	
Return Loss		23 dB	
Specification Temperature		+25°C	
Operating Temperature	-40°C		+85°C

*Note: Can operate from 54 to 75 GHz if the dominant mode is maintained.

Mechanical Specifications:

Item	Specification
Antenna Port	0.141" Diameter Circular Waveguide
Flange Type	UG-385/U-M Flange
Material	Brass
Finish	Gold Plated
Weight	0.6 Oz
Size	0.70" (L) X 0.47" (Ø)
Outline	AC-CV15-141

ECCN

EAR99

FEATURES

- Circular Waveguide Interface
- Precisely Machined and Gold Plated
- High Return Loss
- Linear and Circular Polarization

APPLICATIONS

- Antenna Ranges
- Feed Horns
- System Setups

SUPPLEMENTAL DETAILS



Simulated Antenna Patterns @ 58 GHz

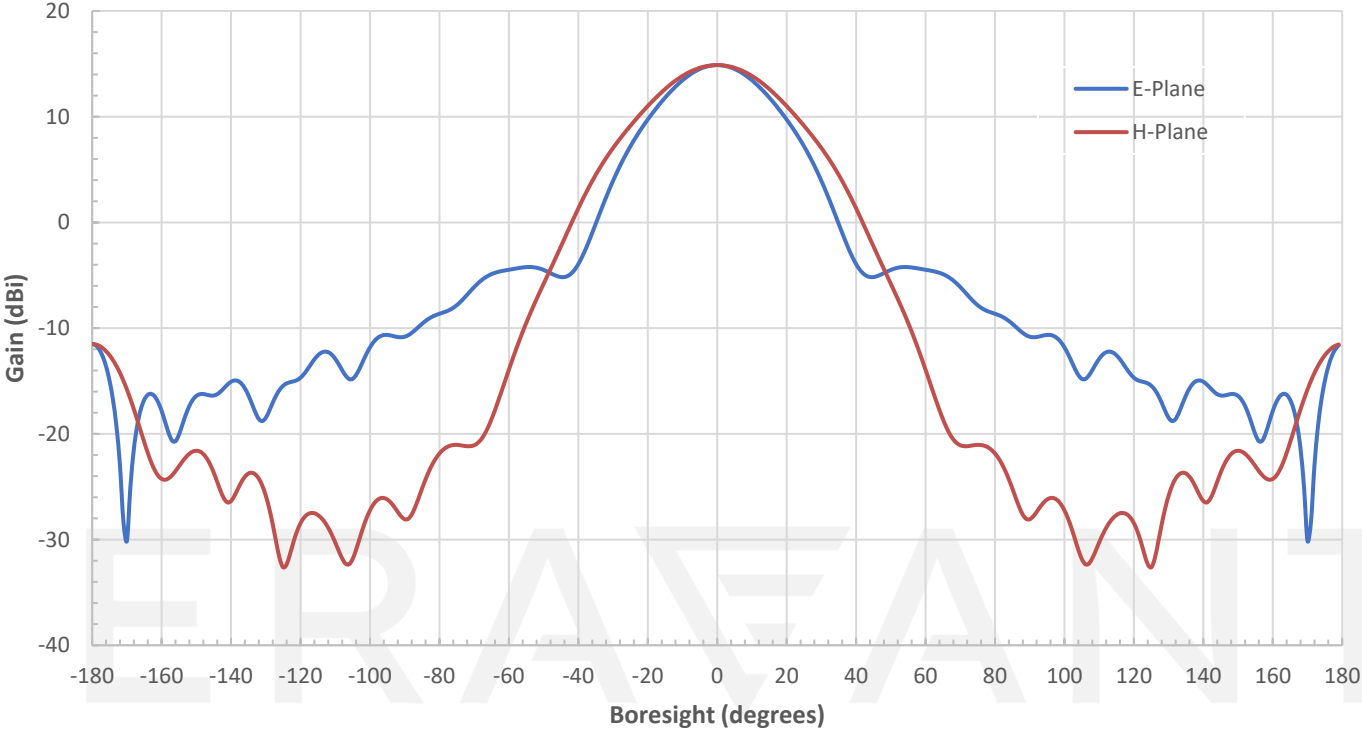

Simulated Antenna Patterns @ 63 GHz

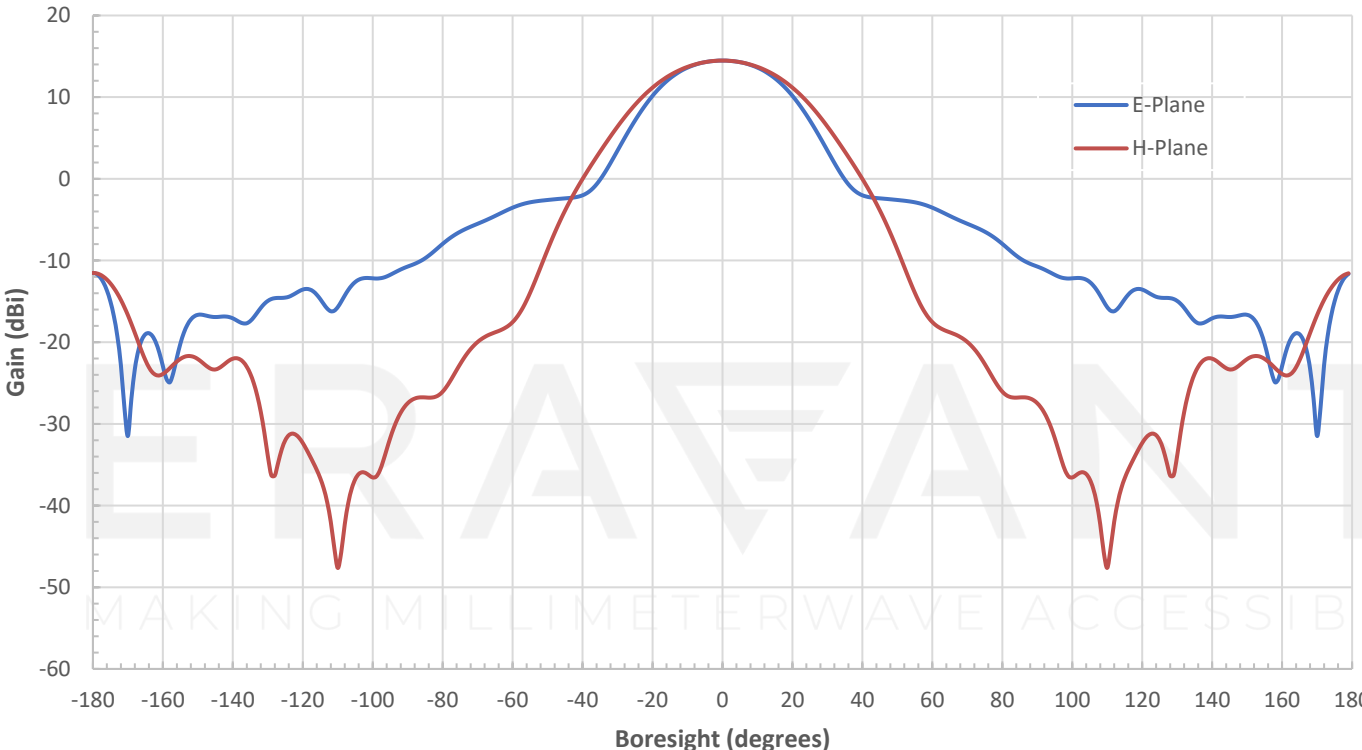

Simulated Antenna Patterns @ 68 GHz

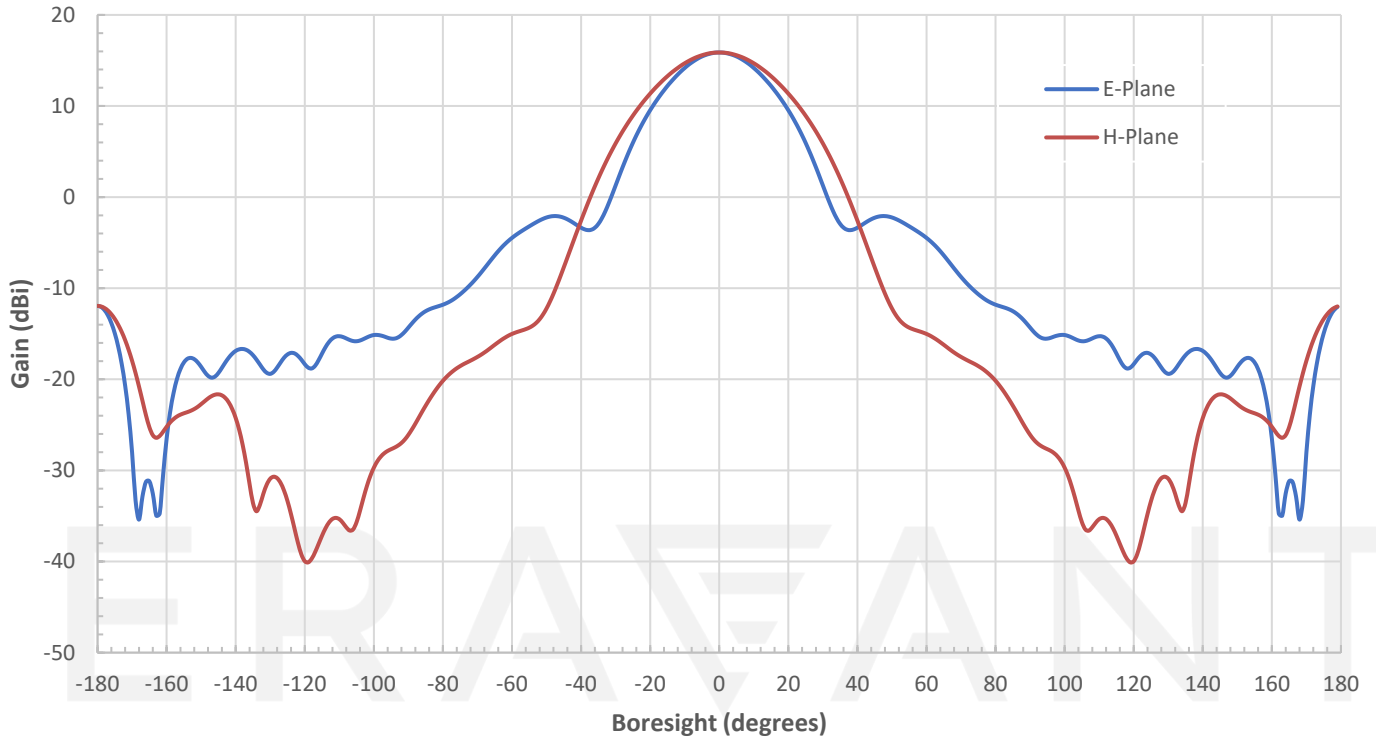

Simulated Return Loss vs. Frequency

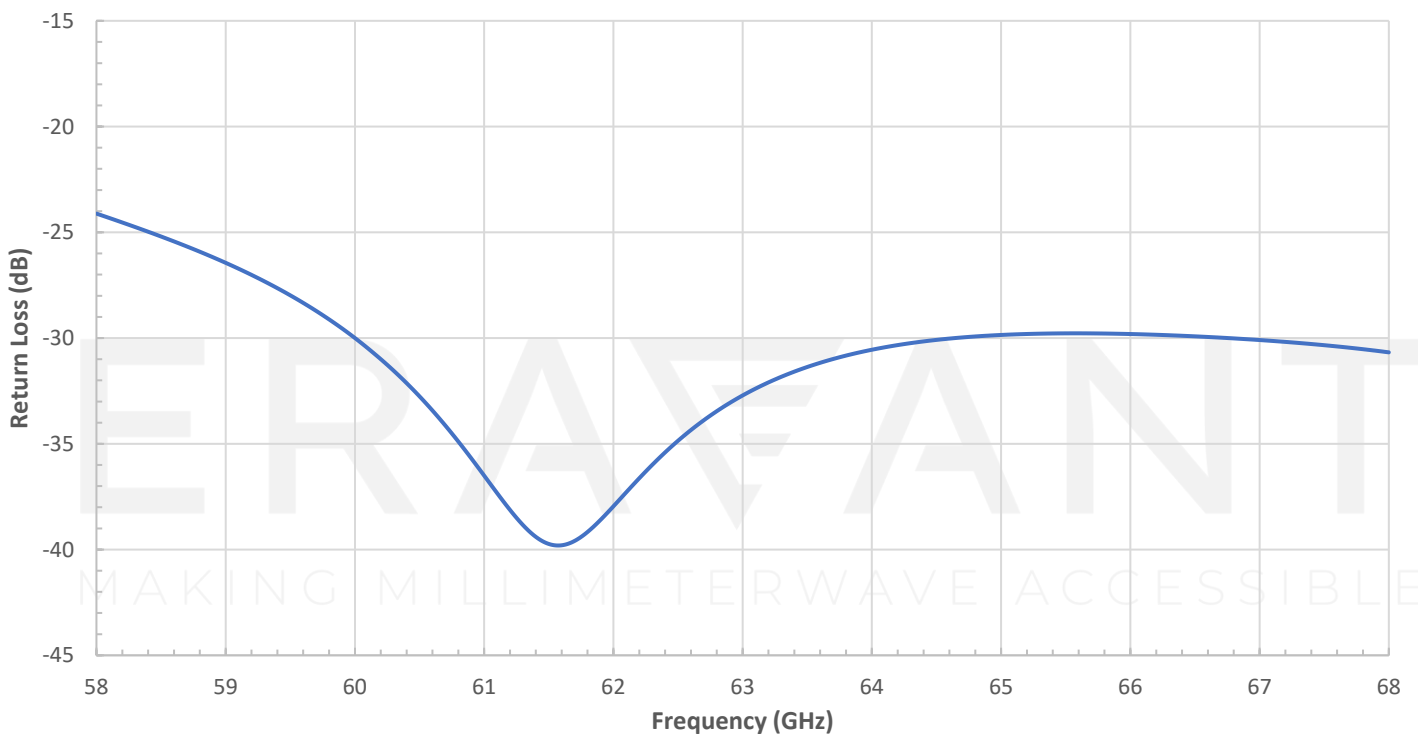

SAC-1533-141-S2

Simulated Gain vs. Frequency

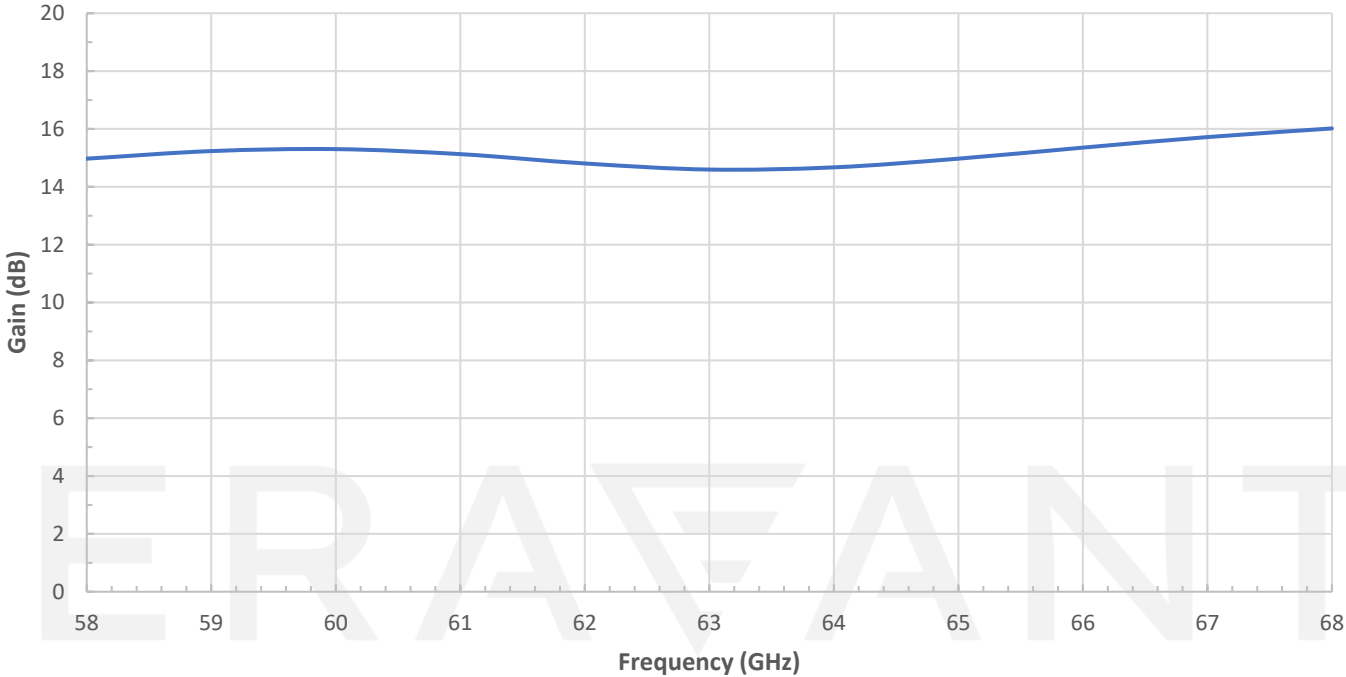

MAKING MILLIMETERWAVE ACCESSIBLE

Mechanical Outline: Unless otherwise specified, all dimensions are in inches [millimeters]

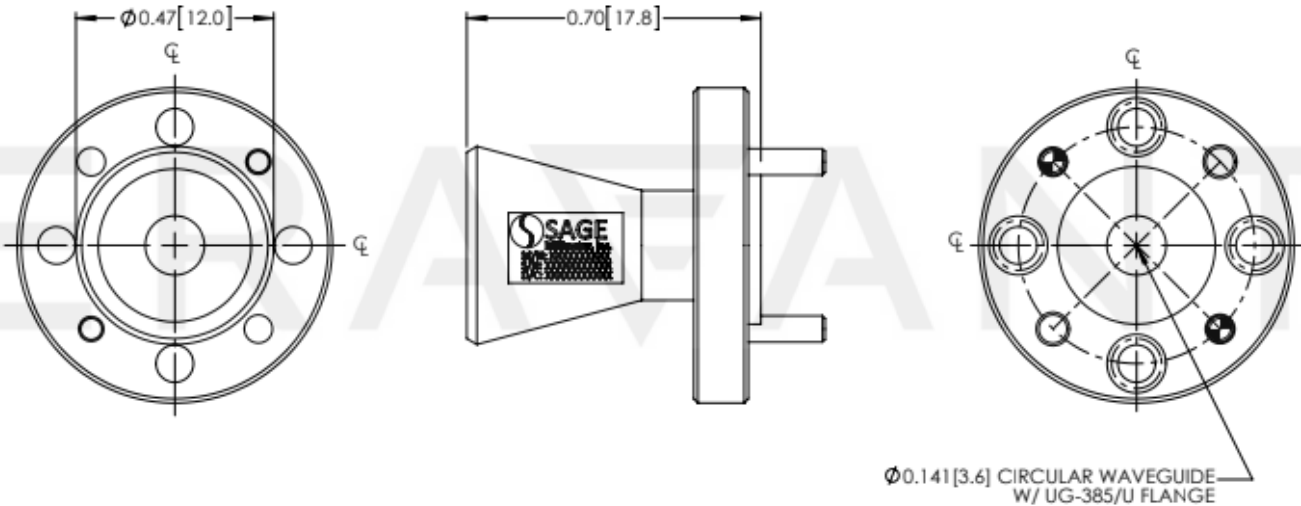

NOTE:

- This antenna is a mature product. The reasons for only providing simulated data can be found in the following blog [here](#).
- Eravant reserves the right to change the information presented without notice.

CAUTION:

- If a waveguide is present, any foreign objects in the waveguide will cause performance degradation and may damage or destroy the unit.
- Any foreign objects in the antenna will cause performance degradation and possible device damage.

ERAVANT
MAKING MILLIMETERWAVE ACCESSIBLE

ERAVANT
MAKING MILLIMETERWAVE ACCESSIBLE