

## SAC-1553-12-S2

### E Band Conical Horn Antenna, 15 dBi Gain, WR-12 Waveguide

**SAC-1553-12-S2** is an E-band conical horn antenna with a WR-12 rectangular waveguide interface that operates from 68 to 77 GHz. The antenna offers 15 dBi nominal gain and a typical half power beamwidth of 30 degrees on the E-plane and 36 degrees on the H-plane. The horn also offers typical sidelobes of -16 dB on the E-plane and -28 dB on the H-plane. The conical horn can support linear polarization. The RF connector of this antenna is a WR-12 waveguide with UG-387/U anti-cocking flange.



#### Electrical Specifications:

Parameter	Minimum	Typical	Maximum
Frequency*	68 GHz		77 GHz
Gain		15 dBi	
3 dB Beamwidth, E-plane		30°	
3 dB Beamwidth, H-plane		36°	
Sidelobes, E-plane		-16 dB	
Sidelobes, H-plane		-28 dB	
Return Loss		23 dB	
Specification Temperature		+25°C	
Operating Temperature	-40°C		+85°C

\*Note: Can operate from 63 to 90 GHz if the dominant mode is maintained.

#### Mechanical Specifications:

Item	Specification
Antenna Port	WR-12 Waveguide
Flange Type	UG-387/U Anti-Cocking Flange
Material	Brass
Finish	Gold Plated
Weight	0.5 Oz
Size	0.70" (L) X 0.42" (Ø)
Outline	AC-RE15-125-A

#### FEATURES

- Rectangular Waveguide Interface
- Precisely Machined and Gold Plated
- High Return Loss
- Linear Polarization

#### APPLICATIONS

- Antenna Ranges
- Feed Horns
- System Setups

MAKING MILLIMETERWAVE ACCESSIBLE



### Simulated Antenna Patterns @ 68 GHz

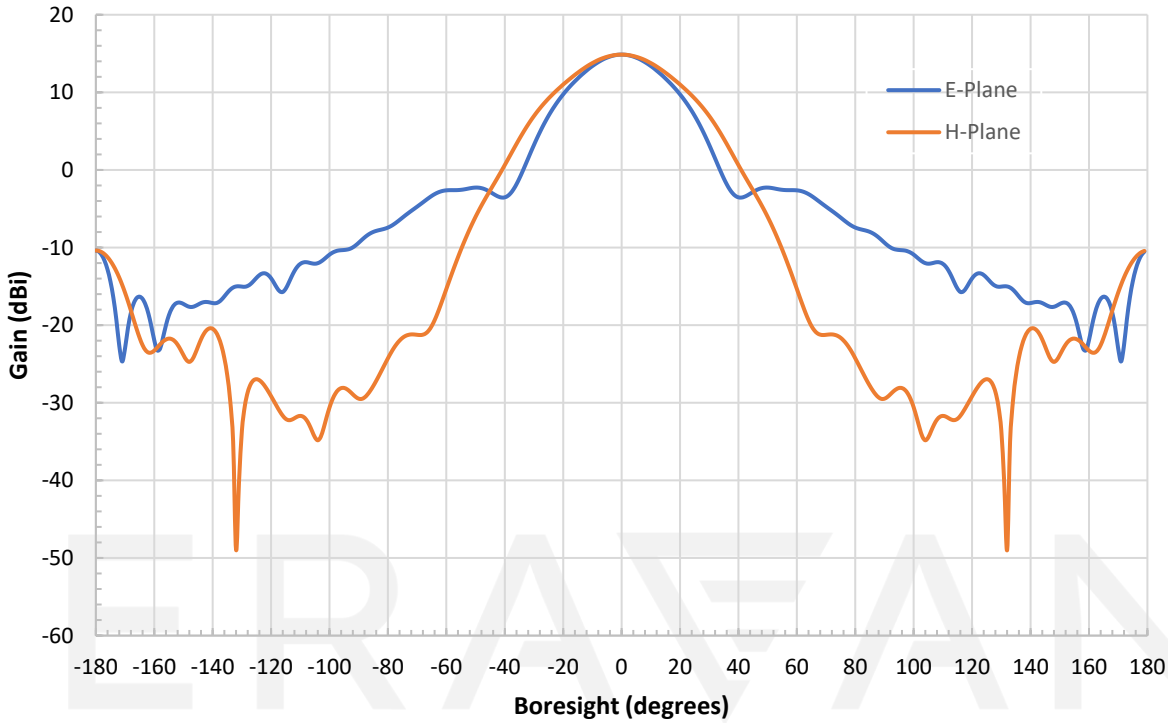

### Simulated Antenna Patterns @ 72 GHz

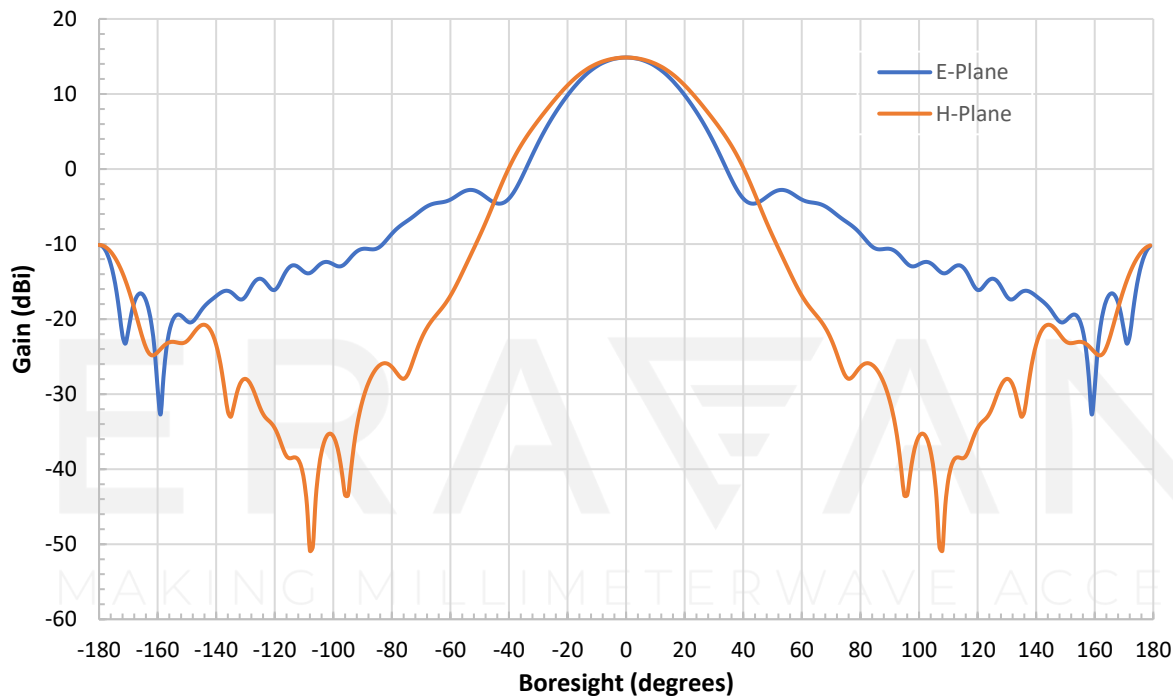

### Simulated Antenna Patterns @ 77 GHz

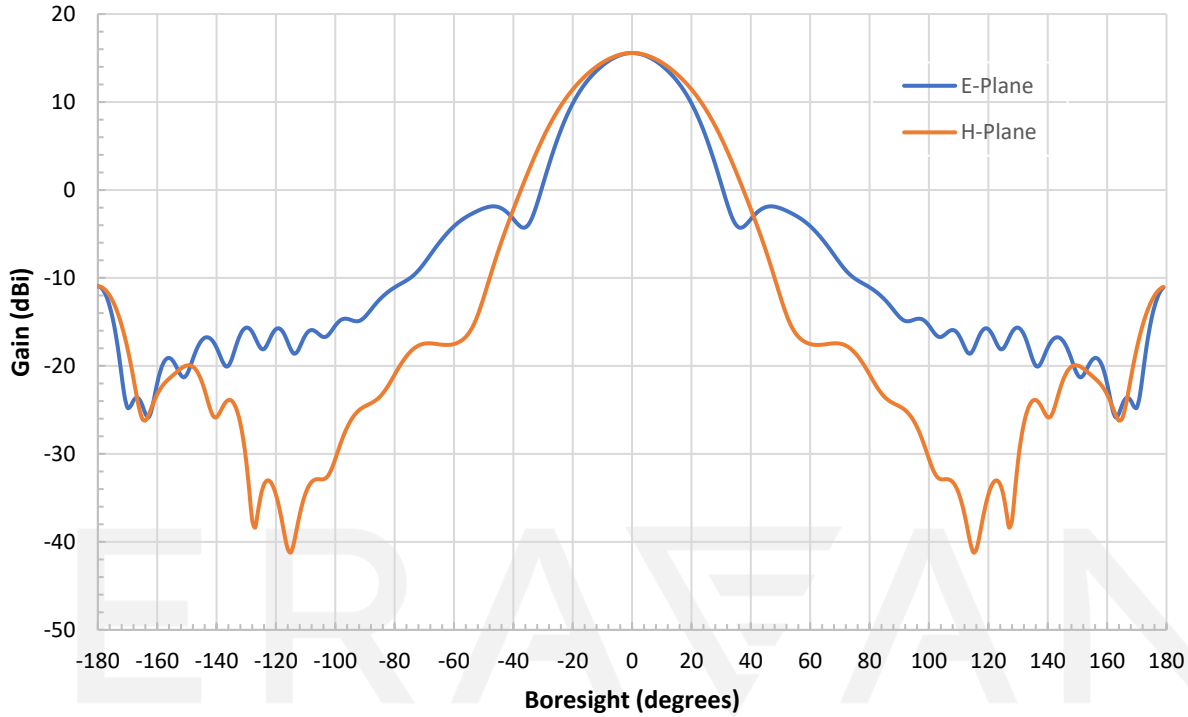

### Simulated Return Loss vs. Frequency

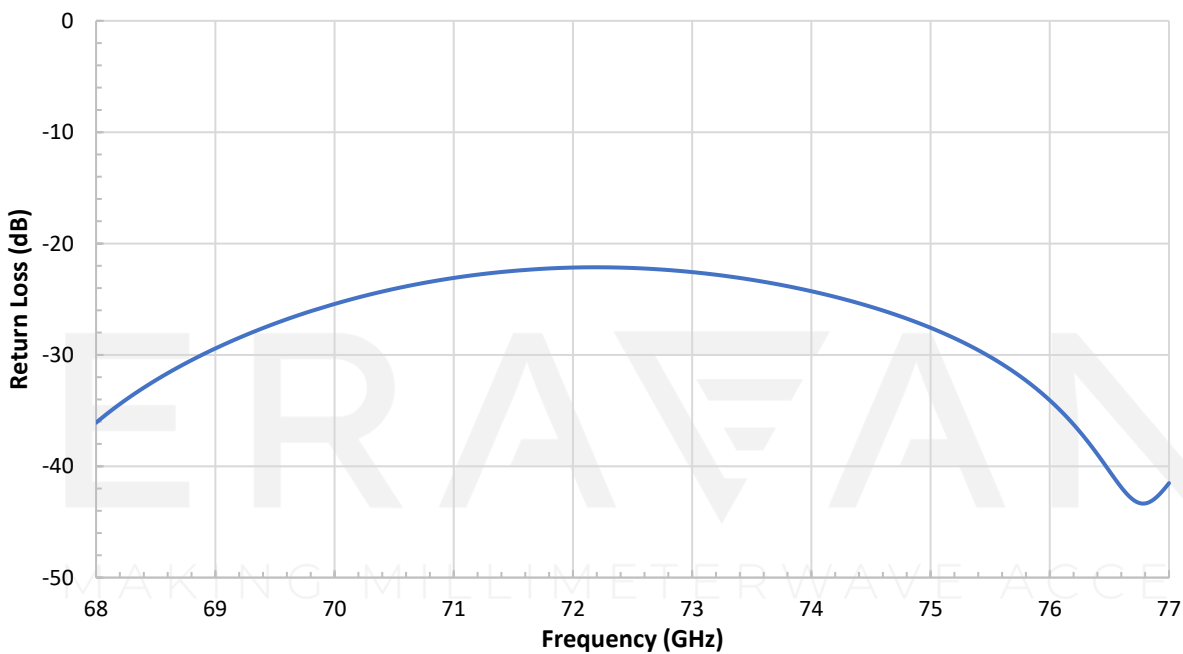

### Simulated Gain vs. Frequency

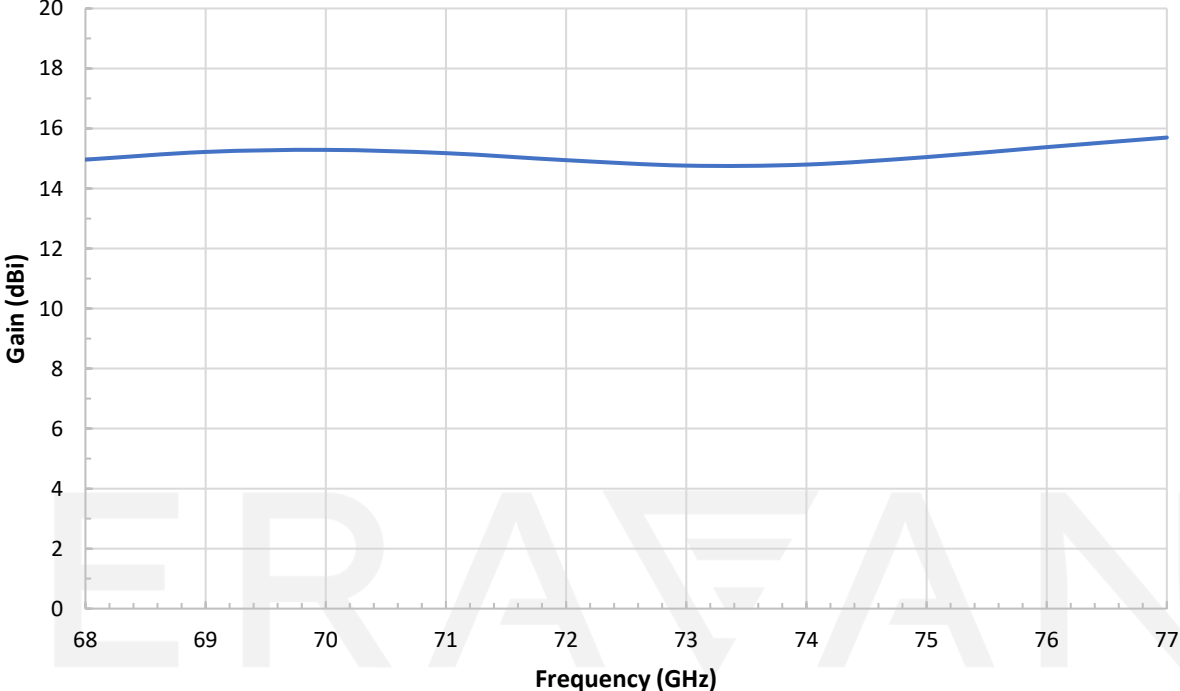

MAKING MILLIMETERWAVE ACCESSIBLE

### Mechanical Outline: (Unless otherwise specified, all dimensions are in inches [millimeters])

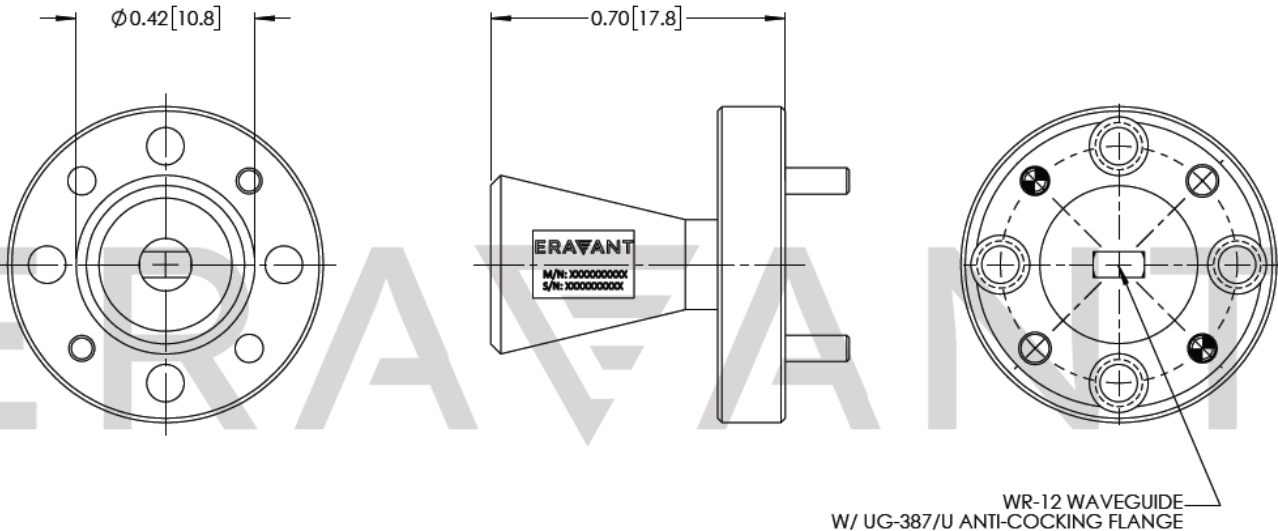

---

**NOTE:**

- This antenna is a mature product. The reasons for only providing simulated data can be found in the following blog here.
- Eravant reserves the right to change the information presented without notice.

**CAUTION:**

- Any foreign objects in the waveguide will cause performance degradation and may damage the device.

ERAVANT  
MAKING MILLIMETERWAVE ACCESSIBLE

ERAVANT  
MAKING MILLIMETERWAVE ACCESSIBLE