

SAC-1533-10-S2

W Band Conical Horn Antenna, 15 dBi Gain, WR-10 Waveguide

SAC-1533-10-S2 is a W-band conical horn antenna with a WR-10 rectangular waveguide interface that operates from 87 to 100 GHz. The antenna offers 15 dB nominal gain and a typical half power beamwidth of 30 degrees on the E-plane and 36 degrees on the H-plane. The horn also offers typical sidelobes of -16 dB on the E-plane and -28 dB on the H-plane. The conical horn can support linear polarization. The RF connector of this antenna is a WR-10 waveguide with UG-387/U-M flange.



Electrical Specifications:

Parameter	Minimum	Typical	Maximum
Frequency*	87 GHz		100 GHz
Gain		15 dB	
3 dB Beamwidth, E-plane		30°	
3 dB Beamwidth, H-plane		36°	
Sidelobes, E-plane		-16 dB	
Sidelobes, H-plane		-28 dB	
Return Loss		23 dB	
Specification Temperature		+25°C	
Operating Temperature	-40°C		+85°C

*Note: Can operate from 80 to 110 GHz if the dominant mode is maintained.

Mechanical Specifications:

Item	Specification
Antenna Port	WR-10 Waveguide
Flange Type	UG-387/U-M Flange
Material	Brass
Finish	Gold Plated
Weight	0.5 Oz
Size	0.55" (L) X 0.35"(Ø)
Outline	AC-RW15-094

ECCN

EAR99

FEATURES

- Circular Waveguide Interface
- Precisely Machined and Gold Plated
- High Return Loss
- Linear Polarization

APPLICATIONS

- Antenna Ranges
- Feed Horns
- System Setups

SUPPLEMENTAL DETAILS



Simulated Antenna Patterns @ 87 GHz

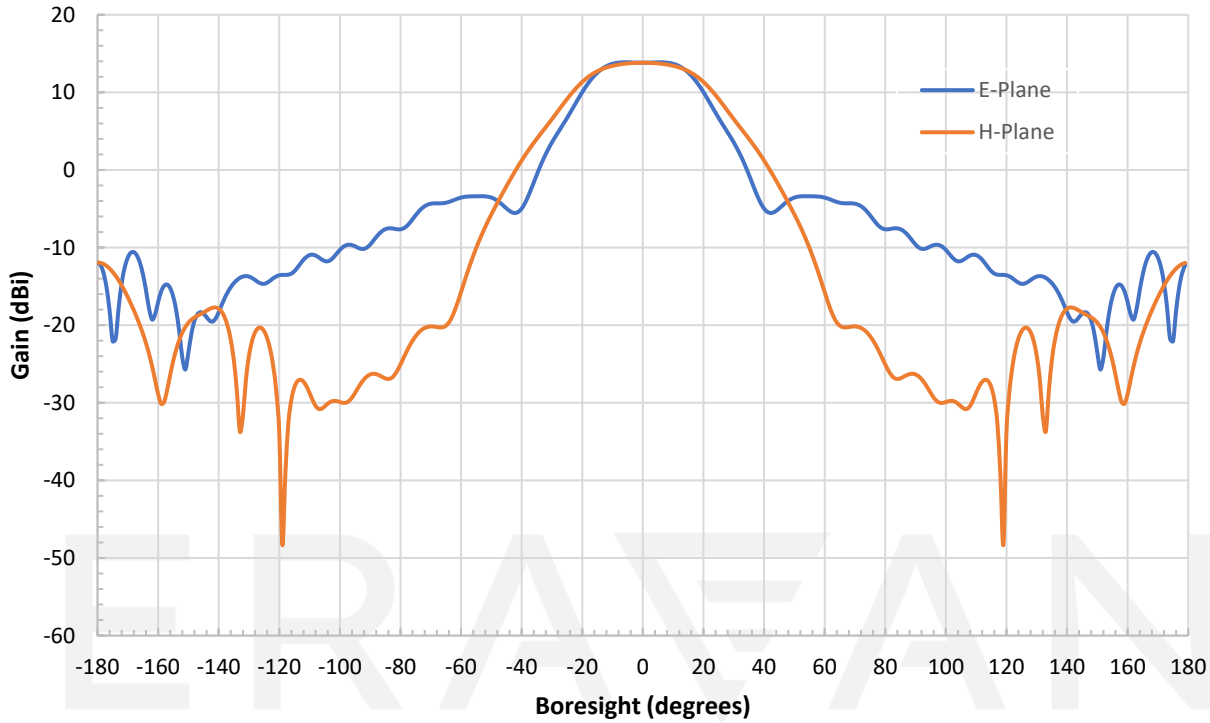

Simulated Antenna Patterns @ 93 GHz

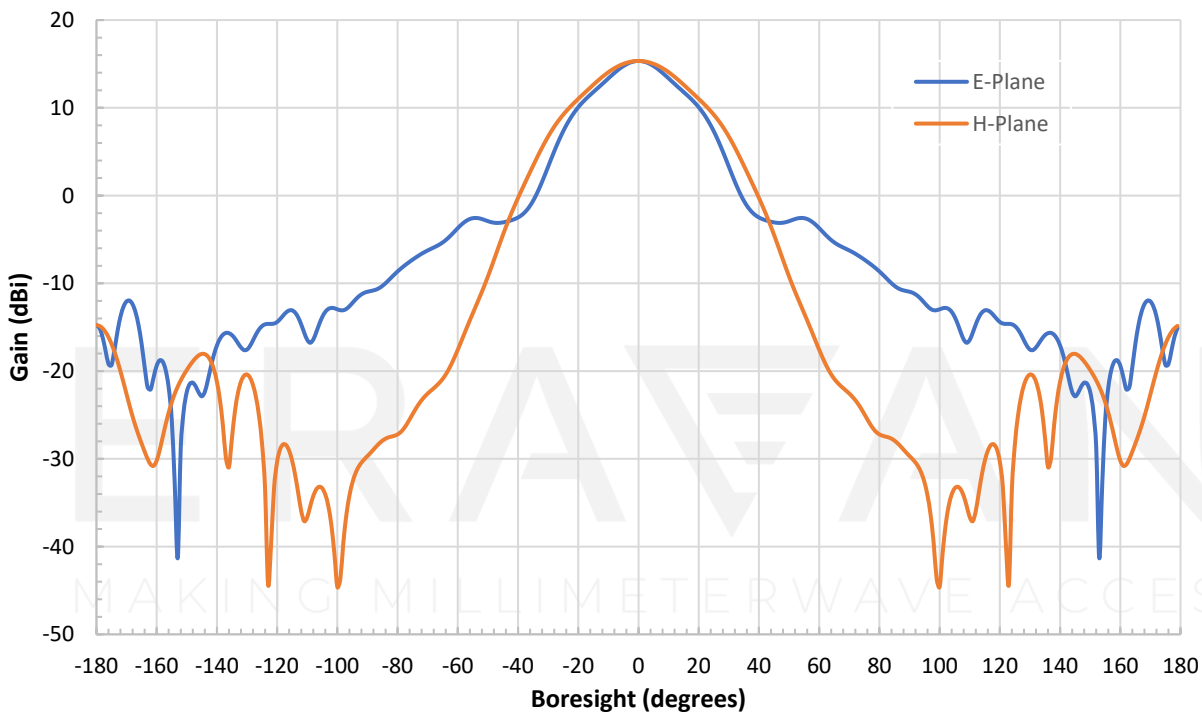

Simulated Antenna Patterns @ 100 GHz

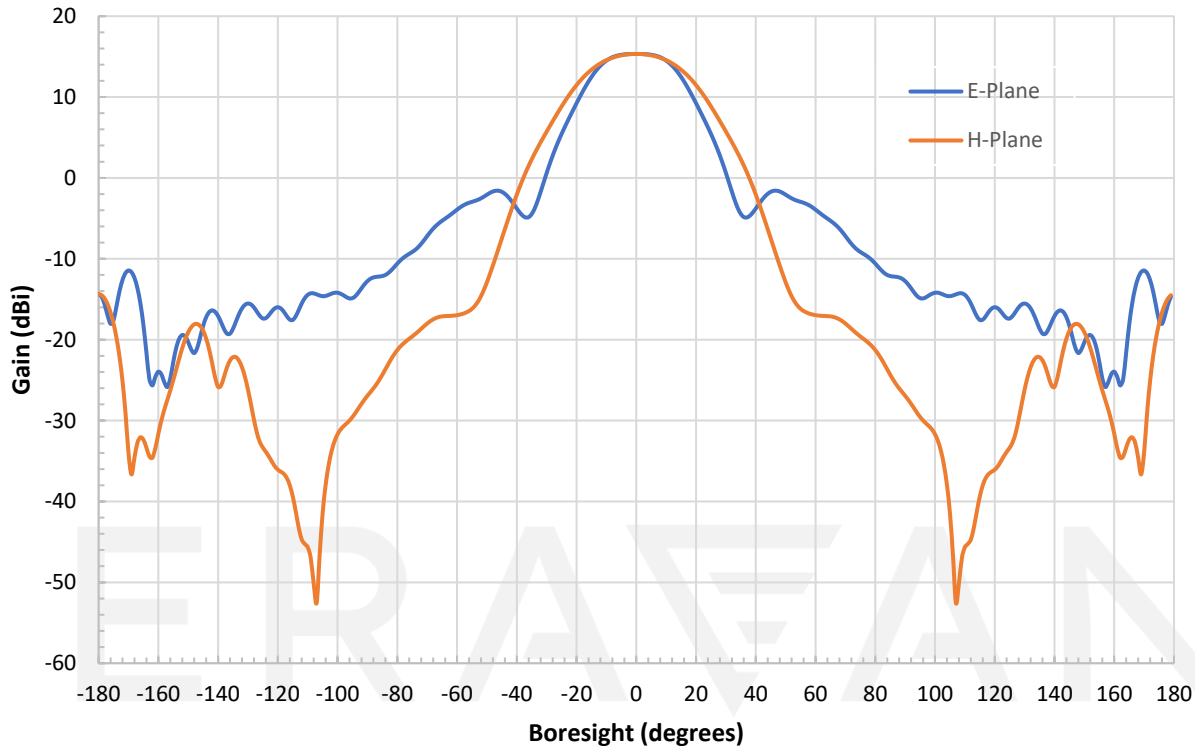

Simulated Return Loss vs. Frequency

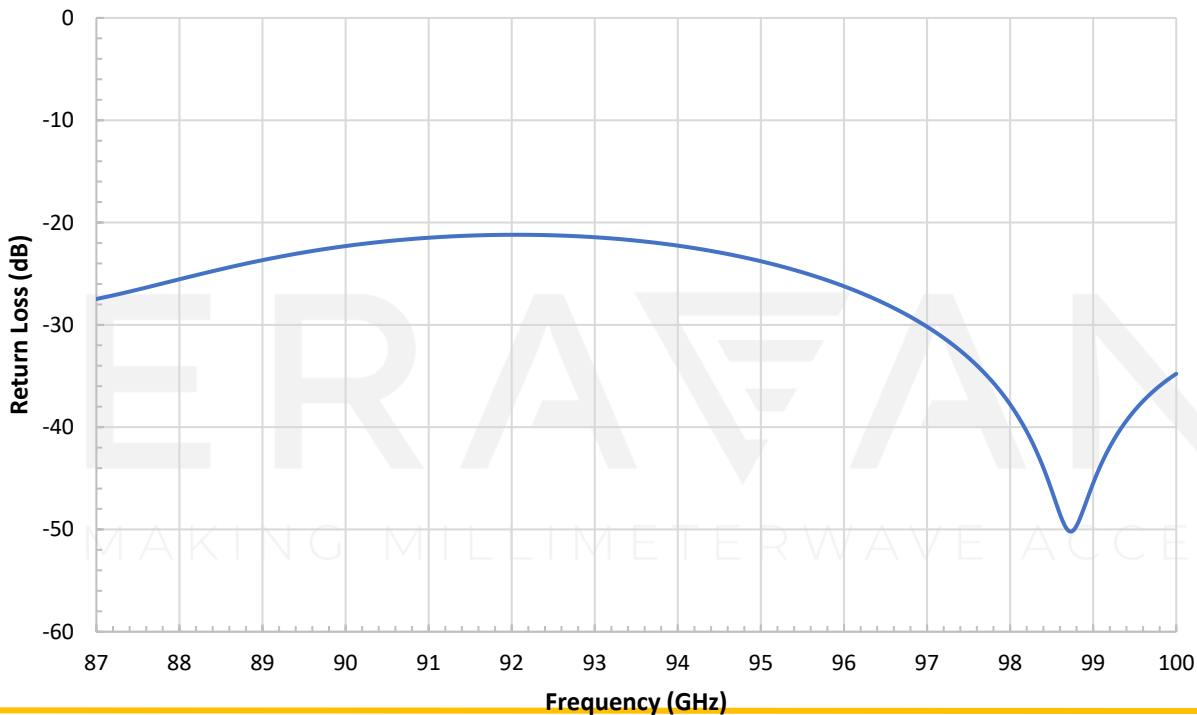

SAC-1533-10-S2

Simulated Gain vs. Frequency

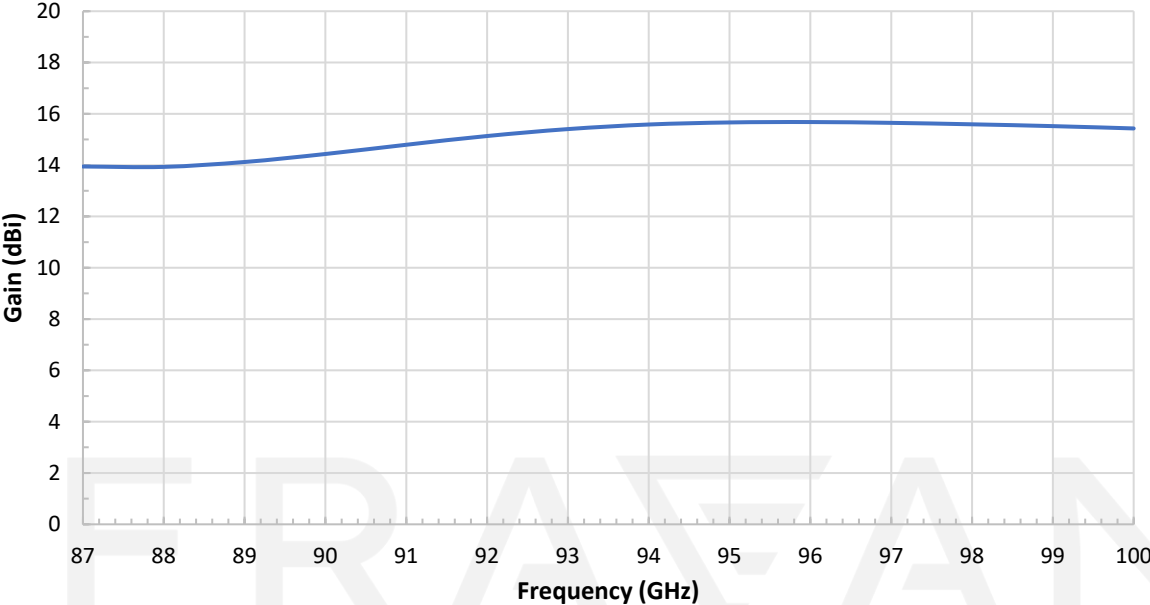

Mechanical Outline: (Unless otherwise specified, all dimensions are in inches [millimeters])

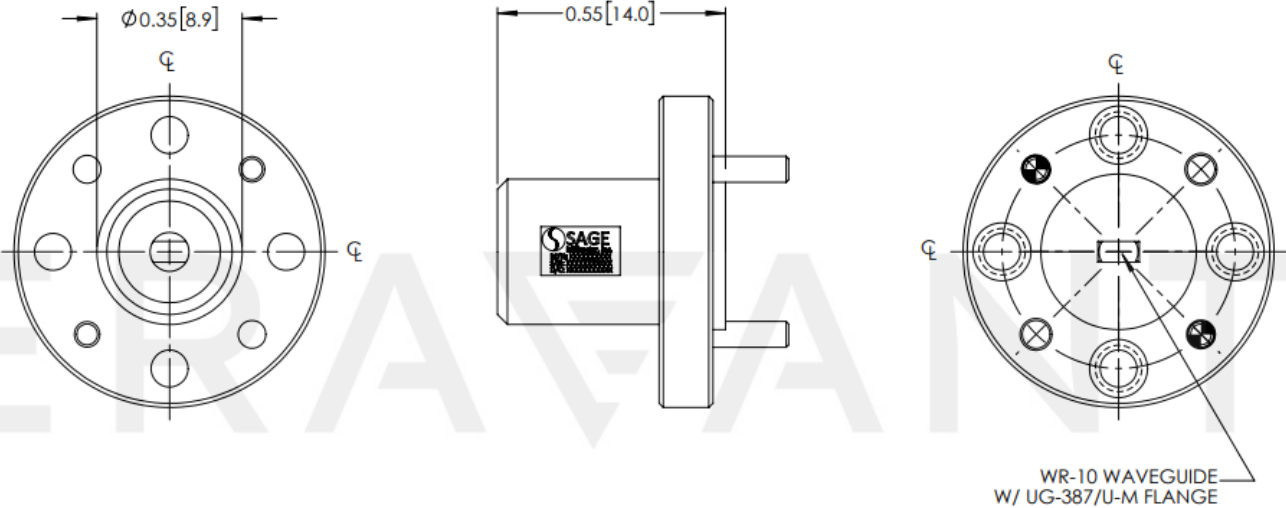

NOTE:

- This antenna is a mature product. The reasons for only providing simulated data can be found in the following [blog here](#).
- Eravant reserves the right to change the information presented without notice.

CAUTION:

- If a waveguide is present, any foreign objects in the waveguide will cause performance degradation and may damage or destroy the unit.
- Any foreign objects in the antenna will cause performance degradation and possible device damage.
- For 1 mm connectors proper torque should be applied: 4.0 ± 0.15 inch-pounds (0.45 ± 0.02 Nm). Torque wrench model [SCH-06004-S1](#) is highly recommended.
- For 1.35 mm, 1.85 mm, 2.4 mm, 2.92 mm, and SMA connectors proper torque should be applied: 8.0 ± 0.15 inch-pounds (0.90 ± 0.02 Nm). Torque wrench model [SCH-08008-S1](#) is highly recommended.

ERAVANT
MAKING MILLIMETERWAVE ACCESSIBLE

ERAVANT
MAKING MILLIMETERWAVE ACCESSIBLE