

SFS-18340315-KFSFSF-N1-M

Broadband Subharmonically Pumped Mixer, 18 to 40 GHz

SFS-18340315-KFSFSF-N1-M is a broadband subharmonically pumped mixer that utilizes a high performance GaAs MMIC to offer superior RF performance. The mixer provides a typical conversion loss of 15 dB over the RF frequency range of 18 to 40 GHz with the IF frequency of 1.0 to 2.0 GHz. The mixer requires an LO signal from 9 to 20 GHz at a nominal +13 dBm pumping level. In addition, the subharmonically pumped mixer offers extreme high LO to IF isolation at 50 dB and RF to LO isolation at 20 dB, respectively. The models with other RF port configurations are offered under various model numbers.



Electrical Specifications:

Parameter	Minimum	Typical	Maximum
RF Frequency	18 GHz		40 GHz
LO Frequency	9 GHz		20 GHz
IF Frequency	1.0 GHz		2.0 GHz
LO Pumping Power		+13 dBm	
Conversion Loss		15 dB	
LO to IF Isolation		50 dB	
RF to LO Isolation		20 dB	
Combined RF & LO Damage Power			+23 dBm
Specification Temperature		+25°C	
Operating Temperature	0°C		+50°C

Mechanical Specifications:

Item	Specification
RF Port	K (F)
LO Port	SMA (F)
IF Port	SMA (F)
Housing Material	Aluminum
Finish	Gold Plated
Weight	0.6 Oz
Size	0.80" (L) x 0.80" (W) x 0.39" (H)
Outline	UH-235-3C

ECCN

EAR99

FEATURES

- Broadband Operation
- High Port Isolations
- LO Frequency at Half of RF Frequency

APPLICATIONS

- Radar Systems
- Communication Systems
- Test Equipment

SUPPLEMENTAL DETAILS



SFS-18340315-KFSFSF-N1-M

Typical Conversion Loss vs. Frequency

LO Power: +13 dBm; IF: 1 GHz

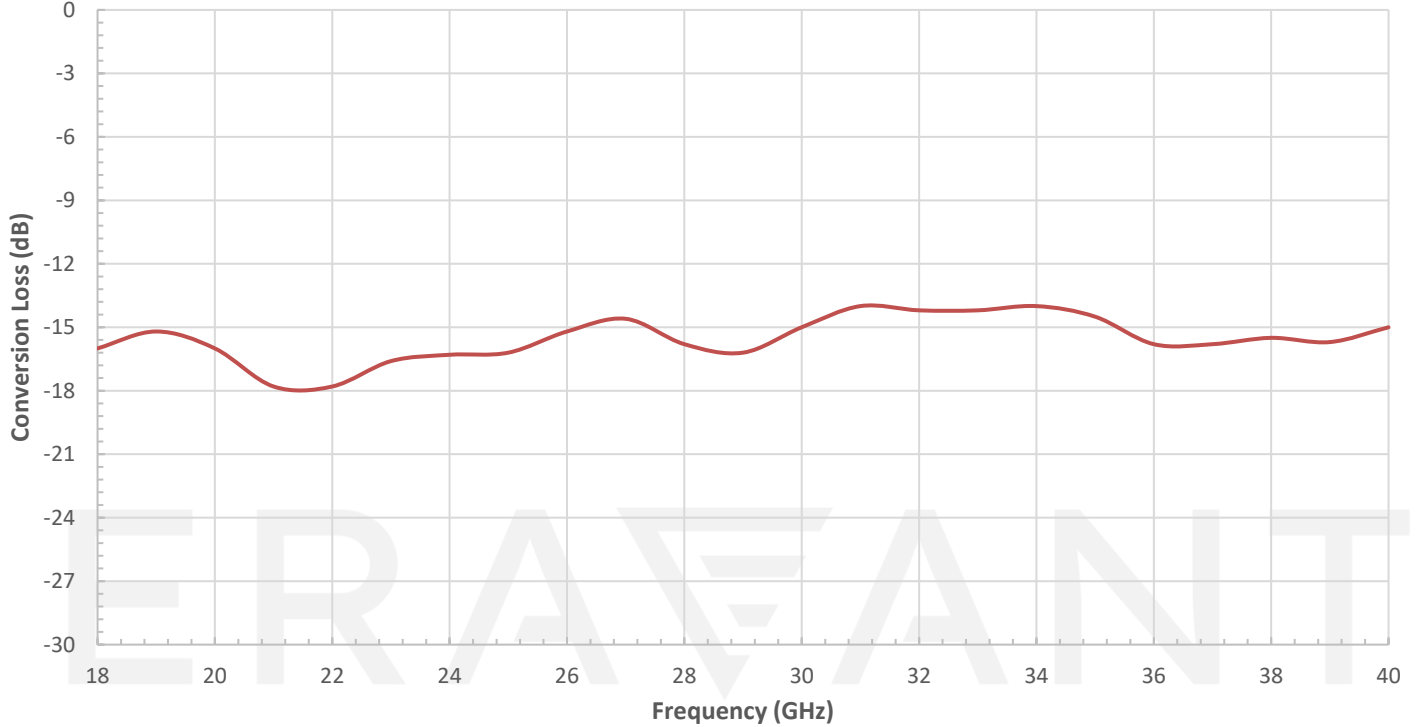

Mechanical Outline: (Unless otherwise specified, all dimensions are in inches [millimeters])

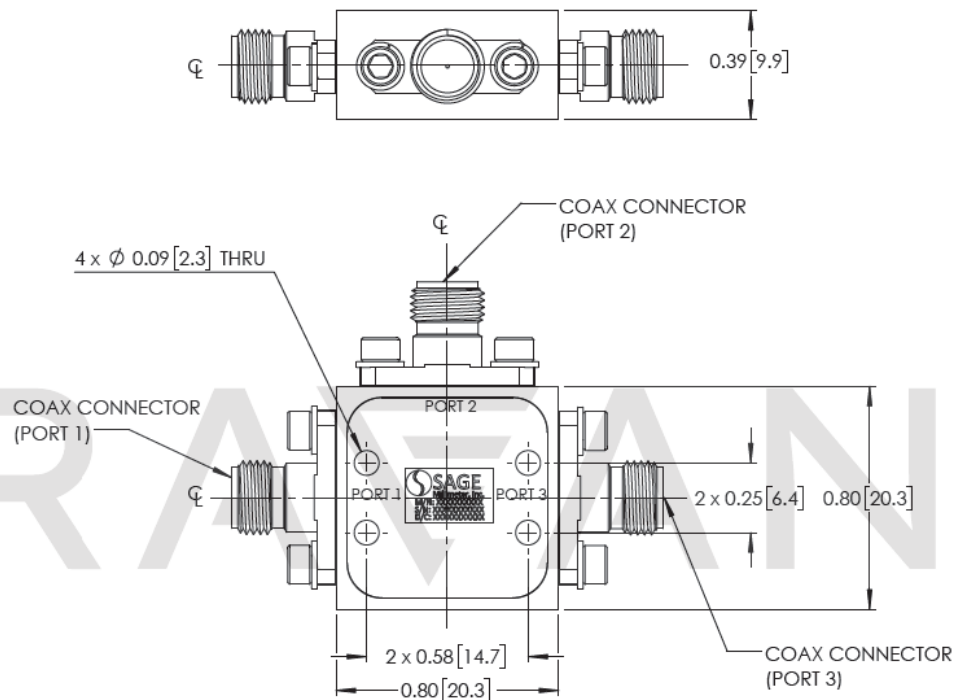

NOTE:

- On condition that test data is provided it is collected from a sample lot. Actual data may vary slightly from unit to unit. All testing is performed under +25 °C room temperature.
- Eravant reserves the right to change the information presented without notice.

CAUTION:

- Exceeding absolute maximum ratings shown will damage the device.
- The device is static sensitive. Always follow ESD rules when working with the device.
- The IF port of the mixer is DC coupled. Use DC block when connect to other device. **Any external bias voltage applied to IF port will damage the mixer.**
- For 1.35 mm, 1.85 mm, 2.4 mm, 2.92 mm, and SMA connectors proper torque should be applied: 8.0 ± 0.15 inch-pounds (0.90 ± 0.02 Nm). Torque wrench model [SCH-08008-S1](#) is highly recommended.

ERAVANT
MAKING MILLIMETERWAVE ACCESSIBLE

ERAVANT
MAKING MILLIMETERWAVE ACCESSIBLE